

The University of Texas at Austin
Dept. of Electrical and Computer Engineering
Midterm #2 *Solutions 3.0*

Prof. Brian L. Evans

Date: December 10, 2018

Course: EE 445S

Name: _____ **Molière** _____
Last, First

- The exam is scheduled to last 50 minutes.
- Open books and open notes. You may refer to your homework assignments and the homework solution sets. You may not share materials with other students.
- Calculators are allowed.
- You may use any standalone computer system, i.e. one that is not connected to a network. **Disable all wireless access from your standalone computer system.**
- Please turn off all smart phones and other personal communication devices.
- Please remove headphones.
- All work should be performed on the quiz itself. If more space is needed, then use the backs of the pages.
- **Fully justify your answers unless instructed otherwise.** When justifying your answers, you may refer to the Johnson, Sethares & Klein (JSK) textbook, the Welch, Wright and Morrow (WWM) lab book, course reader, and course handouts. Please be sure to reference the page/slide number and quote the particular content in your justification.

Problem	Point Value	Your score	Topic
1	30		Bandpass PAM Receiver
2	27		QAM Communication Performance
3	25		Impedance Mismatch
4	18		Symbol Timing Recovery
Total	100		

Problem 2.1. Bandpass Pulse Amplitude Modulation Receiver. 30 points.

A bandpass pulse amplitude modulation (PAM) receiver is described as

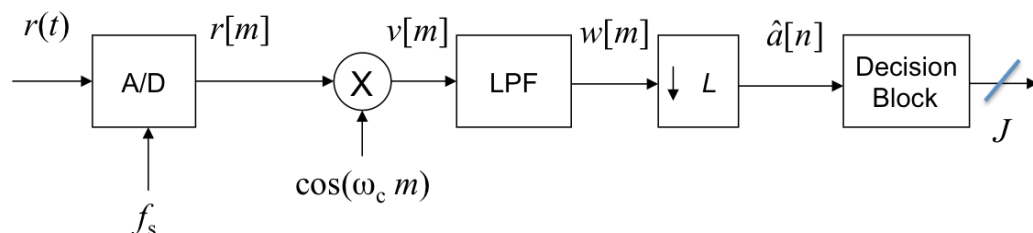

where m is the sampling index and n is the symbol index, and where

- $\hat{a}[n]$ received symbol amplitude
- f_s sampling rate
- f_{sym} symbol rate
- $g[m]$ raised cosine pulse
- J bits/symbol
- L samples/symbol
- M number of levels, i.e. $M = 2^J$
- ω_c carrier frequency in rad/sample

The only impairment being considered is additive thermal noise.

- (a) Give a formula for the bit rate. 3 points.

$J f_{sym}$. Units: [bits/symbol] x [symbols/s] = [bits/s]

- (b) Draw the spectrum of $r(t)$. See sketch on right.

What is the transmission bandwidth? 6 points.

$f_{sym} (1 + \alpha)$ where α is the raised cosine rolloff in $[0, 1]$

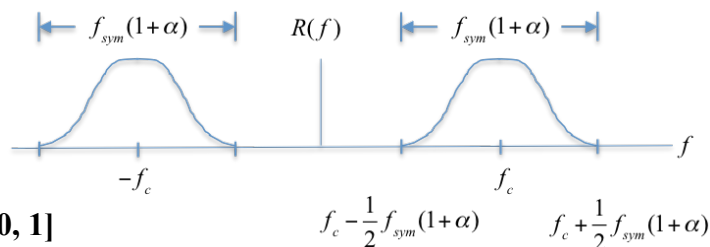

- (c) Give a formula for the minimum sampling rate that would prevent aliasing of the frequencies in the transmitted bandpass PAM signal when processed in the receiver. 3 points.

$f_s > 2 f_{max}$ where $f_{max} = 2 f_c + \frac{1}{2} f_{sym} (1 + \alpha)$ where α is the rolloff factor in $[0, 1]$

- (d) Describe the three roles that the lowpass filter plays. 6 points.

- Demodulating filter to extract the baseband signal
- Anti-aliasing filter for the downsampling by L operation
- Matched filter to filter out-of-band noise

- (e) Give a formula for the optimal choice for the impulse response of the lowpass filter. What measure is being optimized? 6 points.

Impulse response of the optimal matched filter is $k g^* [L - m]$ where k is any non-zero gain.

- (f) Give a fast algorithm for the Decision Block to decode the received M -PAM symbol amplitude $\hat{a}[n]$ into the most likely symbol of bits. Your algorithm should work for any finite M . 6 points.

Transmitted symbol amplitude value $a[n]$ is from the set $\{\dots, -3d, -d, d, 3d, \dots\}$. See below.

Received symbol amplitude $\hat{a}[n] = a[n] + v[n]$ where $v[n]$ is random variable due to noise.

Divide-and-conquer algorithm will eliminate half of possible constellation points each step.

Find first bit: Compare $\hat{a}[n]$ against 0 and negate $\hat{a}[n]$ if negative

Find n th bit: Compare $\hat{a}[n]$ against $2^{J-n} d$ and if true, subtract $2^{J-n} d$ from $\hat{a}[n]$

Use bit pattern as unsigned index into a table of bit patterns corresponding to symbol amplitudes $d, 3d, \dots, 2^{J-1} d, -d, -3d, \dots, -2^{J-1} d$. (Not necessary for constellation map below).

Algorithm takes J comparisons, J subtractions and 1 memory read. $2J$ values are stored.

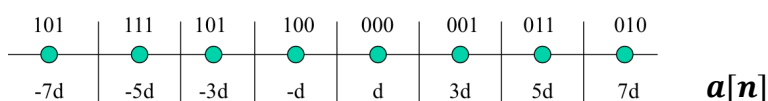

Note: The right constellation below is impractical. It consumes too much power and cannot be Gray coded. For best results in mapping the received symbol amplitude to a symbol of bits, one should find the closest constellation point in Euclidean distance. For rectangular-shaped constellations, such as the left constellation, thresholding would give the same minimum symbol error results as Euclidean distance but would lead to a fast divide-and-conquer algorithm using J comparisons for $M = 2^J$ levels (no multiplications needed).

Lectures 15 & 16
JSK Ch. 16
Lab #6; HW 6.3

Problem 2.2 QAM Communication Performance. 27 points.

Consider the two 16-QAM constellations below. Constellation spacing is $2d$.

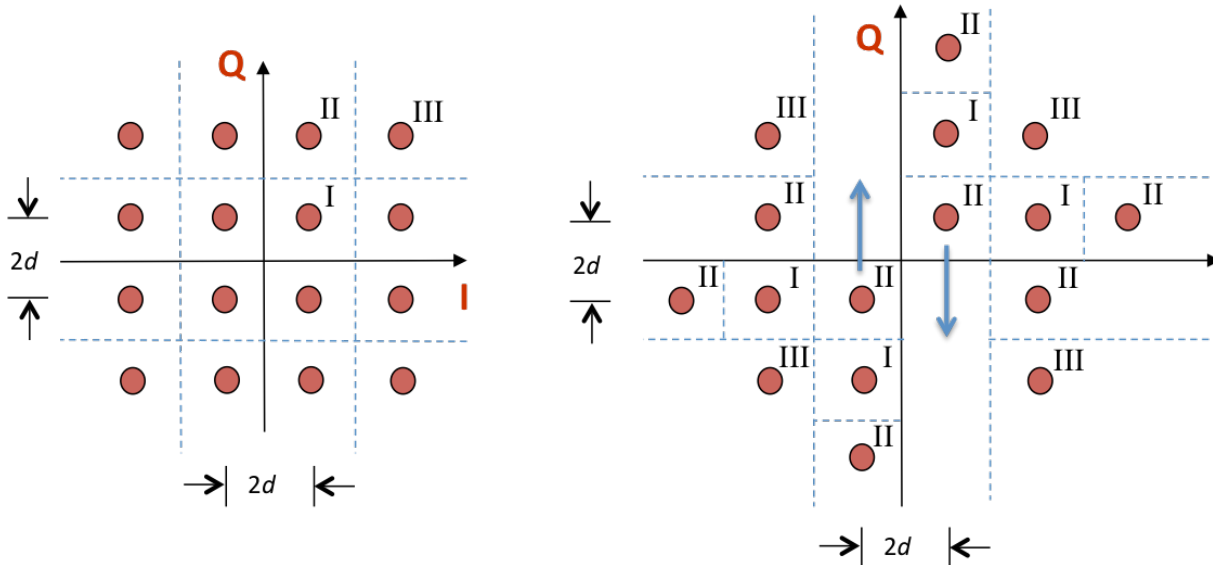

Energy in the pulse shape is 1. Symbol time T_{sym} is 1s. The constellation on the left includes the decision regions with boundaries shown by the in-phase (I) axis, quadrature (Q) axis and dashed lines.

Each part below is worth 3 points. **Please fully justify your answers.**

	Left Constellation	Right Constellation
(a) Peak transmit power	$18d^2$	$26d^2$
(b) Average transmit power	$10d^2$	$15d^2$
(c) Draw the decision regions for the right constellation on top of the right constellation.		
(d) Number of type I regions	4	4
(e) Number of type II regions	8	8
(f) Number of type III regions	4	4
(g) Probability of symbol error for additive Gaussian noise with zero mean & variance σ^2	$3 Q\left(\frac{d}{\sigma}\right) - \frac{9}{4} Q^2\left(\frac{d}{\sigma}\right)$	$3 Q\left(\frac{d}{\sigma}\right) - \frac{9}{4} Q^2\left(\frac{d}{\sigma}\right)$
(h) Express d/σ as a function of the Signal-to-Noise Ratio (SNR)	$\text{SNR} = \frac{10d^2}{\sigma^2}$ $\frac{d}{\sigma} = \sqrt{\frac{\text{SNR}}{10}}$	$\text{SNR} = \frac{15d^2}{\sigma^2}$ $\frac{d}{\sigma} = \sqrt{\frac{\text{SNR}}{15}}$

(i) In simulation, we can test the communication performance for different SNR settings by changing the variance of the additive Gaussian noise model. How would you use different SNR settings in a field test where the amount of noise power is not under our control? 3 points.

Received SNR = Average Transmit Signal Power / Average Noise Power

Answer #1: Adjust d to adjust the average transmit signal power.

Answer #2: Add noise at the receiver.

Problem 2.3. Impedance Mismatch. 25 points.

After a system starts up and begins to operate, the temperature inside the system will increase. Power management inside the system can also cause significant changes in the temperature of the system.

These temperature changes cause changes in the resistance, capacitance, and inductance in the system, which can in turn causes changes to the impedance mismatch to any wired connections to the system.

Impedance mismatch can be compensated by means of an adaptive finite impulse response (FIR) filter $h[m]$ that predistorts the signal $x[m]$ prior to digital-to-analog (D/A) conversion.

D/A and analog-to-digital (A/D) converters are synchronized via a common sampling clock.

Let N_h = Number of coefficients in $h[m]$

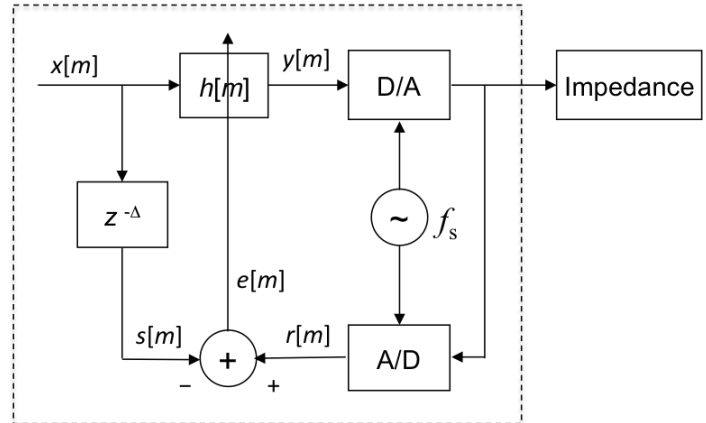

- (a) How could you determine a fixed value of Δ without the need for training? 6 points.

The delay Δ represents the delay through the adaptive filter, the D/A converter (1 sample) and the A/D converter (1 sample). The adaptive filter won't have symmetry in its impulse response about the midpoint; i.e., the group delay won't be a constant. The worst-case delay is $N_h - 1$ samples. So, $\Delta = (N_h - 1) + 2 = N_h + 1$.

- (b) Give an objective function $J(e[m])$. 3 points.

We would like to minimize the error between $r[m]$ and $s[m]$:

$$J(e[m]) = \frac{1}{2} e^2[m]$$

- (c) Give the update equation for the vector \vec{h} of FIR coefficients. 12 points.

$$\vec{h}[m+1] = \vec{h}[m] - \mu \left. \frac{dJ(e[m])}{d\vec{h}} \right|_{\vec{h}=\vec{h}[m]}$$

$$e[m] = r[m] - s[m] \text{ and } s[m] = x[m - \Delta]$$

Since $s[m]$ does not have any dependence on \vec{h} ,

$$\frac{dJ(e[m])}{d\vec{h}} = e[m] \frac{de[m]}{d\vec{h}} = e[m] \frac{dr[m]}{d\vec{h}}$$

Please see the next page for several ways to complete the derivation.

- (d) What range of values would you recommend for the step size μ ? Why? 4 points.

For convergence, use small positive values for μ , e.g. 0.01 or 0.001, should be used.

When μ is zero, the update equation would not be able to update.

When μ is either negative or a large positive number, the update will diverge.

Solution #1 for (c): Assume there is no impedance mismatch. In this case, $y[m]$ experiences a one sample delay through the D/A converter and a one sample delay through the A/D converter:

$$r[m] = y[m - 2]$$

$$y[m] = h_0 x[m] + h_1 x[m - 1] + h_2 x[m - 2] + \dots + h_{N_h-1} x[m - (N_h - 1)]$$

$$\frac{dJ(e[m])}{d\vec{h}} = e[m] \frac{dr[m]}{d\vec{h}} = e[m] \frac{dy[m-2]}{d\vec{h}} = e[m] \vec{x}[m-2]$$

$$\text{where } \vec{x}[m-2] = [x[m-2] \quad x[m-3] \quad x[m-4] \quad \dots \quad x[m-N_h-1]]$$

Initial guess for the filter coefficients: $\vec{h} = [0 \ 0 \ \dots \ 0 \ 1]$ to match $\Delta = (N_h - 1) + 2 = N_h + 1$.

Solution #2 for (c): Model a finite number of reflections between A/D converter output and impedance by using an FIR filter $v(t)$. We'll use a discrete-time version of the FIR filter:

$$r[m] = v[m] * y[m] = v[m] * x[m] * h[m] = (v[m] * x[m]) * h[m]$$

We know $x[m]$. Let's assume that we know $v[m]$ for now.

Define $w[m] = v[m] * x[m]$ and hence $r[m] = w[m] * h[m]$:

$$r[m] = h_0 w[m] + h_1 w[m - 1] + \dots + h_{N_v-1} w[m - (N_v - 1)]$$

$$\frac{dJ(e[m])}{d\vec{h}} = e[m] \frac{dr[m]}{d\vec{h}} = e[m] \vec{w}[m]$$

$$\text{where } \vec{w}[m] = [w[m] \quad w[m-1] \quad \dots \quad w[m - (N_h - 1)]]$$

We can solve for $v[m]$ as a least-squares filter or an adaptive filter.

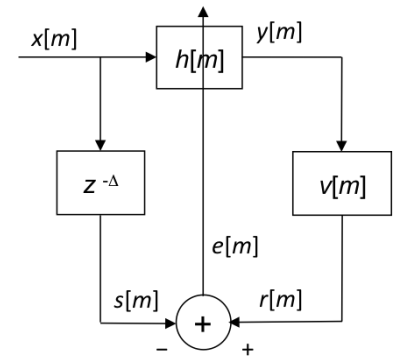

Solution #2 Algorithm

$\vec{v} = [0 \ 0 \ 1 \ 0 \ \dots \ 0 \ 0]$ which has N_v elements and $\bar{\mu} = 0.01$

Adapt $v[m]$ to learn reflections without pre-distortion filter enabled

$$y[m] = x[m]$$

$$q[m] = v_0 y[m] + v_1 y[m - 1] + \dots + v_{N_v-1} y[m - (N_v - 1)]$$

$$d[m] = r[m] - q[m]$$

$$\vec{y}[m] = [y[m] \quad y[m-1] \quad \dots \quad y[m - (N_v - 1)]]$$

$$\vec{v}[m+1] = \vec{v}[m] - \bar{\mu} d[m] \vec{y}[m]$$

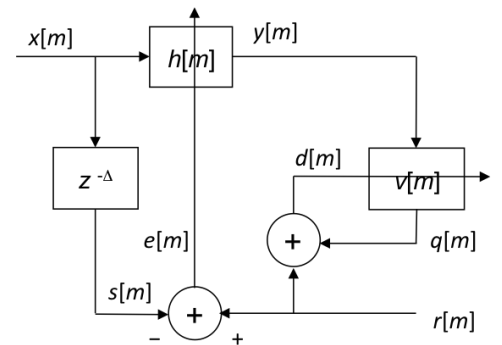

$\Delta = N_v - 1$ and $\mu = 0.01$ and $\vec{h} = [1 \ 0 \ 0 \ 0 \ \dots \ 0 \ 0]$ which has N_h elements

Adapt both the pre-distortion filter and the reflection model

$$y[m] = h_0 x[m] + h_1 x[m - 1] + h_2 x[m - 2] + \dots + h_{N_h-1} x[m - (N_h - 1)]$$

$$\vec{w}[m] = [w[m] \quad w[m-1] \quad w[m-2] \quad \dots \quad w[m - (N_h - 1)]] \text{ and } w[m] = v[m] * x[m]$$

$$e[m] = r[m] - s[m] \text{ and } s[m] = x[m - \Delta]$$

$$\vec{h}[m+1] = \vec{h}[m] - \mu \frac{dJ(e[m])}{d\vec{h}} \Big|_{\vec{h}=\vec{h}[m]} = \vec{h}[m] - \mu e[m] \vec{w}[m]$$

$$q[m] = v_0 y[m] + v_1 y[m - 1] + v_2 y[m - 2] + \dots + v_{N_v-1} y[m - (N_v - 1)]$$

$$d[m] = r[m] - q[m]$$

$$\vec{y}[m] = [y[m] \quad y[m-1] \quad \dots \quad y[m - (N_v - 1)]]$$

$$\vec{v}[m+1] = \vec{v}[m] - \bar{\mu} d[m] \vec{y}[m]$$

Problem 2.4. Symbol Timing Recovery. 18 points

We add symbol timing recovery and correction to the bandpass pulse amplitude modulation (PAM) receiver in Problem 2.1:

Slide 16-10
Reader Appendix M
JSK Ch. 12
Lab #5
HW 6.2

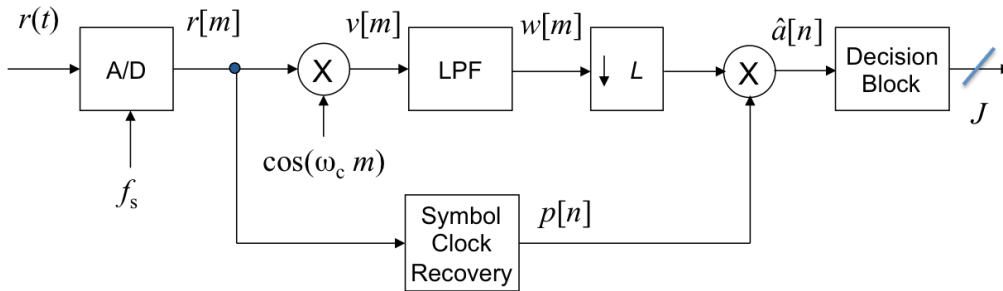

where m is the sampling index and n is the symbol index, and where

- $\hat{a}[n]$ received symbol amplitude
- $g[m]$ raised cosine pulse shape
- M number of levels, i.e. $M = 2^J$
- f_s sampling rate
- J bits/symbol
- ω_c carrier frequency in rad/sample
- f_{sym} symbol rate
- L samples/symbol

The block diagram of the symbol timing recovery and correction subsystem follows:

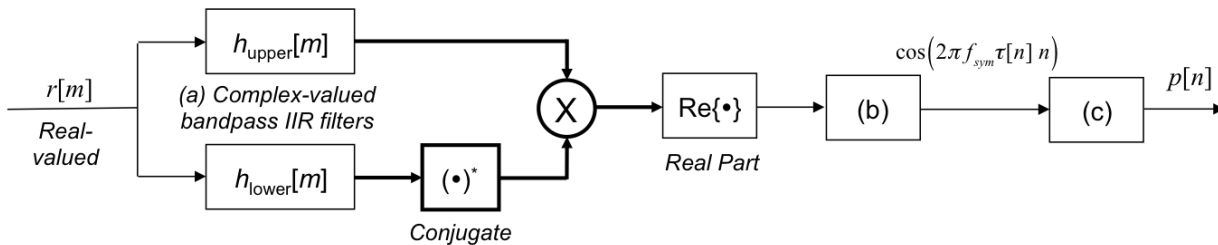

Upper filter $h_{upper}[m]$ locks onto (passes) continuous-time frequency $f_c + \frac{1}{2}f_{sym}$ and the lower filter $h_{lower}[m]$ locks onto (passes) $f_c - \frac{1}{2}f_{sym}$. **The thicker/bold lines indicate complex-valued signals.**

The sample timing offset is τ_s , which accumulates over L samples to give the symbol timing offset τ .

(a) Design a first-order complex-valued infinite impulse response (IIR) filter for $h_{upper}[m]$. 6 points.

Center frequency: $\omega_{upper} = 2\pi \frac{f_c + \frac{1}{2}f_{sym}}{f_s}$

Normally, we would use a pole at radius close to one.

For this case, we'll place the pole on the unit circle.

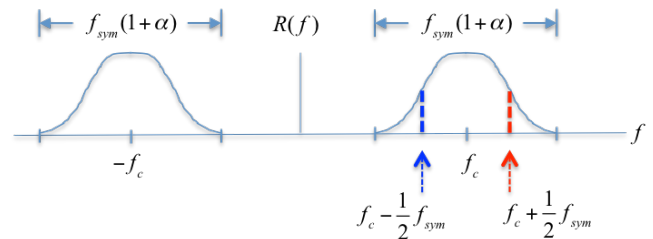

(b) Design this block to convert from the sampling rate to the symbol rate. 6 points.

Downsampler by L.

(c) Design a filter to smooth the rotation signal $\cos(2\pi f_{sym} \tau[n] n)$. 6 points.

Let $x[n] = \cos(2\pi f_{sym} \tau[n] n)$.

Use a first-order lowpass IIR filter

$p[n] = c p[n - 1] + (1 - c) x[n]$

where the pole location $c = 0.9$.

When $m = L$, output is $\exp(j 2\pi f_{sym} \tau)$:

