

Introduction

You have successfully built a DC-AC inverter. You will now use your inverter to convert DC to AC and send power back into the AC grid. Your grid access point is a 120V wall outlet. **Make sure that your inverter is working properly before beginning this experiment.**

To begin with, you will use a 100Vdc bus created by a variac + isolation transformer + special DBR that is rated for that voltage. **So be careful!** Later, if there is good sun, you can use one of our 40V (open circuit) solar panel pairs and feed its DC power into the grid.

Steady-State AC Equivalent Circuit of the H-bridge Inverter

Consider the H-bridge inverter circuit illustrated below. We have observed in the H-bridge experiment that when V_{cont} is steady-state AC, and MOSFET firing is controlled using unipolar PWM, and inverter output is properly filtered, then the equivalent circuit “seen” by the load (e.g., motor) has a dominant sinusoidal component.

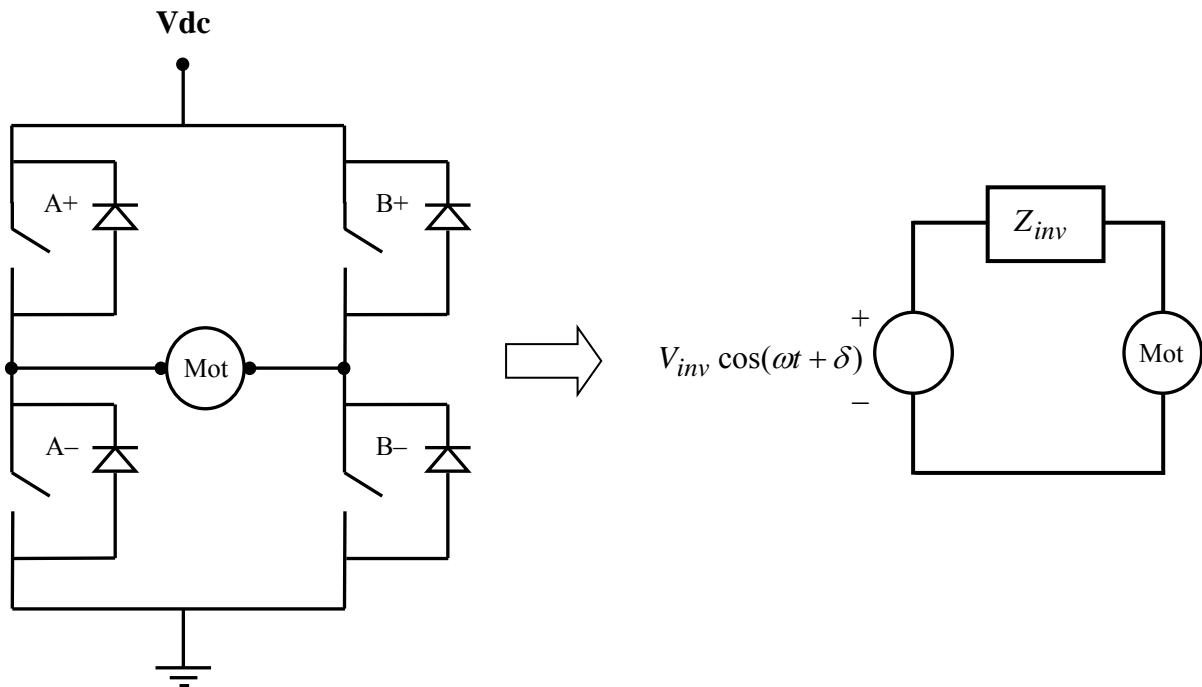

In the above figure, $V_{inv} = \frac{V_{dc}}{\sqrt{2}} \cdot m_a$ rms volts, and Z_{inv} is the impedance of the inverter at the AC operating frequency. Unless a very large inductor is intentionally added to the inverter output, Z_{inv} is mostly resistive in low voltage (i.e., less than 1kV) circuits.

Re-examination of the H-Bridge Circuit

The H-bridge is not limited to inverter operation. For example, without changing circuit topology, move the motor to the left, outside the bridge, as shown on the next page.

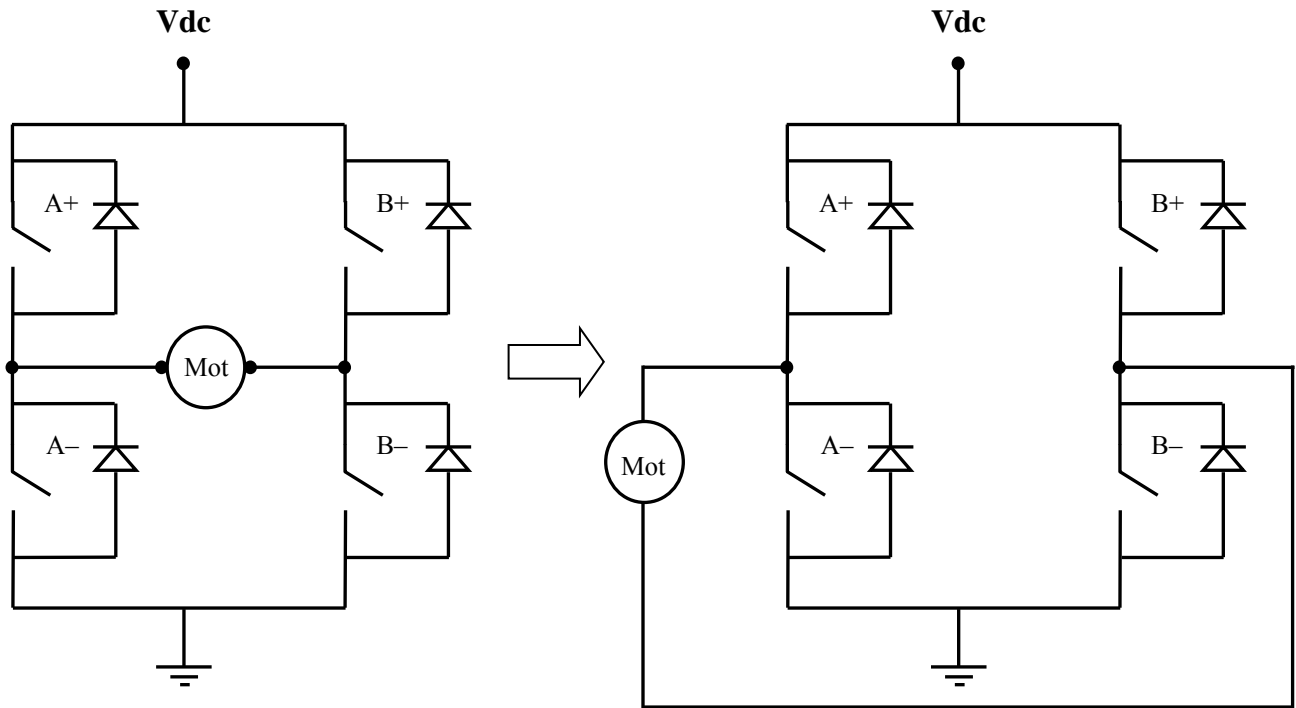

Now, move the DC terminals to the right, and replace Vdc with a capacitor. Then, replace the motor with an AC source.

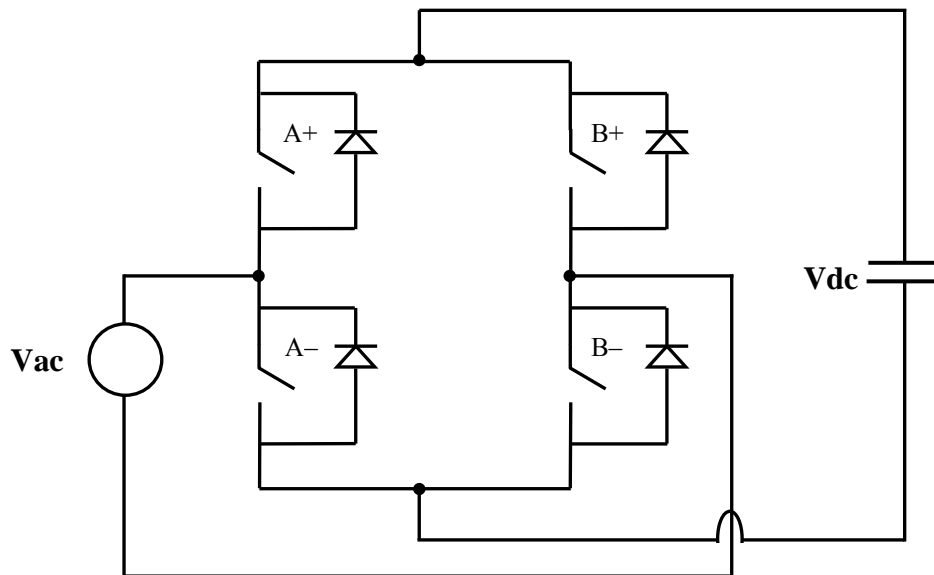

You can see that if the MOSFETs are never switched “on,” the above circuit behaves like a DBR circuit because of the internal diodes of the MOSFETs! Thus, it is clear that the H-bridge circuit can also be a rectifier (like the DBR), where power moves from the AC side to the DC side. Thus, by controlling the firing of the MOSFETs, the H-bridge can be either a rectifier or an inverter.

Control of Power Flow into the Grid

Consider the AC equivalent, but replace the motor with the grid (i.e., a wall outlet, either hard-wired or scaled down using a variac). The grid has some impedance, but it is much smaller than the inverter impedance.

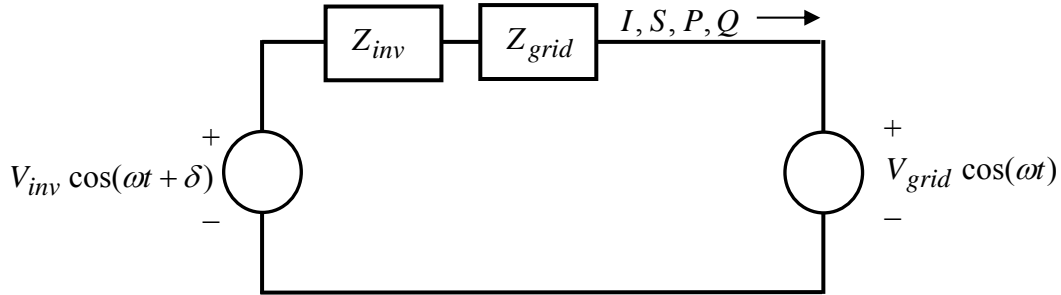

The phasor current that flows is

$$I = \frac{V_{inv} \angle \delta - V_{grid} \angle 0}{Z_{inv} + Z_{grid}},$$

and the complex power, active power, and reactive power flowing into the grid are

$$S = V_{grid} I^*, \quad P = \text{real}(S), \quad Q = \text{imaginary}(S).$$

Define

$$Z_{tot} = Z_{inv} + Z_{grid}, \quad \text{where } Z_{tot} = R_{tot} + jX_{tot}.$$

Then

$$S = V_{grid} \angle 0 \cdot \left(\frac{V_{inv} \angle \delta - V_{grid} \angle 0}{Z_{tot}} \right)^* = \frac{(V_{grid} V_{inv} \angle -\delta) - (V_{grid}^2)}{R_{tot} - jX_{tot}}.$$

Expanding yields

$$S = \frac{V_{grid} V_{inv} (\cos(-\delta) + j \sin(-\delta)) - V_{grid}^2}{R_{tot} - jX_{tot}} = \frac{V_{grid} V_{inv} (\cos \delta - j \sin \delta) - V_{grid}^2}{R_{tot} - jX_{tot}}. \quad (1)$$

The Resistive Impedance Case (typical for circuits below 1kV)

Now, consider the usual low-voltage situation where $R_{tot} \gg X_{tot}$. Then

$$S = \frac{V_{grid}V_{inv}(\cos \delta - j \sin \delta) - V_{grid}^2}{R_{tot}} = \frac{V_{grid}V_{inv} \cos \delta - V_{grid}^2 - jV_{grid}V_{inv} \sin \delta}{R_{tot}}$$

$$= \frac{V_{grid}}{R_{tot}} (V_{inv} \cos \delta - V_{grid}) - j \frac{V_{grid}V_{inv}}{R_{tot}} \sin \delta .$$

Thus, when X_{tot} is neglected,

$$\text{Resistive impedance case: } P = \frac{V_{grid}}{R_{tot}} (V_{inv} \cos \delta - V_{grid}), \quad (2)$$

$$\text{Resistive impedance case: } Q = -j \frac{V_{grid}V_{inv}}{R_{tot}} \sin \delta . \quad (3)$$

Thus, when X_{tot} is neglected, then P is proportional to $(V_{inv} \cos \delta - V_{grid})$. Clearly V_{inv} must be greater than V_{grid} for inverter action to occur. In our lab experiment, angle δ is zero because the inverter control signal is a replica of V_{grid} . **Thus, for the resistive case in our experiment, $(V_{inv} - V_{grid})$ controls P, and Q is zero.**

The Inductive Impedance Case (typical for circuits higher than several kV)

Now, consider the alternate case, i.e., $X_{tot} \gg R_{tot}$, as might occur if a large series inductor is inserted in the power path. Re-evaluating (1) yields

$$S = \frac{V_{grid}V_{inv}}{X_{tot}} \sin \delta + j \frac{V_{grid}}{X_{tot}} (V_{inv} \cos \delta - V_{grid}).$$

Thus, when R_{tot} is neglected,

$$\text{Inductive impedance case: } P = \frac{V_{grid}V_{inv}}{X_{tot}} \sin \delta , \quad (4)$$

$$\text{Inductive impedance case: } Q = \frac{V_{grid}}{X_{tot}} (V_{inv} \cos \delta - V_{grid}). \quad (5)$$

Thus, for the inductive case, angle δ controls P, and V_{inv} controls Q.

The Experiment

Make sure that your inverter is working properly before beginning this experiment. Be considerate of others who are waiting.

To send power back to the grid, it is essential that V_{cont} be a scaled-down version of the AC grid voltage so that there is no phase shift or frequency error introduced. In a commercial building, such as ENS, wall outlets are distributed among the three phases (i.e., a-b-c) to balance the load. The three phases have 120° phase spacing. **To avoid a 120° error in phase shift, it is important that you plug your AC wall wart into the same lab bench to which you will send power.** That way, you can be assured that your control voltage and output voltage are on the same a-b-c phase.

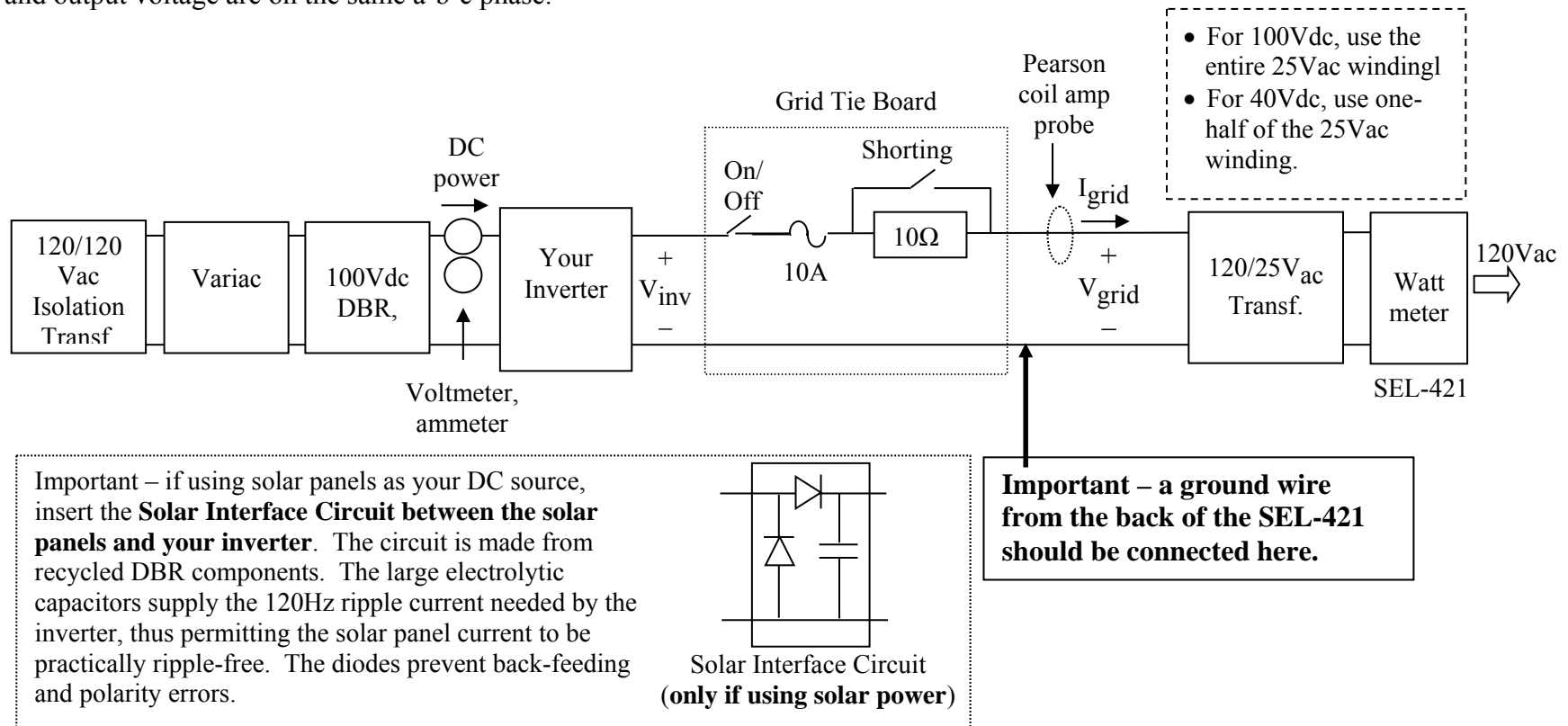

EE462L, Power Electronics, Powering the Grid with Renewable Energy

Version April 1, 2014

1. Make sure the two knife switches on the Grid Tie Board are open.
2. Make sure that the variac is off and turned all the way down.
3. Make sure that the ground wire from the SEL-421 is connected to the point shown in the previous figure.
4. Connect a 12Vdc wall wart to your inverter jack, and the yellow-painted AC wall wart (with audio plug) to Vcont.
5. Connect the input DBR to your inverter, and slowly bring up the variac so that Vdc is about 40V. Idc should remain zero for now.
6. View Vinv and Vgrid on a scope. **They should be in phase.** If 180 degrees out of phase, reverse the yellow-painted AC wall wart.
7. Adjust ma until about 1.0.
8. Check the rms voltage of Vinv and Vgrid with a multimeter. Adjust Vdc until Vinv is within 2 volts of Vgrid.
9. The two voltage waveforms should now have approximately the same magnitude on the scope.
10. The Shorting knife-switch stays OPEN for now. Close the On/Off knife-switch on the Grid Tie Board, which connects the inverter to the grid through the 10ohm power resistor.
11. If no sparks, buzzing, or Idc, close the shorting knife-switch. Bring up the variac so that about 3A of dc current flows. This should occur at about 70Vdc, which means that your inverter is receiving about 200W of DC power
12. View the power flow on the SEL421. The reading will be negative, which means that power is flowing back into the wall outlet. If the SEL is not properly set up to read power, then do the following:
 - A. Press ENT to reach the "Main Menu," then
 - B. Press ENT to reach the "Meter Menu," then
 - C. Press the down arrow to reach the "Fundamental Meter" selection, then
 - D. Press ENT to reach the "Meter Sub Menu," then
 - E. Press ENT to reach the "Fundamental Line Meter" to observe volts and amps, then
 - F. Press the down arrow three times to view P.Pressing ENT several times will take you back to the "Rotating Display"
13. View the Pearson Coil waveform. Expect something like this. It is actually very "clean" for an inverter (about 20% THDI)

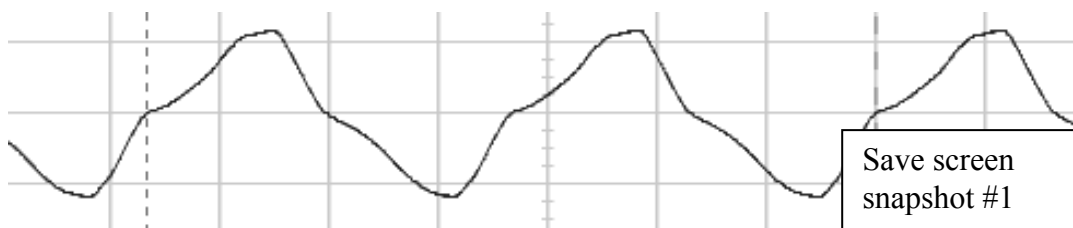

14. Open the Shorting knife-switch, and then the On/Off knife-switch
15. Turn down the variac, and then switch off the variac.

If you want to send solar power to the grid, use the solar interface circuit and one-half of the 25Vac transformer winding.