

EE462L, Power Electronics, Capacitor Filtered Diode Bridge Rectifier

Version January 25, 2014

Overview

Electronic loads, such as desktop computers and televisions, operate on dc rather than ac power. However, utility power is largely distributed in the U.S. through a 60 Hz ac system. Electronic loads often employ a capacitor filtered, diode bridge rectifier that converts the incoming ac voltage to dc. Later, we will learn how to efficiently reduce rectifier output voltage levels to more commonly used values such as 12 Vdc.

(Note: “Rectifier” implies ac \rightarrow dc conversion. “Inverter” implies dc \rightarrow ac conversion which is more complicated. But, we will build this circuit too, later on this semester!)

This is a two-week team project, and the rectifier circuit that you and your partner build will be used many times during this semester. Combined with the nominal 25 V ac transformer source, it will produce approximately the same 36-40 V dc output value that the solar panel pairs on the ENS roof produce. **So, please build a neat, rugged circuit that will last, and solder your connections properly!** When finished, neatly print your team member names on the wood with a dark pen or permanent marker **for all to see clearly.**

Important

Do not energize your circuit until it has been inspected by the Professor or one of the TAs. Carefully check the polarity of the diode bridge and capacitor – **electrolytic capacitors can explode if they are reverse biased.** You will connect 28 Vac (unloaded output of 25 V transformer) to the input of your DBR.

Basics of Circuit Operation

The basic components of a single-phase diode bridge rectifier are four diodes and a large electrolytic capacitor. The four diodes are often packaged together as a single four-terminal device. The diodes rectify the incoming ac voltage, the capacitor smooths the peak-to-peak ripple voltage in the dc voltage output to a reasonable value (e.g. 5-10% of peak V_{dc}).

The basic rectifier circuit is shown below in Figure 1. When V_{ac} is positive, diodes 1 and 2 conduct, while diodes 3 and 4 are reverse biased and thus can be treated as open circuits. When V_{ac} is negative, diodes 3 and 4 conduct, while diodes 1 and 2 are reverse biased and thus can be treated as open circuits.

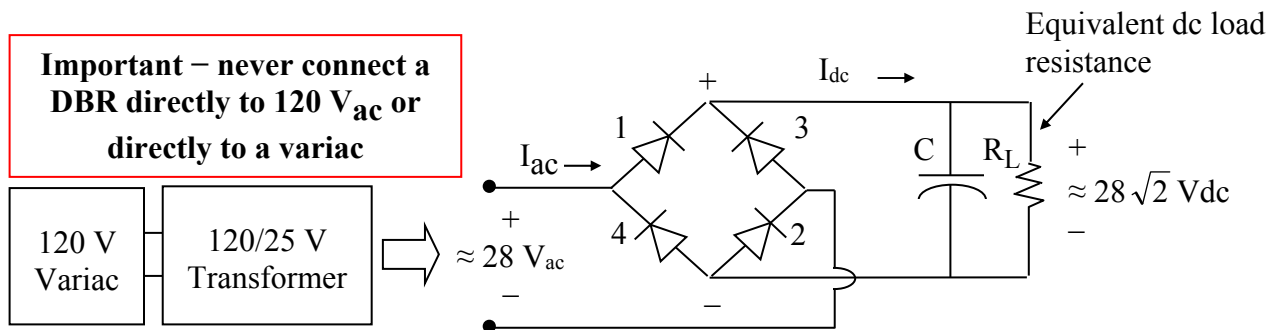

Figure 1. Single-Phase Diode Bridge with Capacitor Filter

EE462L, Power Electronics, Capacitor Filtered Diode Bridge Rectifier

Version January 25, 2014

Important note on safety: There are two hazards if you connect a variac directly to a DBR. First, and most important, is because when using a variac it is very easy to accidentally apply more than 35 V_{ac} to the DBR, which when rectified exceeds the 50 V rating of the capacitor. If you accidentally apply 120 V_{ac} , then the capacitor voltage can reach 165 V! The capacitor can rupture or explode when severely overvoltaged, and the circuit breaker inside the variac may not prevent this from happening. Never touch the residue from a leaking capacitor with your bare hands.

Second, the variac (an autotransformer) does not isolate the power ground from the load. Thus, when you touch the variac "hot" output, you can get a shock. But if you use a dual-winding transformer, like the 120/25 transformers in the lab, the output has no ground reference. With no ground reference, you can still get shocked, but you must contact both terminals of the transformer output for this to happen.

To better understand the operation of the circuit, imagine that the capacitor is removed. Diodes 1 and 2 conduct when $V_{ac} > 0$. Diodes 3 and 4 conduct when $V_{ac} < 0$. The resulting voltage waveforms with $V_{ac} = 28$ V are shown in Figure 2.

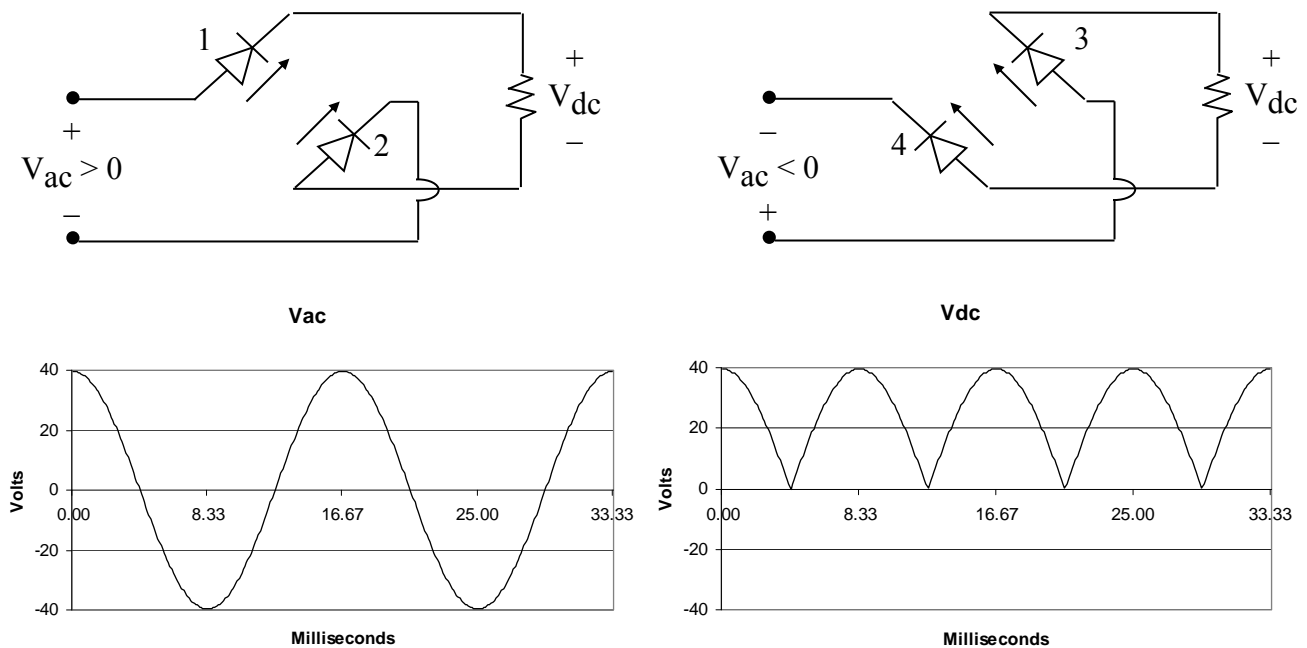

Figure 2. AC and DC Voltage Waveforms with a DC Load Resistor and No Capacitor

EE462L, Power Electronics, Capacitor Filtered Diode Bridge Rectifier

Version January 25, 2014

The addition of capacitor C smooths the dc voltage waveform. If time constant $R_L C$ significantly exceeds $\frac{T}{2}$, where $T = \frac{1}{f}$, then the capacitor provides load power when the rectified AC voltage falls below the capacitor voltage. As simulated by Excel program EE462L_Diode_Bridge_Rectifier.xls for the case shown below,

F [Hz]	C [μ F]	Vac [V]	P [W]
60	18000	28	200

the waveform for V_{dc} takes the form of V_{cap} in Figure 3.

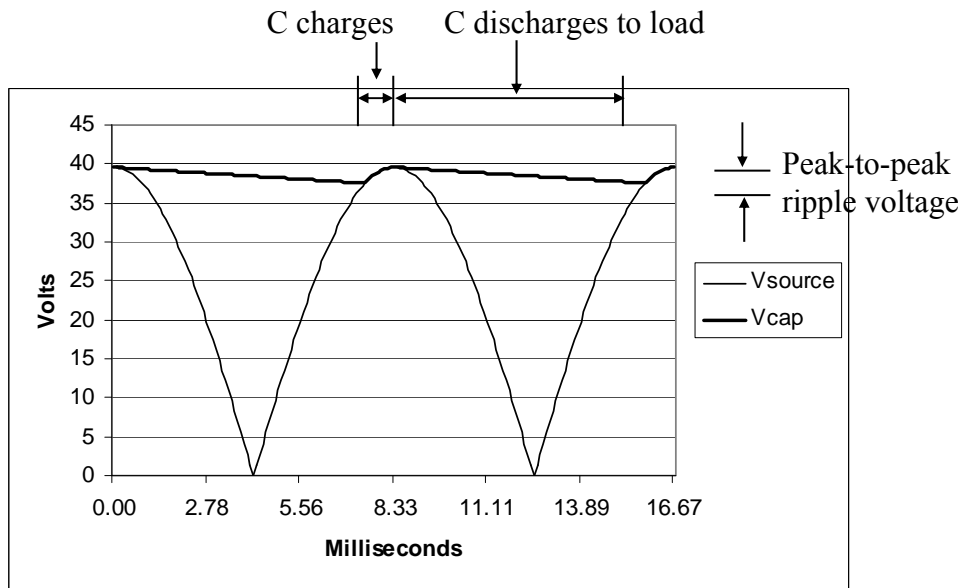

Figure 3. Impact of C on Load Voltage

As the load power increases, the capacitor discharges faster, the peak-to-peak ripple voltage increases, and the average dc voltage (i.e., the average value of the V_{cap} curve in Figure 3) falls. For zero load, V_{cap} remains equal to the peak of the rectified source voltage, and the ripple voltage is therefore zero.

Current and power flow from the ac side only when C is charging. When not charging, the voltage across C is greater than the rectified source voltage, and the diodes prevent current from flowing back into the ac side. Thus, ac current and power flow into the circuit in relatively short “bursts.” As load power increases, the width of the current bursts becomes wider and taller, as illustrated in Figure 4. The precise shape of the current pulse depends on system impedance. If the impedance is mainly resistive, the current pulses resemble the top portions of sine waves. Inductance in the system impedance causes a skewing to the right.

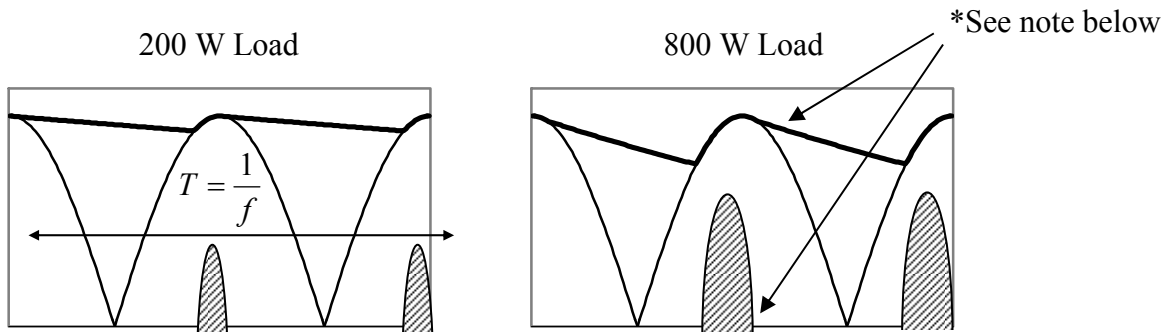

Figure 4. DC-Side Current i_{dc} for Two Different Load Levels
(This figure shows how the average voltage to the load drops as load power increases.
This phenomenon is due to the capacitor action and is not due to DBR resistance.)

* Inductance in the power system and transformer will cause the current to flow after the peak of the voltage curve. In that case, the capacitor voltage will follow the rectified voltage wave for some time after the peak. The higher the power level, the longer the current flows.

Reflected to the ac-side, the current is alternating with zero average value and half-wave symmetry, as shown below in Figure 5 for the 200 W example.

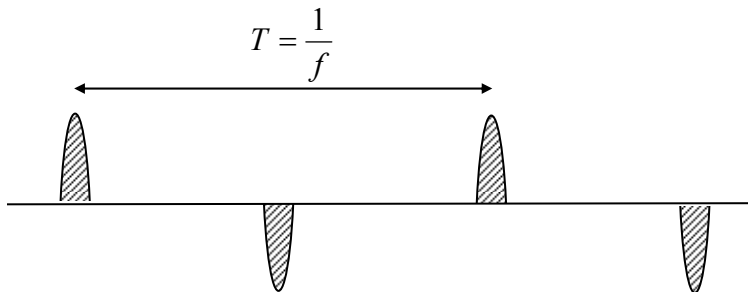

Figure 5. AC-Side Current, I_{ac}

Estimation of DC Ripple Voltage for Constant Power Loads

Most power electronic loads require constant power. Thus, representing the load as a fixed resistor, as shown in Figure 1, is not exactly correct.

For constant-power cases, peak-to-peak voltage ripple can be computed using energy balance in the capacitor as follows. If the “C discharging” period in Figure 3 is Δt , where $\frac{T}{4} \leq \Delta t \leq \frac{T}{2}$, then the energy provided by C during Δt is

$$\frac{1}{2} C (V_{peak}^2 - V_{min}^2) = P \Delta t, \quad (1)$$

where V_{peak} and V_{min} are the peak and minimum capacitor voltages in Figure 3, and P is the DC load power (approx. constant). From (1),

$$V_{peak}^2 - V_{min}^2 = \frac{2P\Delta t}{C} .$$

Factoring the quadratic yields

$$(V_{peak} - V_{min})(V_{peak} + V_{min}) = \frac{2P\Delta t}{C} , \text{ or.}$$

$$(V_{peak} - V_{min}) = \frac{2P\Delta t}{C(V_{peak} + V_{min})} . \quad (2)$$

At this point, a helpful simplification can be made if, as shown in Figure 6, the following assumptions are made: 1. the AC sine wave of voltage is approximated as a triangular wave, and 2. a straight line decay of voltage.

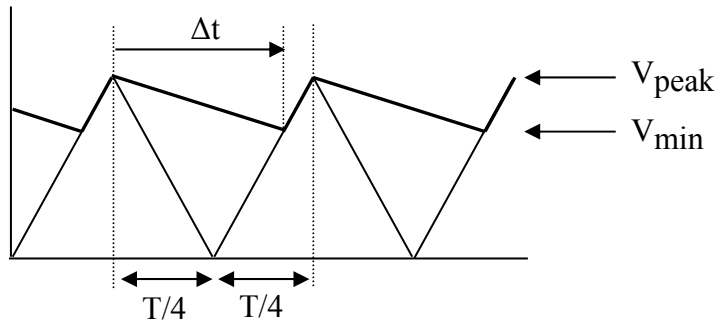

Figure 6. Approximation of Waveform Used for Ripple Calculation Formula

In that case, simple geometry shows the relationship between Δt and $(V_{peak} - V_{min})$ to be

$$\Delta t = \frac{T}{4} + \frac{V_{min}}{V_{peak}} \cdot \frac{T}{4} = \frac{T}{4} \left(1 + \frac{V_{min}}{V_{peak}} \right) , \text{ or}$$

$$\Delta t = \frac{T}{4V_{peak}} (V_{peak} + V_{min}) . \quad (3)$$

Substituting into (3) into (2) yields

EE462L, Power Electronics, Capacitor Filtered Diode Bridge Rectifier

Version January 25, 2014

$$(V_{peak} - V_{min}) = \frac{2P \frac{T}{4V_{peak}} (V_{peak} + V_{min})}{C(V_{peak} + V_{min})} = \frac{PT}{2CV_{peak}} \quad (4)$$

Since $T = \frac{1}{f}$, then the final expression for ripple becomes

$$(V_{peak} - V_{min}) = V_{peak-to-peak\ ripple} = \frac{P}{2fCV_{peak}} \quad (5)$$

For the circuit to be built (using 18 mF),

$$V_{peak-to-peak\ ripple} \approx \frac{200}{2 \cdot 60 \cdot 18000 \cdot 10^{-6} \cdot 28\sqrt{2}} = 2.33V \quad .$$

Expressed as a percent of peak voltage, the voltage ripple at 200 W load is approximately

$$\%V_{ripple} = \frac{V_{peak-to-peak\ ripple}}{V_{peak}} \approx \frac{2.33}{28\sqrt{2}} \cdot 100\% = 5.88\%$$

The Circuit

The schematic for the circuit that you will build is shown in Figure 7. If available, use a very thin layer of heat sink compound between the diode bridge rectifier module and its heat sink. To maximize effectiveness of the heat sink, make sure that the diode bridge rectifier module has good physical contact with the heat sink and no air gaps in between.

The heat sink should be mounted vertically and held into place by a steel corner bracket so that there is no gap between the heat sink and the wood.

EE462L, Power Electronics, Capacitor Filtered Diode Bridge Rectifier

Version January 25, 2014

Be very careful to connect the polarities of the diode bridge and capacitor properly. These components can be ruined, and capacitors can explode, if their polarities are reversed!

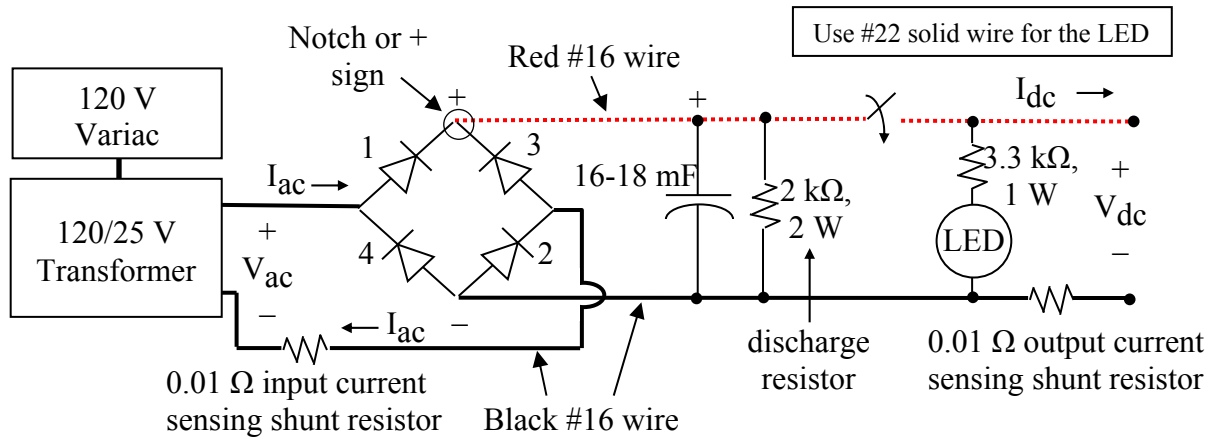

Figure 7. Schematic for Capacitor Filtered Diode Bridge Rectifier

(Note – use the variac to hold $V_{ac} = 28 \pm \frac{1}{2}$ Vrms during your experiment. Mount the DBR module with its flat (or + sign) pointed “up”. Mount the capacitor vertically. Mount the output switch so that “up” corresponds to the “on” position)

Note – to avoid accidentally shorting the capacitor, never try to measure the voltage directly across the capacitor terminals.

The 2 k Ω resistor across the capacitor is a discharge resistor that slowly discharges the capacitor after the circuit is de-energized. The 3.3 k Ω resistor is to limit current through the LED to just what’s required for it to illuminate. Thus, smaller gauge wire can be used here since it will be carrying minimal current.

By using the variac to slowly increase input voltage, short circuits or other problems in your circuit can hopefully be identified before damage is done.



Circuit Layout Showing Variac, 115:25 V Step-down Transformer, and DBR

EE462L, Power Electronics, Capacitor Filtered Diode Bridge Rectifier
Version January 25, 2014

Regarding the toggle switch – a hex nut goes on the inside of the steel corner bracket, and the lock washer and round nut go on the outside. Mount the hex nut so that it does not touch the body of the toggle switch. That way, when tightening, the pressure is on the hex nut instead of on the body of the toggle switch (see below)

Space left between hex nut and body of switch

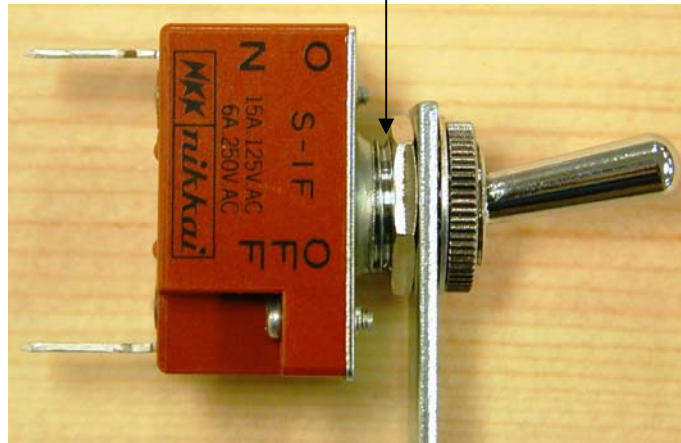

Warning – when connecting quick-disconnects to diode bridge rectifier modules and toggle switches, it is very easy to cut your fingers if you are not careful. The proper way is to hold the body of the rectifier module or toggle switch in one hand (or in a vise), and then use your long-nose pliers at a right angle to push the disconnect/wire onto the terminal.

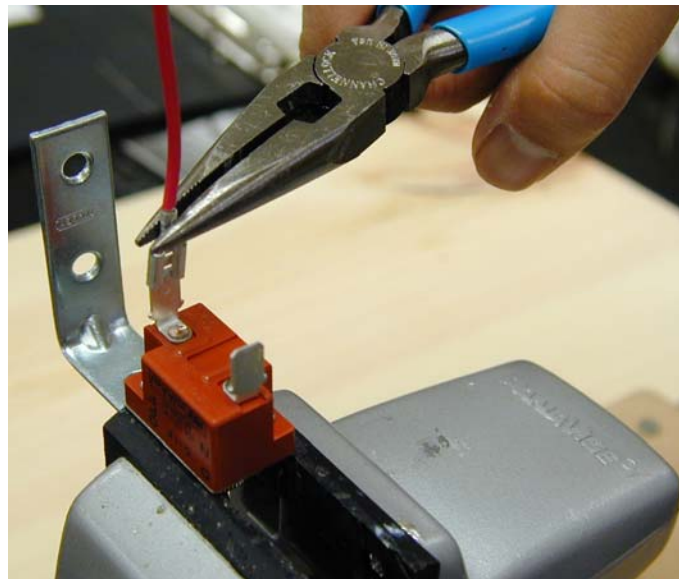

LED polarity – Polarity should be marked, but if not, this can be determined a few different ways:

- 1) The longer lead is generally the anode (+) of the diode, but don't always go by this convention. (*For, if the part has been reused, someone may not have ensured the anode remained the longer leg if they clipped off the leads.*)
- 2) Looking inside the LED lamp, the gap is off-centered and the portion with the majority of the filament, that contains the LED chip, is normally the cathode.
- 3) If you just read V_{dc} , it should be positive if probes are connected correctly (*see image below*). If you are getting a negative read, switch the multimeter probes. When you are reading positive V_{dc} , your red probe will indicate the positive LED terminal.
- 4) If you read the diode setting (*put meter on resistor / diode & press select until the diode symbol $-|>|$ comes up on your multimeter*).

If you have the probes correct, your LED may light up very dimly. It's difficult to see, but if you look closely, it should illuminate.

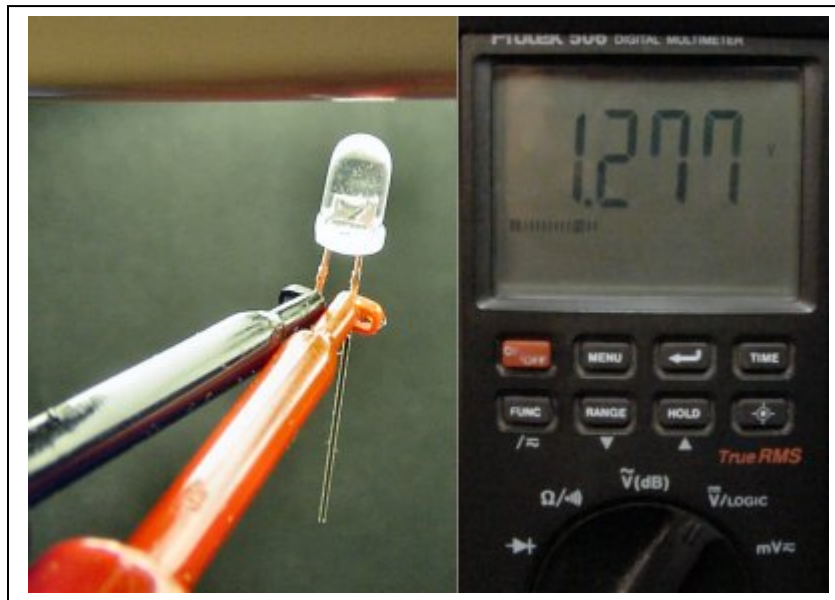
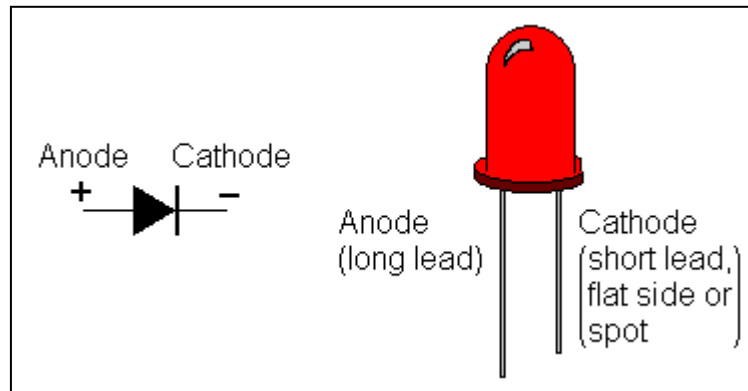

The Experiment

- A. **No Load Conditions.** Connect the 2 **outer** terminals of a red, 115:25 V step-down isolation transformer to the input of your unloaded DBR. Then, with a **variac turned off and its voltage control knob at zero**, plug the 115:25 V transformer into the variac outlet. Slowly raise the variac to a few volts and make sure that the variac current meter remains zero (which helps to check for downstream shorts). Then, **slowly** raise the variac so that the **transformer output is $28 \pm \frac{1}{2}$ Vrms**. (*Note: The 115:25 V transformer's red LED won't come on until the input voltage is over 90 Vrms.*) Use a multimeter to measure the “no load” values of V_{ac} and V_{dc} using the appropriate multimeter settings. Make sure you measure V_{dc} at your DBR's output terminals. View no-load V_{ac} on the oscilloscope. Then, move your oscilloscope probe and view no-load V_{dc} . The ripple voltage should be nearly zero.

Note: To measure dc ripple, the best way is to adjust your oscilloscope probe settings from dc biased to ac biased. This will remove the dc component, leaving you with a zoomed in trace of the ripple where you can measure peak-to-peak. To do this, press the Yellow “1” for your 1st O-scope probe and change the “Coupling” (bias). [Options are dc, ac, or ground]. Just make sure to change the Coupling back once you're finished!

Note – do not attempt to view V_{ac} and V_{dc} simultaneously on the oscilloscope because they have different ground reference points!

- B. **Measure the No Load (Ambient) Temperature of the Heat Sink** using a thermistor (see resistance-temperature characteristics in Table 1) and an ohmmeter. Clamp the thermistor to the top of the heat sink with a wooden clothes pin, so that the thermistor leads point upward. Wait a minute or so for the thermistor temperature to stabilize, and then measure its resistance. An example temperature calculation is shown below the table. Compare your thermistor temperature measurement to that read by one of the infrared thermometers (see a TA for the Fluke 561, IR thermometer).

Table 1: Resistance-Temperature Characteristics of GE Sensing, Inc., Negative Temperature Coefficient Thermistor Material Type D9.7A (Source: www.gesensing.com)

Temp T - °C	RT/R(T=25 °C)	Temp T - °C	RT/R(T=25 °C)
0	3.28	60	0.249
5	2.55	65	0.208
10	1.993	70	0.1752
15	1.573	75	0.1482
20	1.250	80	0.1258
25	1.000	85	0.1073
30	0.806	90	0.0919
35	0.653	95	0.0790
40	0.532	100	0.0682
45	0.437	105	0.0591
50	0.360	110	0.0513
55	0.298		

EE462L, Power Electronics, Capacitor Filtered Diode Bridge Rectifier

Version January 25, 2014

Example calculation: If the measured resistance of a nominal 1 k Ω (at 25 $^{\circ}$ C) thermistor is 360 Ω , then the thermistor temperature is 50 $^{\circ}$ C. If the thermistor resistance is 1993 Ω , then the thermistor temperature is 10 $^{\circ}$ C. Use linear interpolation between points. (*Note: Due to the wide range of resistance values for a thermistor, students may have to toggle between reading in k Ω and Ω on their multimeters.*) Unlike most materials, the resistance of a thermistor decreases with temperature. This property is used to trigger relays for hot warning lights and motor overheat protection.

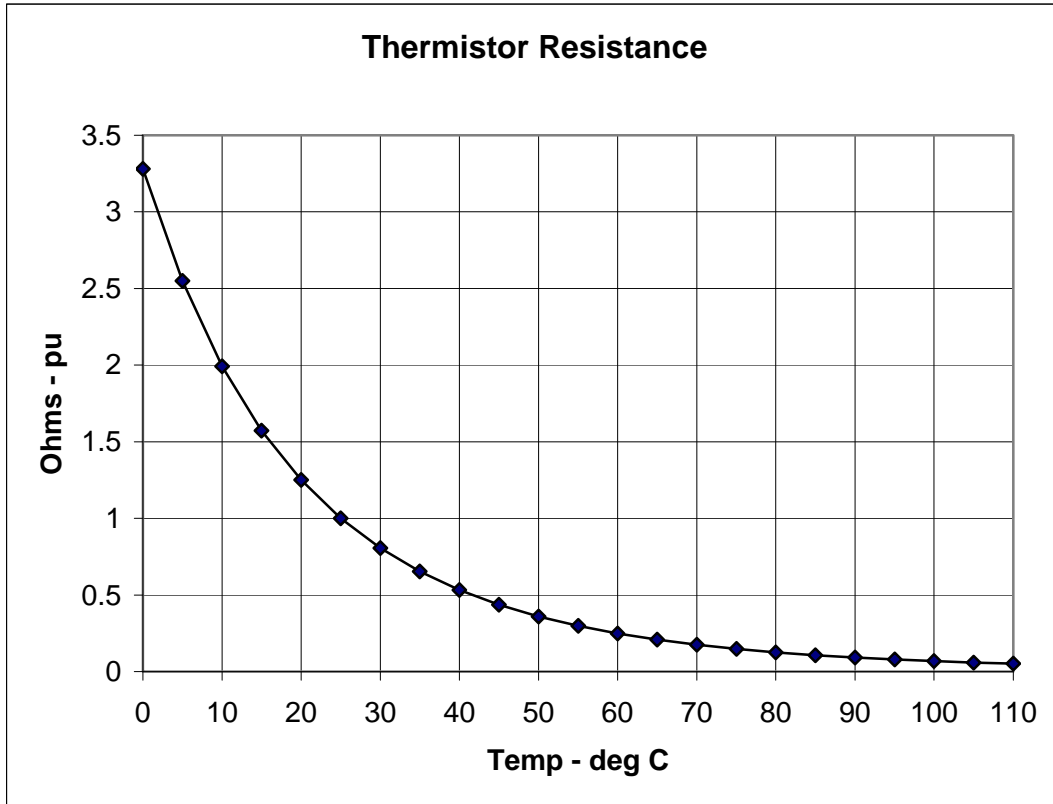

- C. **Five Ohm Load.** Connect a 5 Ω power resistor load to your DBR's output. Raise the variac to hold V_{ac} constant at $28 \pm \frac{1}{2} V_{rms}$ (Why did it dip?). Use a multimeter to measure V_{ac} , I_{ac} (using the voltage across the **body** of your 0.01 Ω input shunt resistor, excluding any extra wiring and contact resistance), V_{dc} , and I_{dc} (using the **body** of your 0.01 Ω output shunt resistor). Don't attempt to measure the R value of the shunt resistors (why?), just assume it to be exactly 0.01 Ω . Compute $P_{dc} = V_{dc} \cdot I_{dc}$. View V_{dc} on an oscilloscope, and use the oscilloscope to measure V_{peak} and the peak-to-peak ripple voltage.
- D. **Ten Ohm Load.** Repeat Step C, replacing the 5 Ω power resistor load with a 10 Ω power resistor (or two 5 Ω power resistors in series).
- E. **Diode Losses and Heat Sink Performance.** For the load condition in Step C, use an oscilloscope to view the forward voltage across one of the diodes in the bridge module. As illustrated on the following page, estimate the average forward voltage drop on the diode during its conduction interval.

EE462L, Power Electronics, Capacitor Filtered Diode Bridge Rectifier

Version January 25, 2014

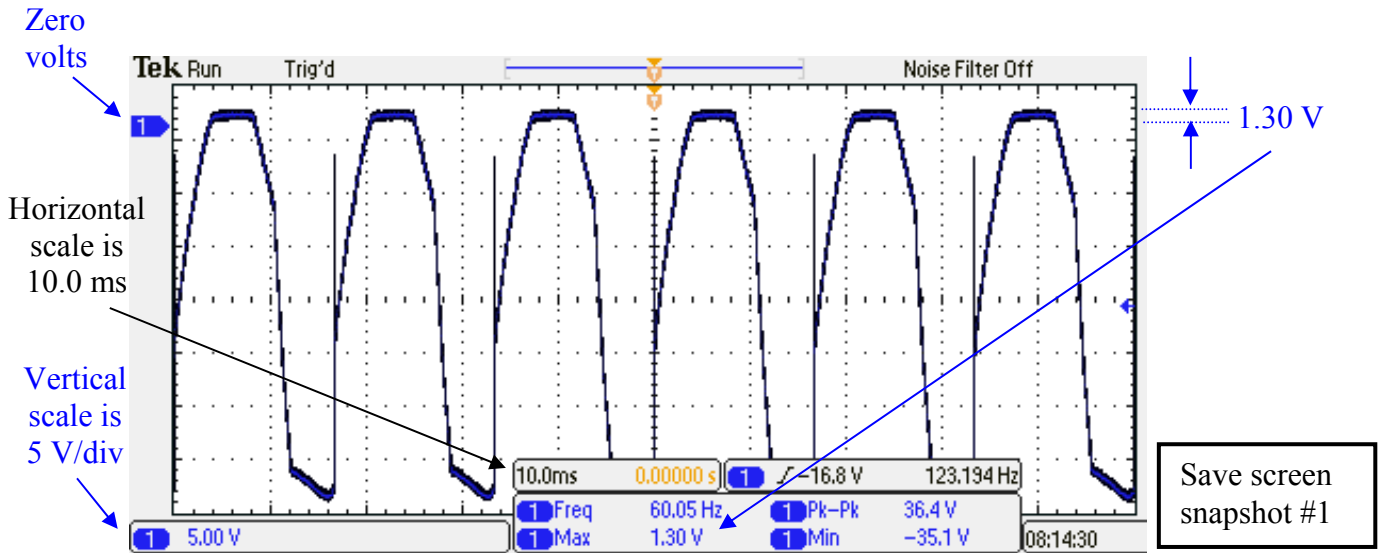
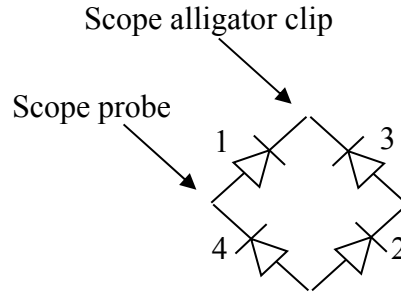

Example for Step E. Connecting the oscilloscope across one diode will display the forward voltage across one diode during conduction. The forward voltage drop is shown to be 1.30 V.

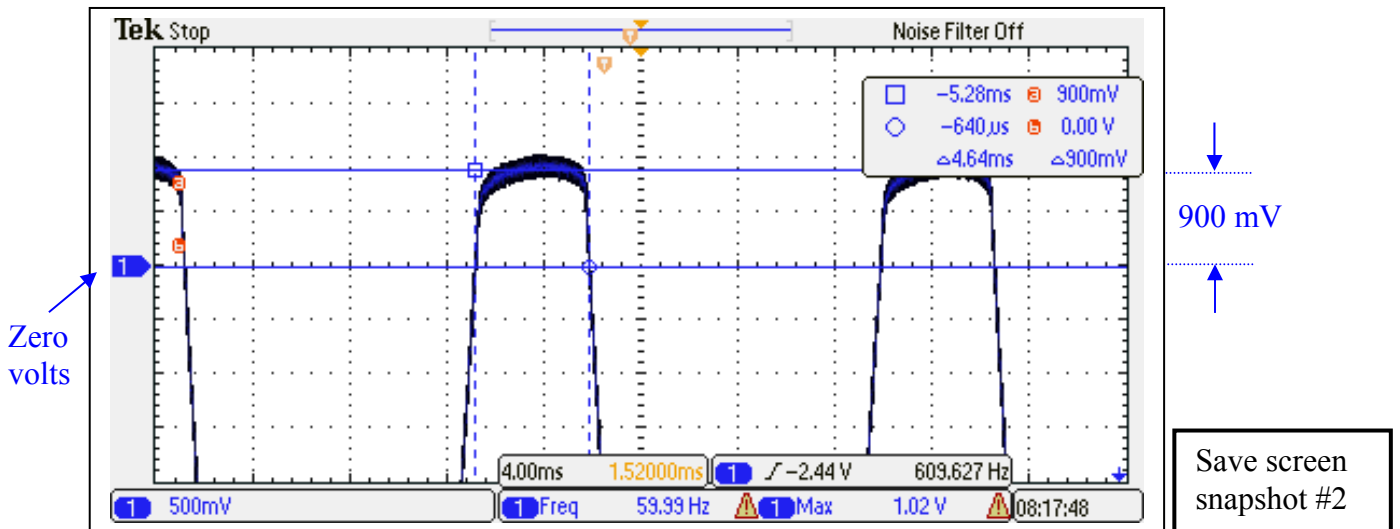

Example for Step E. “Zooming-in” on the forward voltage and using the cursors gives a more accurate reading of the average forward voltage drop. In this case, the average value is approximately 0.900 V. (Notice top horizontal line measurement is placed at an “average” value (not peak) for V_{diode} . Vertical line cursors measure T_{cond} to be approximately 4.64 ms.)

EE462L, Power Electronics, Capacitor Filtered Diode Bridge Rectifier

Version January 25, 2014

Next, use the oscilloscope to estimate the average ac current during one conduction pulse. Note – each diode sees one pulse of the ac current, once per cycle. Use the voltage and current averages to compute total average power loss on all four diodes as shown in (6) in the following figure.

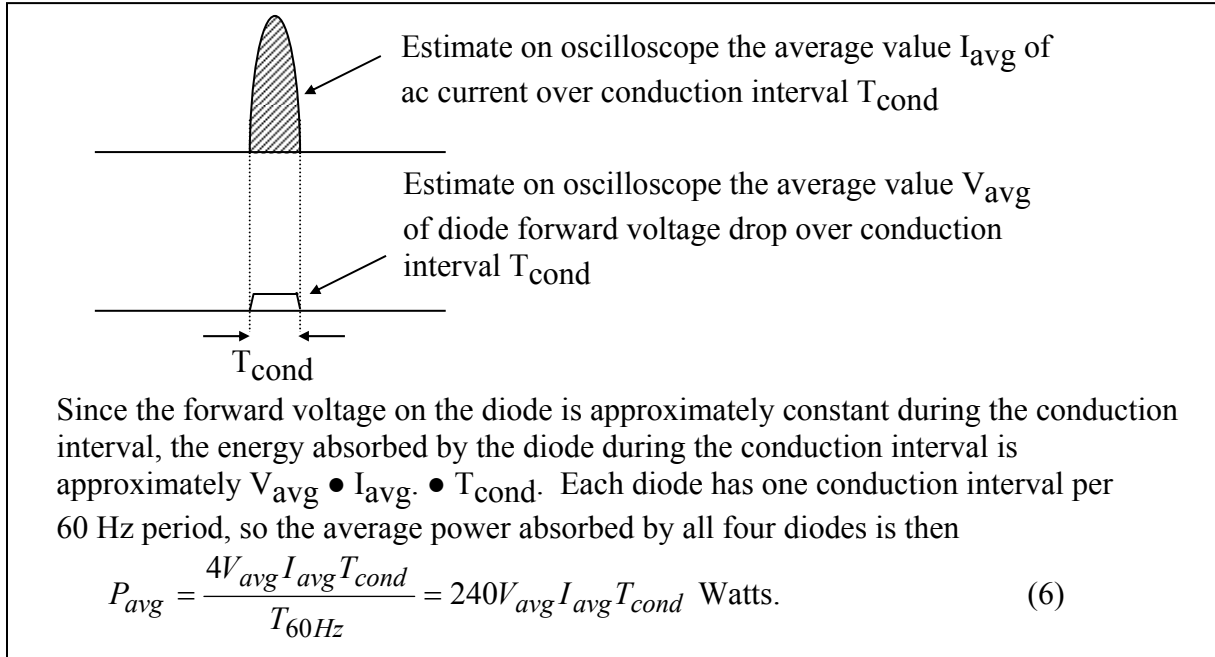

Example for Step E. The ac current is viewed by observing the voltage across the 0.01Ω input current sensing resistor. “Denoise” & “Freeze” your ac current to display it properly (see oscilloscope directions on the next page). By adjusting the cursors, the period is seen to be approximately 16.7 ms (i.e., 1/60 Hz).

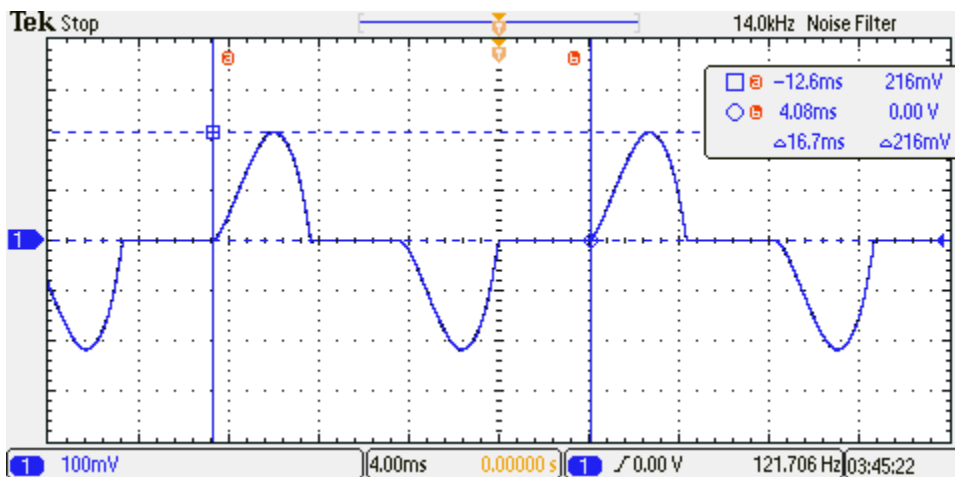

Save screen
snapshot #3

Measuring your “denoised” ac current can be accomplished 1 of 2 different ways:

- 1) If you press the “Acquire” button, there should be an option to turn Averaging ON or OFF. If you turn it ON, it should clean up your signal. However, if it changes your waveform too much and it no longer appears to look correct, turn Averaging back OFF again & try option 2:
- 2) Press the “FilterVu” button. This will allow you to screen out your higher frequency components. Dial the threshold down from 100 MHz down to the kHz range. Your minimal threshold will be dependent upon your horizontal scaling. *(For example, a 4.0 ms scaling gives a FilterVu min of 14 kHz, while 2.0 ms gives a FilterVu min value of 29 kHz.)* Your signal should clean up dramatically. The “fuzziness” should disappear, save for a ghost pattern left behind. To take off this ghost pattern, turn FilterVu “Glitch Capture Background” to OFF.

Lastly, if your waveforms jump around a lot, you can try a “Single” acquisition or try toggling the “Run/Stop” button to try to freeze and capture a nice AC waveform.

One pulse of the ac current passes through each diode pair. In the example shown above, the peak of the voltage pulse across the $0.01\ \Omega$ current shunt is 216 mV, corresponding to $0.216\ \text{V} \div 0.01 = 21.6\ \text{A}$. The conduction time is 4.64 ms. Because the pulse is approximately triangular, the average value during conduction is about $21.6 \div 2 = 10.8\ \text{A}$. *(A handy fact to remember is that with a $0.01\ \Omega$ current shunt, 10 mV corresponds to 1 A.)*

After the circuit has been operating with the $5\ \Omega$ load for at least five minutes, use a thermistor to measure the temperature of the heat sink. **Be careful as the $5\ \Omega$ power resistors will get very hot & emit a burning smell. This is expected, but please take heed not to burn yourself on the resistor!** Compute the $^{\circ}\text{C}$ rise above ambient (note – ambient temperature was measured in Step B). Use the power loss from (6) and the temperature rise to compute the thermal resistance coefficient of the heat sink (in $^{\circ}\text{C}$ rise per Watt). The manufacturer’s catalog thermal resistance value is approximately $2\ ^{\circ}\text{C}/\text{W}$. Compare your thermistor temperature measurement to that shown by one of the infrared thermometers. Consult with the TAs for the IR temperature readings.

- F. **Plot I_{dc} vs. V_{dc} for Steps A, C, and D.** Put I_{dc} on the vertical axis, and V_{dc} on the horizontal axis.
- G. **Plot Measured $\%V_{\text{ripple}}$ for Steps A, C, and D.** Put $\%V_{\text{ripple}}$ on the vertical axis, and P_{dc} on the horizontal axis.
- H. **Plot Theoretical $\%V_{\text{ripple}}$ for Steps A, C, and D.** Use (5) with the measured values of V_{peak} and P (i.e., $P = V_{\text{dc}} \cdot I_{\text{dc}}$). Superimpose the results of (5) on the plot from Step G.
- I. **Measurements vs. Theory.** Comment on the differences between Steps G and H.

- J. **Estimate the Capacitance of the Electrolytic Capacitor.** Switch off the transformer and connect the scope probes across the 5 Ω power resistor. Switch on the transformer. Set the scope vertical axis to 10 V/div, and the time axis to 100 ms/div. *(You can try 5 V/div, but make sure to move the probe's vertical position knob to ensure both the dc voltage ripple and 0 V are seen together onscreen. Else, go back to 10 V/div. You may also try a lower setting for the time axis if you can capture the entire discharge curve, down to 0 V. These smaller settings may even help you achieve more accurate C calculations.)*

Directions to Discharge Stored Electrolytic Capacitor Energy across a Load Resistor:

For waveform acquisition as the capacitor discharges into the load after the red, 115:25 Vrms isolation transformer has been switched off, please do the following to your oscilloscope:

- 1) Press the “Trigger” button. Make sure settings read “Edge”, “Source 1”, “DC coupling”, “FALLING” (not rising) slope, and change the Trigger Level to be something smaller than $28\sqrt{2}$ minus $\frac{1}{2}$ your ripple. So, something like 25 or 28 Vdc should be appropriate. *(Note: You can also adjust the Trigger Level by simply turning the Level knob by the Trigger section of the oscilloscope. You may see a horizontal line displaying your trigger level threshold onscreen. Make sure it's below the min voltage of your voltage ripple or your ripple will simply trip it.)*

Finally, Take “Mode” off Auto-Rolling by setting it to “Normal”.

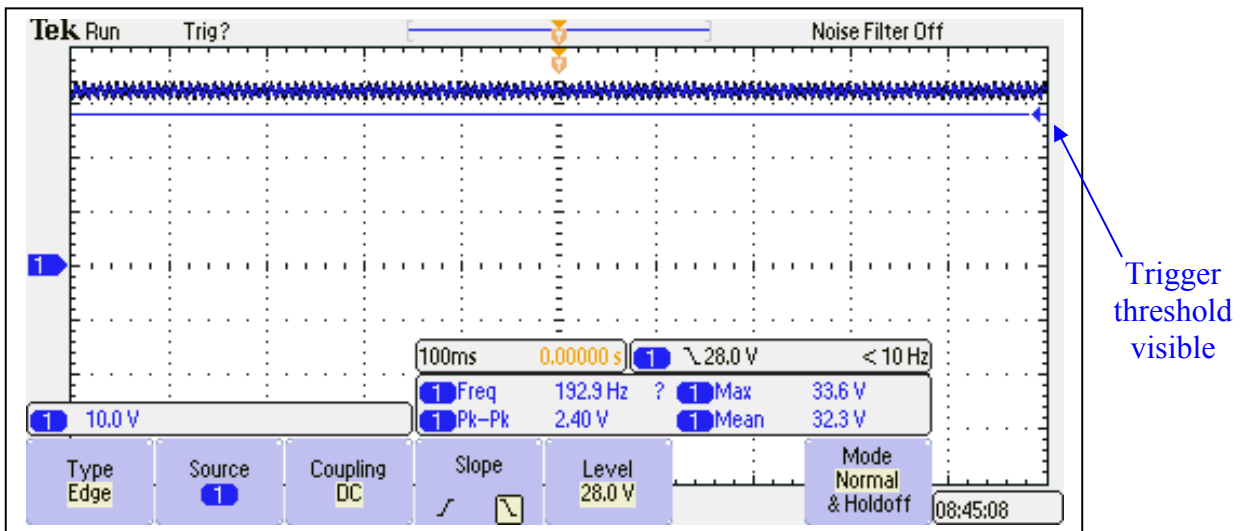

- 2) Now, press the button for “Single” for single screen capture post-Trigger. Now, your oscilloscope should show something like **Trig?** with a blank screen. Thus, it's waiting to be triggered – it's waiting for the waveform to fall below the threshold you set (25 or 28 Vdc).
- 3) Now, switch OFF the **ac-ac 115:25 V step-down isolation transformer** (not the DBR switch!), and it should capture your capacitor discharge curve nicely so you can then take measurements on the waveform to calculate your capacitance value.

EE462L, Power Electronics, Capacitor Filtered Diode Bridge Rectifier
Version January 25, 2014

You should see a response similar to the one shown below, save yours will show appropriate cursor measurements to validate your capacitor calculation. Recall the exponential decreases by the factor $e^{-1} = 0.368$ in one time constant $\tau = RC$ seconds. Thus, use the discharge curve, your cursor measurements, and the known R to estimate C. Then, compare it to the C rating stamped on the capacitor itself. Does your capacitance calculation fall within the C tolerance rating of the capacitor?

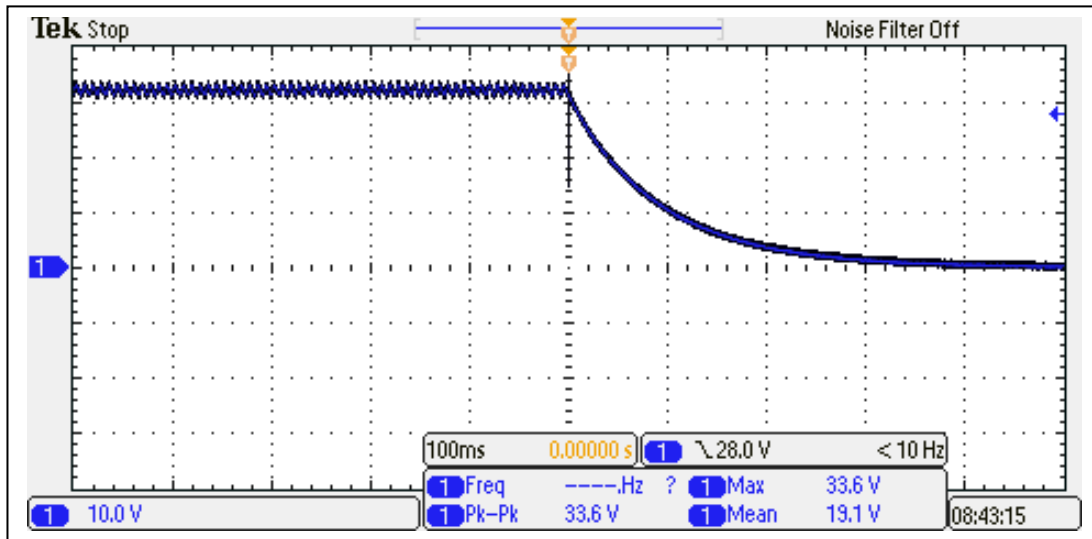

Save screen
snapshots #4 (5 Ω)
& #5 (10 Ω)

Finally, repeat Step J again using the 10 Ω power resistor as a load. Comment on differences seen in the ripple voltage and capacitor discharge rate between the 10 Ω and 5 Ω loads.

EE462L, Power Electronics, Capacitor Filtered Diode Bridge Rectifier

Version January 25, 2014

Parts List

- Five 2-terminal, 30 A terminal blocks, Molex/Beau, 38211-0102 (Mouser #538-38211-0102)
- 200 V, 35 A diode bridge rectifier module, Vishay Semiconductor, GBPC3502-E4/51 (Mouser #625-GBPC3502-E4), (note + and – terminals, and be careful with polarity!)
- One 3" by 4" heat sink, Wakefield, 641K, (Mouser #567-641-K, or Digikey # 345-1053-ND). Hole drilled with 5/32" bit, and de-burred to smooth surface, to fit 1½" steel corner bracket.
- 18000 µF, 50 V Cornell Dubilier computer-grade electrolytic capacitor, CGS183U050V3C (Mouser #539-CGS50V18000), with screws and lock washers (note + and – terminals, and be careful with polarity!). Alternatively, use 16000 µF, 50 V capacitors.
- Vertical mounting clamp with tightening screw for capacitor (For 18,000 µF, use Cornell Dubilier VR8, Mouser #539-VR8; for 16,000 µF, use Cornell Dubilier VR3, Mouser #539-VR3), or equivalent. (Clamp uses #6-32 x ½" to 1" machine screw and nut)
- Toggle switch, NKK Switches, S1F-RO, 125 V, 15 A with quick connect terminals (Mouser #633-S1F-RO)
- GE Measurement & Controls negative temperature coefficient thermistor, RL2004-582-97-D1, 1 kΩ at 25°C (Mouser #527-2004-1K)
- Wooden clothes pin to hold the thermistor firmly against heat sink fins to make a good thermal contact.
- Lumex Opto/Components Inc, LED red panel mount indicator light and assembly, SSI-LXR4815ID, T-1¾ (5 mm), approx. 30 mA (Mouser #696-SSI-LXR4815ID)
- 1½" steel corner bracket for mounting the heat sink (Stanley 30-3170, Home Depot).
- 2" steel corner bracket for mounting the switch (Stanley 30-3300, Home Depot). Hole in bracket enlarged with 15/32" drill bit to fit the toggle switch.
- 1" steel corner bracket for mounting LED. Hole in bracket enlarged with 5/16" drill bit to fit the LED indicator assembly.
- Two 0.01 Ω, 3 W metal element current sensing resistors IRC Advanced Film Division, LOB3R010JLF (Mouser #66-LOB3R010JLF), or Ohmite, 630HR010E (Mouser #588-630HR010E, Digikey #630HR010-ND) (in student parts bin)
- 2 kΩ, 2 W resistor (in student parts bin)
- 3.3 kΩ, 1 W resistor (in student parts bin)
- 1" x 6" wood (approx. 12" long piece)

Extra parts for the student parts bin and screw cabinet, at least

- 5 of the thermistors
- 5 of the LEDs

Plastic bags for parts

- 6"x6", 4mil for small parts
- 8"x10", 6mil for holding everything

EE462L, Power Electronics, Capacitor Filtered Diode Bridge Rectifier
Version January 25, 2014

#8-32, 1" machine screw, flat washer, split washer, and hex nut for mounting DBR module to heat sink

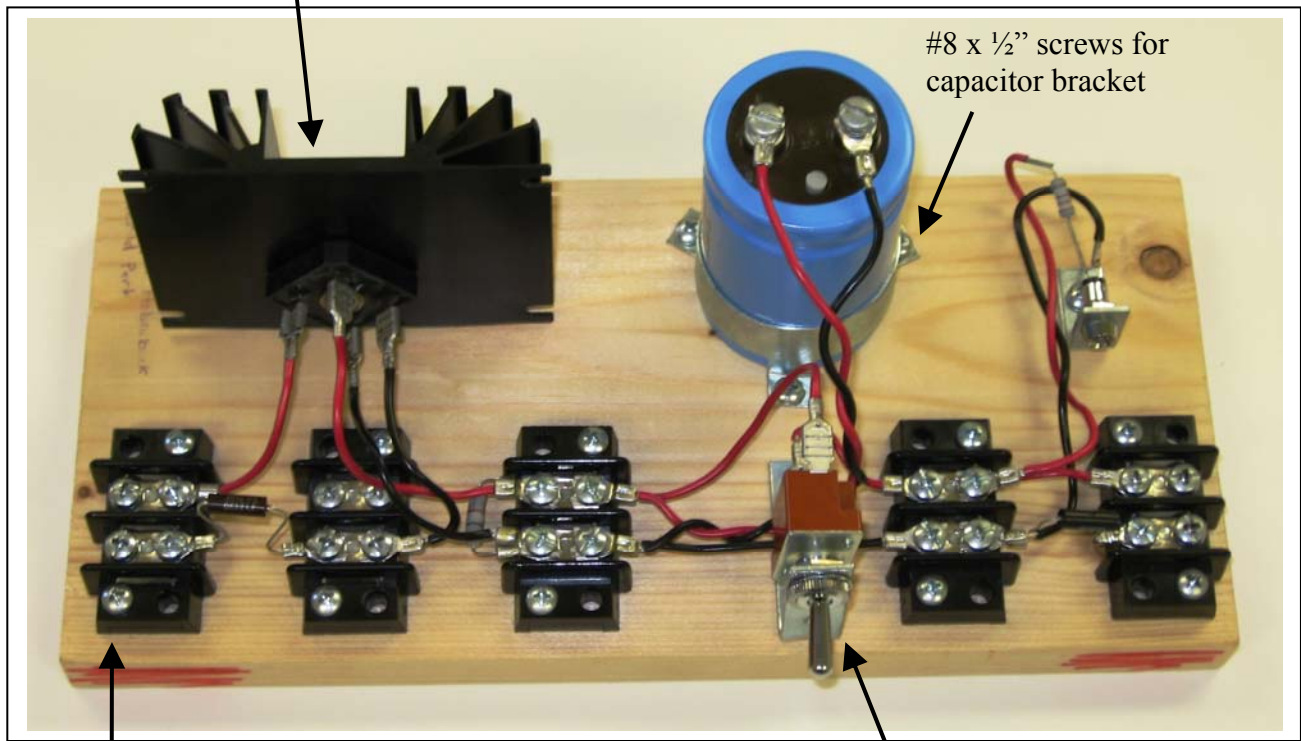

#8 x 3/4" screws for terminal blocks

#8 x 1/2" screws for corner brackets

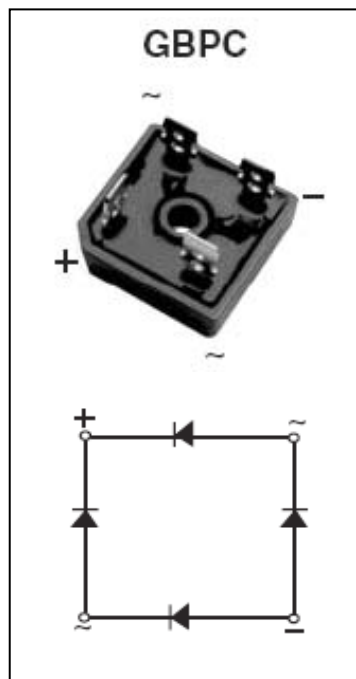

200 V, 35 A Vishay Semiconductor DBR Module