

EE462L, Power Electronics, DC-DC Buck Converter
Version February 8, 2014

1	Overview.....	1
2	Theory of Operation.....	1
2.1	Relation Between V_{out} and V_{in} in Continuous Conduction	1
2.2	Inductor Current in Continuous Conduction.....	3
2.3	Discontinuous Conduction.....	5
2.4	Capacitor Ripple Voltage in Continuous Conduction	5
3	Component Ratings.....	7
3.1	Inductor and Capacitor Ratings	7
3.2	Diode Ratings.....	8
3.3	MOSFET Ratings.....	8
4	The Experiment.....	9
5	Parts List	16

1 Overview

DC-DC converters provide efficient conversion of dc voltage from one level to another. Specifically, the term “buck” converter means that the converter takes input from a higher voltage level, e.g. variable 36-42 V_{dc} from solar panels, and converts it to a lower voltage level, e.g. fixed 12 V_{dc} , for powering equipment.

2 Theory of Operation

2.1 Relation Between V_{out} and V_{in} in Continuous Conduction

The idealized buck converter circuit is shown below in Figure 1. Input voltage V_{in} is assumed to be ripple free. The power electronic switch opens and closes at a fixed rate of, for example, 100 kHz, and its duty cycle is varied to control V_{out} . Capacitor C is assumed to be large enough so that V_{out} has a ripple of less than 5% and is therefore, essentially ripple free. I_{out} is also assumed to be ripple free. In normal operation, the circuit is in “continuous conduction,” e.g. i_L is always greater than zero.

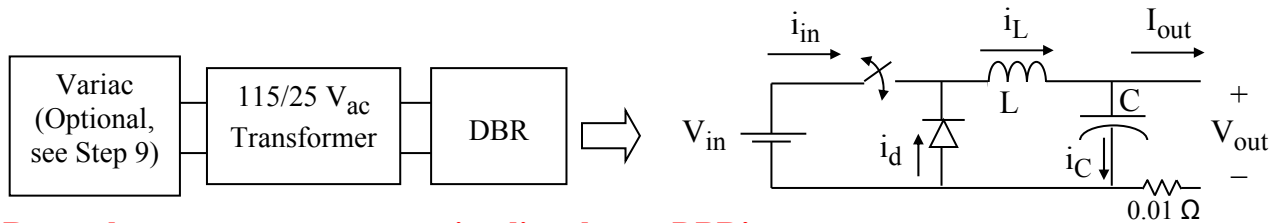

Remember – never connect a variac directly to a DBR!

Figure 1. DC-DC Buck Converter

(Note - you will mount a 0.01 Ω shunt resistor at the negative V_{out} terminal to measure output current, and a 10 μF ripple current capacitor across the V_{in} terminals to reduce overshoot caused by lead inductance)

The circuit is assumed to be lossless so that $P_{in} = P_{out}$, so

$$V_{in} \cdot i_{in,avg} = V_{out} \cdot I_{out} \quad (1)$$

Assuming continuous conduction, the circuit has two states: switch closed and switch open as shown in Figures 2a and 2b respectively.

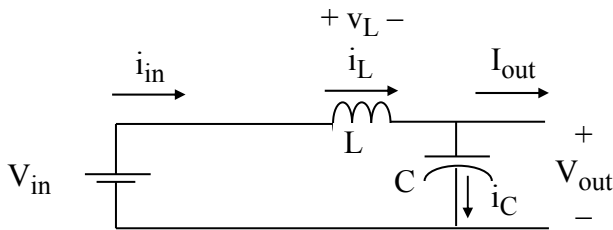

Figure 2a. Switch Closed for DT Seconds

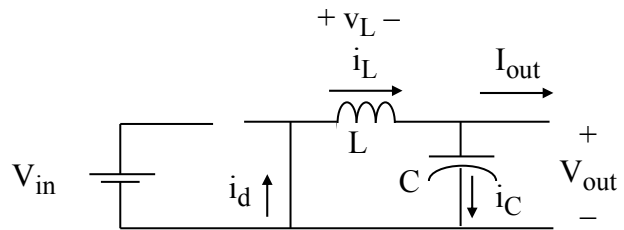

Figure 2b. Switch Open for $(1-D)T$ Seconds (Continuous Conduction)

When the switch is closed, the diode is reverse biased and open, and i_L increases at the rate of

$$\frac{di_L}{dt} = \frac{v_L}{L} = \frac{V_{in} - V_{out}}{L}, \quad 0 \leq t \leq DT, \quad \text{[KVL, from Figure 2a.]} \quad (2)$$

and the inductor is charging. When the switch is open, i_L continues to circulate through the diode, the diode is forward biased, i_L decreases at the rate of

$$\frac{di_L}{dt} = \frac{v_L}{L} = \frac{-V_{out}}{L}, \quad DT < t < T, \quad \text{[KVL, from Figure 2b.]} \quad (3)$$

and the inductor is discharging. The inductor voltage is shown in Figure 3.

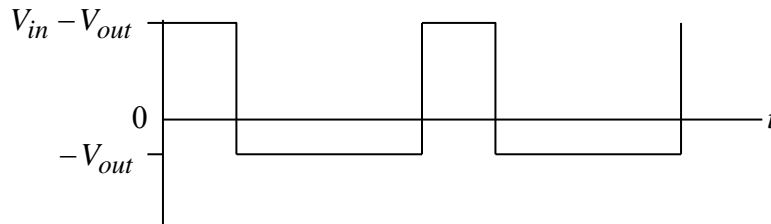

Figure 3. Inductor Voltage in Continuous Conduction

Because of the steady-state inductor principle, the average voltage v_L across L is zero. Since at any time v_L takes on one of two constant values, its average value is

$$\frac{(V_{in} - V_{out})DT + (-V_{out})(1-D)T}{T} = 0, \quad \text{so that}$$

$$V_{in}D - V_{out}D - V_{out} + V_{out}D = 0 .$$

Simplifying the above yields the final input-output voltage expression for a Buck converter:

$$V_{out} = V_{in}D . \quad (4)$$

2.2 Inductor Current in Continuous Conduction

Equations (2) and (3) give the rate of rise and fall of i_L . The average value of i_L is found by first examining the node at the top of capacitor C in Figure 1. Applying KCL in the average sense, and recognizing that the average current through a capacitor operating in steady state is zero, it is apparent that

$$i_{L,avg} = I_{out} \quad (5)$$

Equations (2), (3), and (5) provide the necessary information to draw a graph of i_L , as shown in Figure 4.

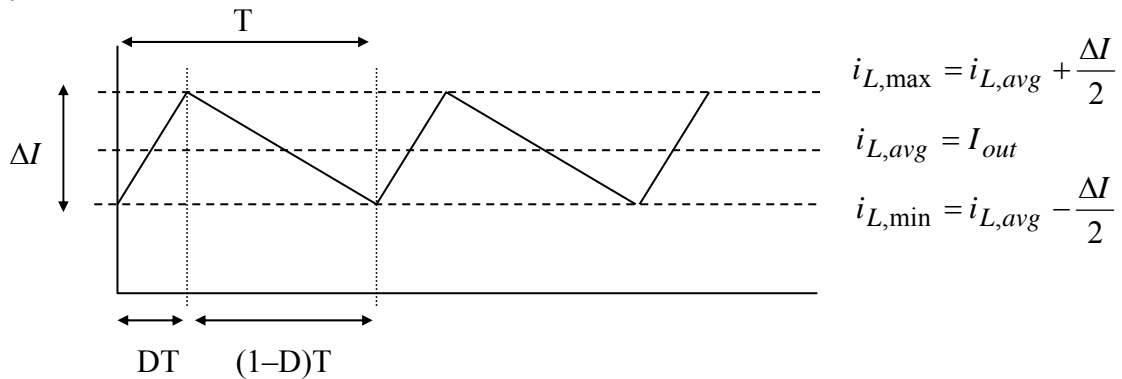

Figure 4. Inductor Current Waveform for Continuous Conduction

Because the current consists of straight line segments, it is apparent that

$$i_{L,avg} = \frac{i_{L,max} + i_{L,min}}{2} , \quad i_{L,max} = i_{L,avg} + \frac{\Delta I}{2} , \quad i_{L,min} = i_{L,avg} - \frac{\Delta I}{2} .$$

From (2),

$$\frac{di_L}{dt} = \frac{V_{in} - V_{out}}{L} = \frac{\Delta I}{DT} ,$$

so that

$$\Delta I = \frac{V_{in} - V_{out}}{L} \cdot DT = \frac{V_{in} - DV_{in}}{L} \cdot DT = \frac{V_{in}D(1-D)}{Lf} \quad (6)$$

where f is the switching frequency. Taking the derivative of (6) with respect to D and setting it to zero shows that ΔI is maximum when $D = 0.5$. Thus,

$$\Delta I_{\max} = \frac{V_{in}}{4Lf} \quad (7)$$

Through the definition of rms, it can be shown that the squared rms value of the triangular waveform in Figure 4 is

$$I_{rms}^2 = I_{avg}^2 + \frac{1}{12}(\Delta I)^2 \quad (8)$$

(Question – can you develop the above expression from the rms integral?)

The boundary of continuous conduction is when $i_{L\min} = 0$, as shown in Figure 5.

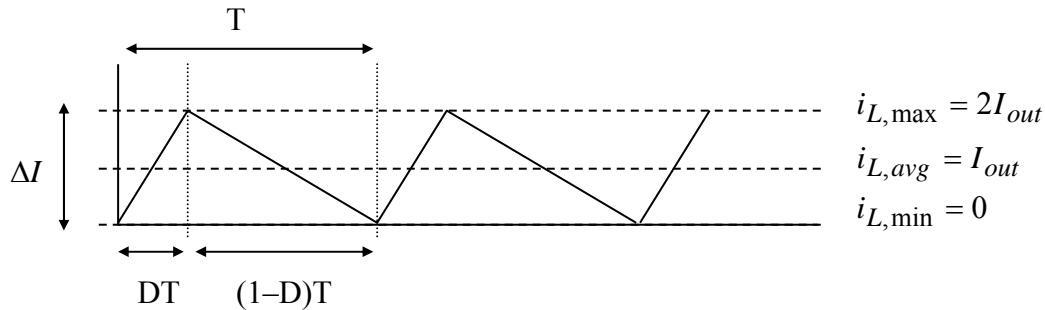

Figure 5. Inductor Current at the Boundary of Continuous Conduction

As shown, when at the boundary, $\Delta I = 2i_{L,avg} = 2I_{out}$. Using Figure 5 and the “inductor discharging” slope in (3), we get

$$\frac{-V_{out}}{L_{boundary}}(1-D)T = \frac{-V_{out}}{L_{boundary}f}(1-D) = -2I_{out},$$

$$L_{boundary} = \frac{V_{out}(1-D)}{2I_{out}f}, \quad (9)$$

where $L_{boundary}$ is the value of L that causes the circuit to operate at the boundary of continuous conduction for the given values of V_{out} , I_{out} , D , and f . The maximum required value of $L_{boundary}$ occurs when $D \rightarrow 0$. Therefore the value of L shown in (10),

$$L > \frac{V_{out}}{2I_{out}f} \quad (10)$$

will guarantee continuous conduction for all D. Note in (10) that continuous conduction can be achieved more easily (i.e. the required L is smaller) when I_{out} and f are large.

2.3 Discontinuous Conduction

At low load periods, the converter may transition into the discontinuous conduction mode. Referring back to Figure 2b, this occurs when the inductor current decreases to zero. At that moment, the capacitor attempts to reverse i_L and “backfeed” the inductor, but reversal is prevented by the freewheeling diode (for this discussion we will ignore the practical effect of diode reverse recovery current). Thus, the freewheeling diode opens, and the circuit assumes the state shown in Figure 6 until the switch closes again. During this third state, all load power is provided by the capacitor.

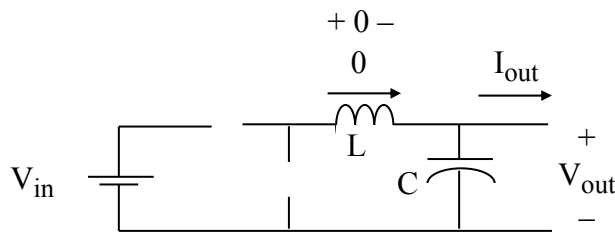

Figure 6. Third State for Discontinuous Conduction

Once discontinuous, the voltage across the inductor is zero. The corresponding voltage waveform is shown in Figure 7.

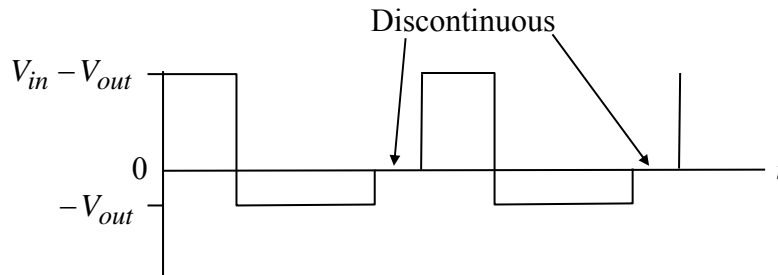

Figure 7. Inductor Voltage in Discontinuous Conduction

2.4 Capacitor Ripple Voltage in Continuous Conduction

For the upper node of the capacitor C in Figure 1, KCL requires that

$$i_C = i_L - I_{out} .$$

Then, considering Figure 4, capacitor C must be charging when i_L is greater than I_{out} , and discharging when i_L is less than I_{out} , as shown in Figures 8, 9, and 10.

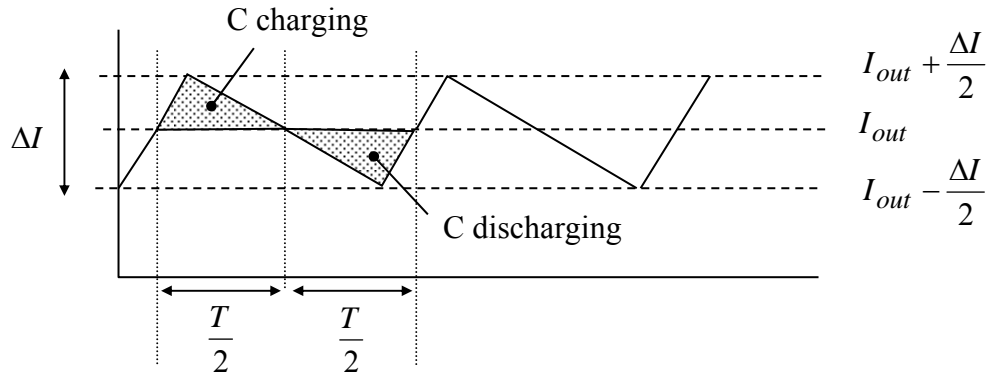

Figure 8. Inductor Current Graph Used to Illustrate Capacitor Charging and Discharging Intervals in Continuous Conduction

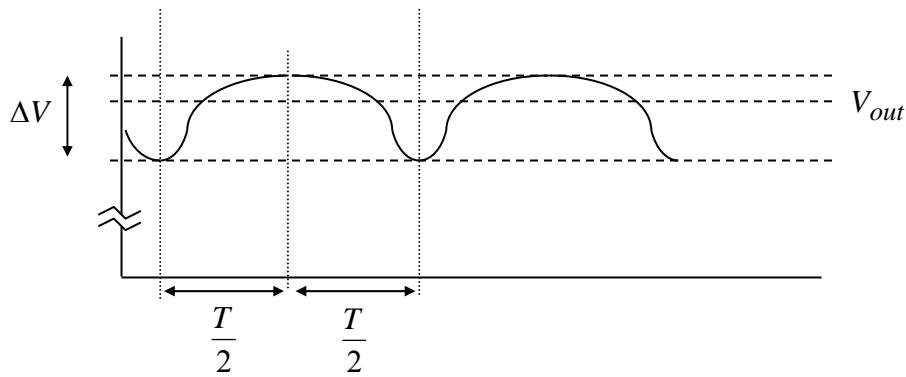

Figure 9. Capacitor Voltage in Continuous Conduction

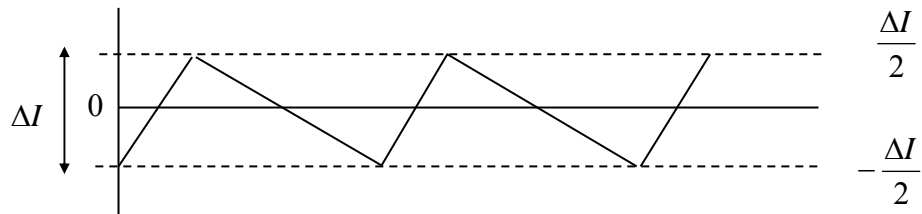

Figure 10. Capacitor Current in Continuous Conduction

Each charging and discharging area in Figure 8 lasts for $\frac{T}{2}$ seconds, and each area represents a charge increment ΔQ for the capacitor. The net charge flowing into the capacitor for one period must be zero in steady-state so that the capacitor voltage is periodic. Using

$$\Delta V = \frac{\Delta Q}{C} \quad (11)$$

and the area of the triangular charging region in Figure 8, the peak-to-peak ripple voltage on C must be

$$\Delta V = \frac{\Delta Q}{C} = \frac{1}{C} \cdot \frac{1}{2} \cdot \frac{T}{2} \cdot \frac{\Delta I}{2} = \frac{T\Delta I}{8C} \quad (12)$$

For the worst case, $\Delta I = 2I_{out}$, so

$$\Delta V = \frac{T}{8C} \cdot 2I_{out} \quad (13)$$

Thus, the **worst case peak-to-peak voltage ripple** on C is

$$\Delta V = \frac{I_{out}}{4Cf} \quad (14)$$

3 Component Ratings

3.1 Inductor and Capacitor Ratings

The inductor must have a sufficient rms current rating to safely conduct the current shown in Figure 4. The capacitor must support the maximum output voltage (i.e., corresponding to V_{in} when $D = 1$, from Equation (4)) and the rms ripple current shown in Figure 10. The ripple currents (i.e., total current minus average value) in Figures 4 and 10 are identical because of KCL at the node above C in Figure 1.

A conservative estimate for rms inductor current occurs when

$$\Delta I_{\max} = 2I_{out} \quad (15)$$

which when substituted into (8) yields

$$I_{Lrms,\max}^2 = I_{out}^2 + \frac{1}{12}(2I_{out})^2 = I_{out}^2 \left(1 + \frac{1}{3}\right), \quad (16)$$

so that

$$I_{Lrms,\max} = \frac{2}{\sqrt{3}}I_{out} \quad (17)$$

The same ripple current ΔI also flows through C, but C has no average current. Using the same logic as in (15), the maximum squared rms current through C becomes

$$I_{C,rms,\max}^2 = 0 + \frac{1}{12}(\Delta I)^2 = \frac{1}{12}(2I_{out})^2 = \frac{I_{out}^2}{3}, \quad (18)$$

so that

$$I_{C,rms,max} = \frac{I_{out}}{\sqrt{3}} \quad (19)$$

A conservative capacitor voltage rating is $1.5V_{out}$.

3.2 Diode Ratings

For the diode, a conservative voltage rating is $2V_{in}$ because of the oscillatory ringing transients that invariably occur with parasitic inductances and capacitances. To determine the current rating, examine the graph of diode current shown in Figure 11.

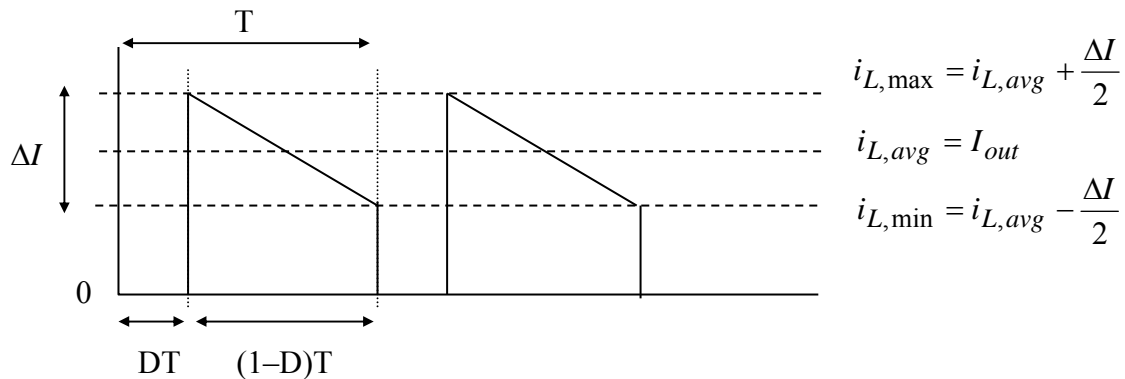

Figure 11. Diode Current Waveform for Continuous Conduction

A conservative assumption for diode current is to assume small D , so that the diode current is essentially the same as the inductor current. Thus, a conservative estimate is that diode rms current equals the inductor rms current given by (17).

3.3 MOSFET Ratings

It is clear in Figure 1 that the MOSFET must conduct inductor current when closed, and hold off V_{in} when open. The actual voltage rating of the MOSFET should be at least twice V_{in} to allow for the oscillatory ringing transients that invariably occur. To determine the current rating, examine the graph of the MOSFET current shown in Figure 12.

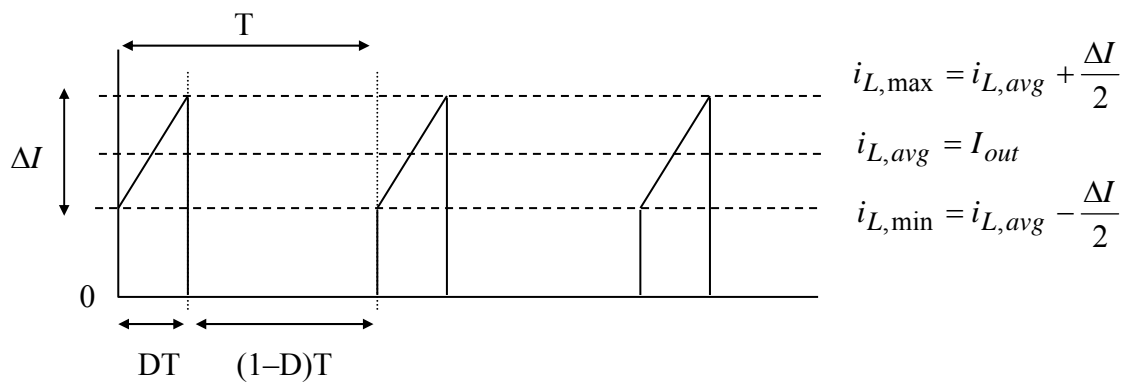

Figure 12. MOSFET Current for Continuous Conduction

To be conservative, a large value of D is assumed, so that the MOSFET current is essentially the same as the inductor current. Thus, a conservative estimate is that MOSFET rms current equals the inductor rms current given by (17).

4 The Experiment

- Using a 10" long piece of 1" by 6" wood, develop a plan for the layout of the circuit. This board will contain only the buck converter. The MOSFET firing circuit will connect at the top left terminal block in the Figure below. Use #16 stranded wire for power wiring (red for $+V_{dc}$, black for $-V_{dc}$).

Keep jumper connections short, ≈ 3 inches or less.

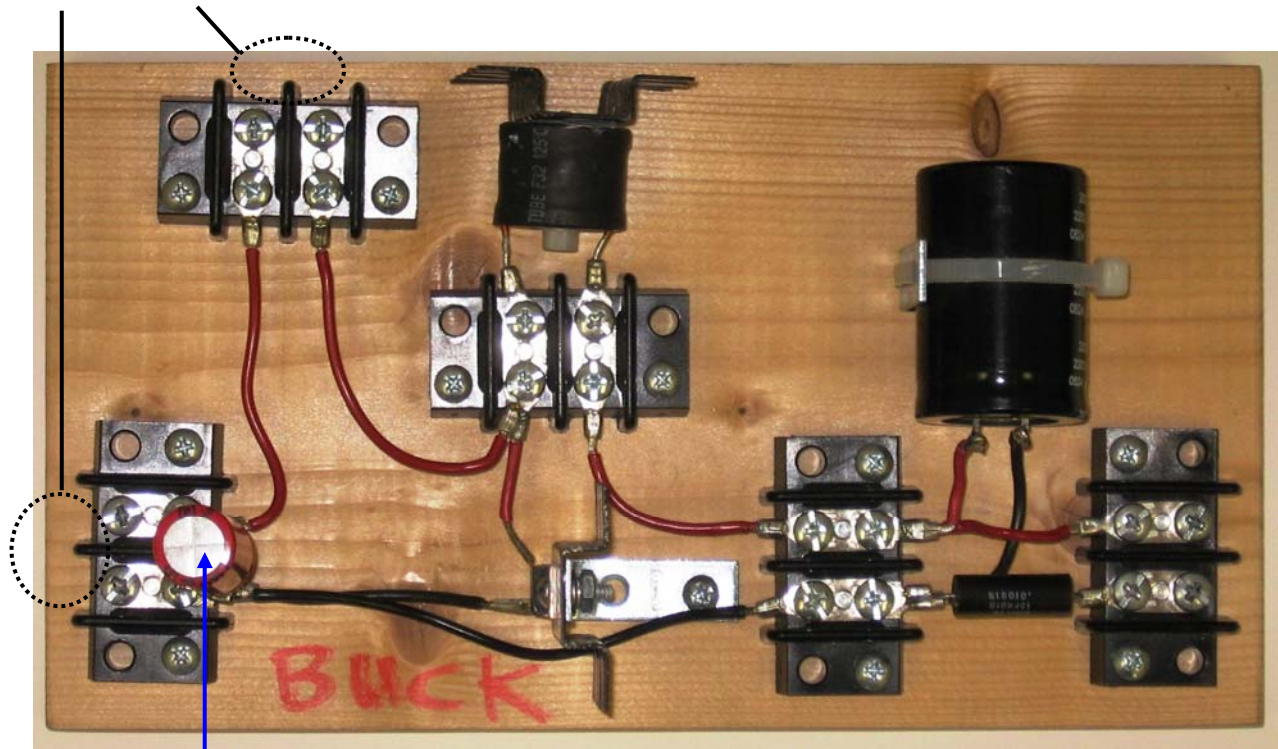

Mount $10\mu\text{F}$ ripple current capacitor across the input terminals

- Use the diode feature on your multimeter to identify the anode (+) and cathode (-) leads of the diode. (Or, refer back to your DBR lab document for suggestions on determining diode polarity.) **Be very careful with the diode polarity because, if it is connected backward, it will short circuit the input voltage when the MOSFET switch is closed.**
- Complete the wiring of the circuit in Figure 1, using #16 stranded red and black wire for (+) and (-) current carrying connections, respectively. Regarding the output filter capacitor, look for the wide stripe printed on one side of the package (often with negative signs), this graphic indicates the negative terminal. **Be extra careful of this electrolytic capacitor's polarity, as it may rupture if connected backwards!** Secure the output filter capacitor to a $1\frac{1}{2}$ " steel corner bracket with a nylon cable tie. Secure the inductor to its heat sink with a

EE462L, Power Electronics, DC-DC Buck Converter

Version February 8, 2014

nylon screw and nut. Secure the diode and its heat sink to a 1½” steel corner bracket, using a #6-32 x ½” machine screw, flat washer, split washer, and nut. Be sure to use a thin layer of heat sink compound (*if available*) when attaching the inductor and diode to their respective heat sinks.

4. Mount a 10 μF ripple current capacitor across the V_{in} terminals. Note this capacitor is bipolar (not polarized), thus polarity is not important. (*This capacitor will remain in place when you modify your circuit later to become Boost and SEPIC converters.*)
5. **Do not yet energize your circuit with a DBR.**
6. **Remove and discard the MOSFET snubber capacitor.**
7. Connect a 12 V_{dc} regulated “wall wart” to the dc jack of a MOSFET firing circuit. Observe V_{GS} on an oscilloscope while varying D and f over their ranges. V_{GS} should have the desired rectangular appearance, and D and f should have the desired ranges.
8. Connect the MOSFET firing circuit to your buck converter, **keeping the wires short (i.e., 3” or less). Do not accidentally connect your buck converter to the MOSFET gate terminal.** Then, connect a 10 Ω power resistor to the output of your buck converter.

Important Note: the first time you energize your converter, it is a good idea to feed the 115/25V transformer and DBR through a variac. That way, you can gradually increase the voltage and detect short circuits or other problems before they become serious. The ammeter on the variac is an excellent diagnostic tool. Once you are convinced that your circuit is working correctly, then you can remove the variac.

If your circuit has a short, please troubleshoot accordingly:

1. Make sure that your diode is not connected backwards.
2. Observe V_{GS} on the MOSFET as you vary D and f . Does the waveform look correct?
3. Unplug the wall wart. Does the short circuit go away? If not, your MOSFET may be shorted – so, disconnect the MOSFET from the converter, and perform the voltage-controlled resistance test on the MOSFET or ask a TA for assistance.

9. Connect a 115:25 V_{ac} transformer to your DBR. Connect the DBR to your buck converter, **keeping the wires short (i.e., 3” or less).** Then, energize the 115:25 V_{ac} transformer and DBR. If using a variac, adjust the variac so that the output of the **transformer** is 27-28 V_{ac} .

EE462L, Power Electronics, DC-DC Buck Converter
Version February 8, 2014



Picture 1: Buck Converter Laboratory Test Setup

10. Using the $10\ \Omega$ load, and with $f = 50\ \text{kHz}$, adjust D over the range 0.90 to 0.10, in steps of 0.10, while recording V_{in} and V_{out} . Compare the $V_{\text{out}}/V_{\text{in}}$ ratio to theory, and plot the measured ratios and theoretical ratios versus D on one graph. For $D = 0.90$, obtain I_{in} and I_{out} by measuring the voltages across the bodies of the $0.01\ \Omega$ shunt resistors. Multiply by the appropriate voltage to get P_{in} and P_{out} , and then determine the efficiency of your buck converter. Check to see if your MOSFET, diode, inductor, or output capacitor are “hot.”
11. Repeat the above step, using a $5\ \Omega$ resistor as a load.
12. With $50\ \text{kHz}$, $D = 0.90$, and the $5\ \Omega$ load, use (5), (6), and (8) to compute inductor rms current. Use (6) and (8), with $I_{\text{avg}} = 0$, to compute capacitor rms current.
13. Keeping $D = 0.90$ and using the $5\ \Omega$ load, lower f to its minimum (15-20 kHz). Use your oscilloscope to measure the peak-to-peak ripple voltage of V_{in} and V_{out} . Measure via ac coupling. Use Filter Vu to clean up your waveform by filtering out higher order harmonics. (Recall: Dial down the Noise Filter (Foreground) using multipurpose knob (a), and turn Glitch Capture Background “Off”.) You may also need to do a “Single” acquisition or toggle Run/Stop to freeze your waveform. (Question: Why is your ripple frequency 120 Hz, not 60 Hz?)

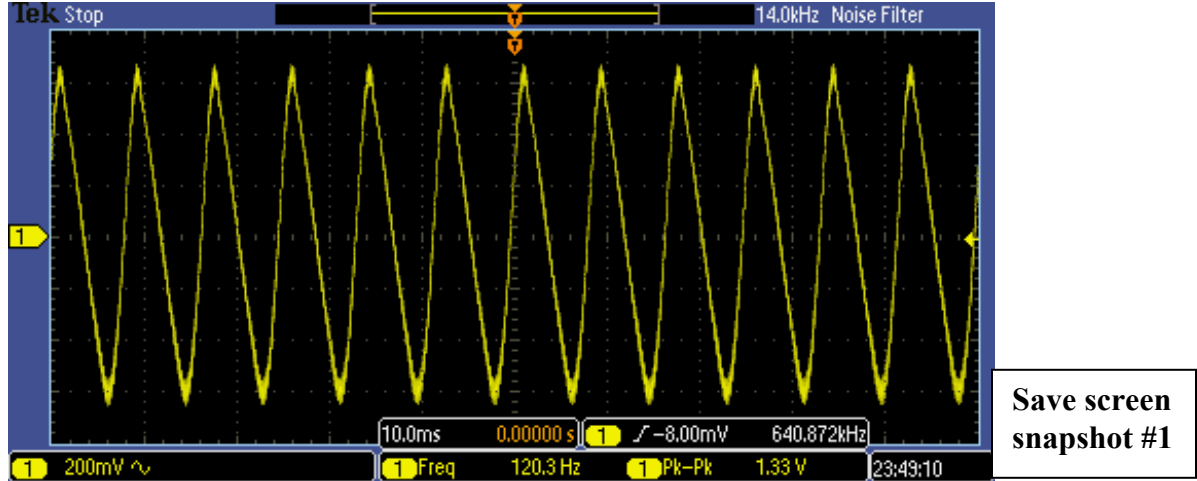

Picture 2: Peak-to-Peak Ripple Current (5 Ω Load, D = 0.9, f = 15-20 kHz)

14. Approximating the V_{out} ripple waveform as a triangle wave, estimate its rms value using

$$V_{rms}^2 = \frac{V_{pp}^2}{12}, V_{rms} = \frac{V_{pp}}{\sqrt{12}} = \frac{V_{pp}}{2\sqrt{3}}. \text{ (for the example above, the result is } V_{rms} = 0.375 \text{ V)}$$

Compare the calculation result to that shown by a multimeter “ac” measurement.

15. Zoom-in the time scale to 20 μsec/div, vertical scale of 50 mV/div, and observe the 15-20 kHz component of V_{out} . Freeze the frame using “Single” acquisition to take out the superimposed 120 Hz background ripple, with Filter Vu still on. (*Note: It may take you several tries to capture a nice, centered waveform.*) Compare the V_{pp} on the scope to the “worst case” predicted by (14). Repeat the triangle-wave assumption V_{rms} calculation.

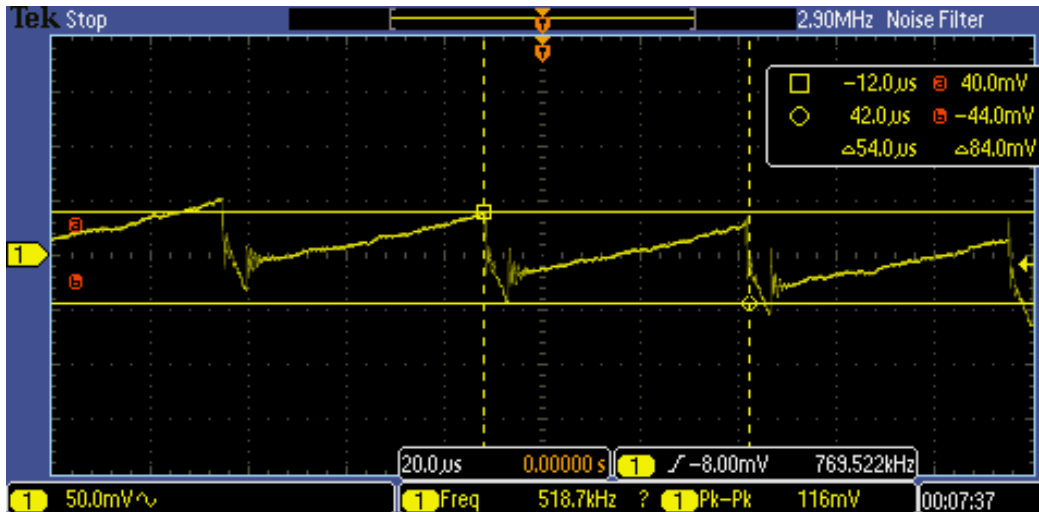

Picture 3: 15-20 kHz Ripple Component of V_{out}

16. While connected to V_{out} , use the FFT scope feature to determine the magnitude (in V_{rms}) of the 120 Hz and 15-20 kHz components. Compare your rms readings to the triangle-wave assumption rms calculations of the previous two steps. How large is the 15-20 kHz component compared to the 120 Hz component? (Note: With a wide span in the kHz range, you may not have enough resolution to place your vertical cursor exactly on 120 Hz. Thus, get as close as possible. What's most important is the magnitude measurement of the 120 Hz peak.)

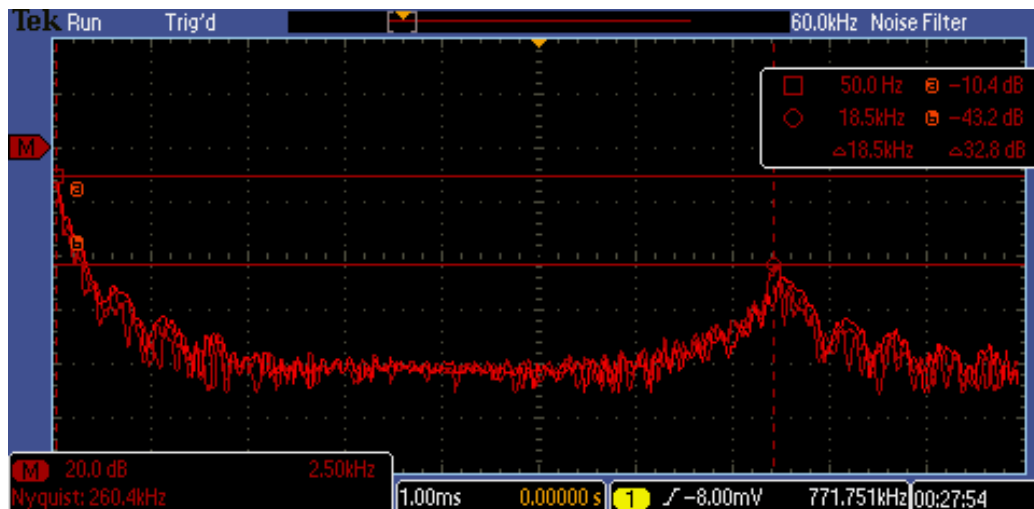

Save screen
snapshot #2

Picture 4: Fourier Transform (5Ω Load, $D = 0.90$, $f = 15\text{-}20$ kHz)
(db Values of 120 Hz and 18.5 kHz Components Shown)

17. Next, move the oscilloscope probe to view V_{DS} . Measure the peak value of V_{DS} for the following two cases:
- without ripple current capacitor, and
 - with ripple current capacitor.

EE462L, Power Electronics, DC-DC Buck Converter
Version February 8, 2014

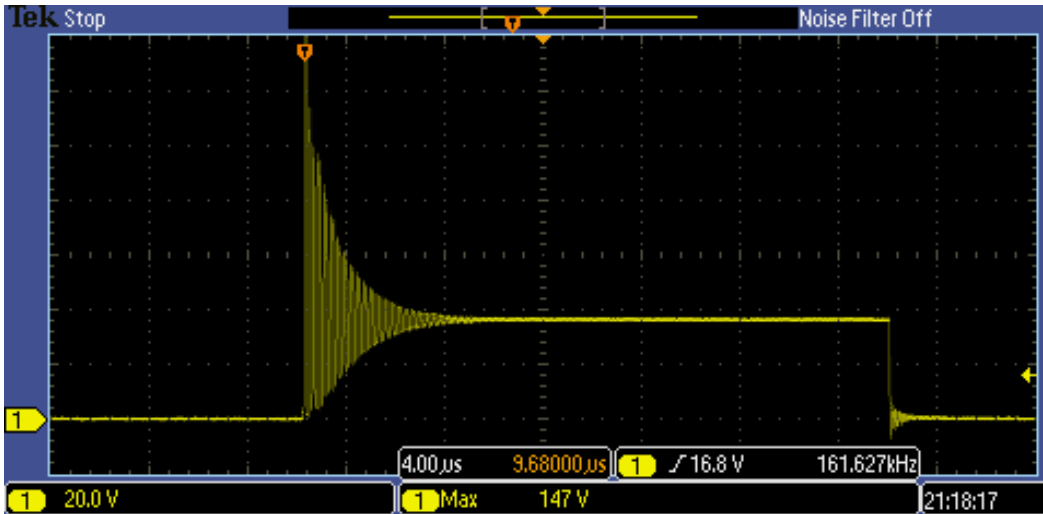

Picture 5: Case A - V_{DS} without Input Ripple Current Capacitor

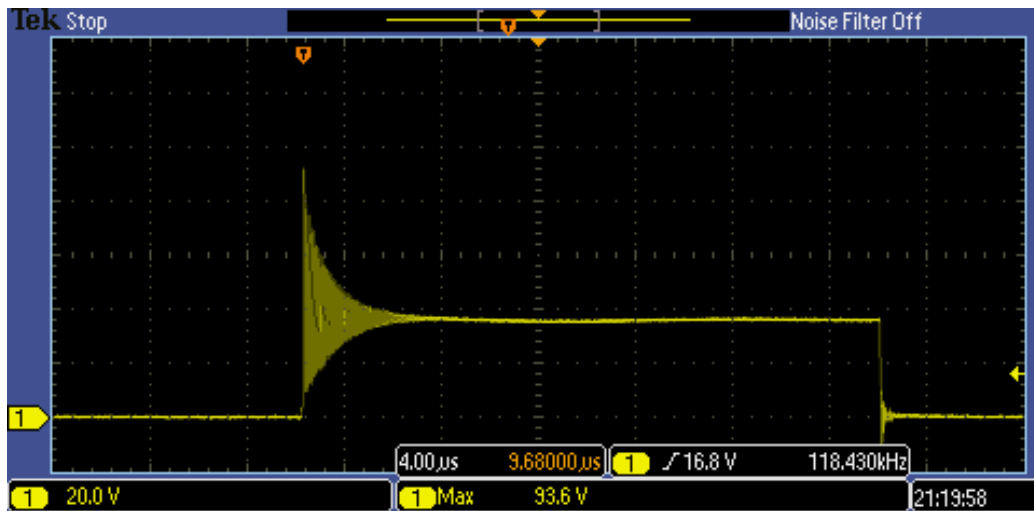

Save screen
snapshot #3

Picture 6: Case B - V_{DS} with Input Ripple Current Capacitor

18. Move the oscilloscope probe to view the voltage across the inductor (i.e., V_L). Lower D until the onset of discontinuous conduction (denoted by the appearance of a “low frequency” parasitic oscillation in the inductor voltage due to the interaction of L with MOSFET and diode capacitances). Record the values of D , f , V_{in} , I_{in} , V_{out} , and I_{out} at the continuous/discontinuous boundary, and save a screen snapshot that shows the oscillation during discontinuous conduction. Substitute the values into (9) and calculate L . Compare the calculated L to the actual L used in the circuit.

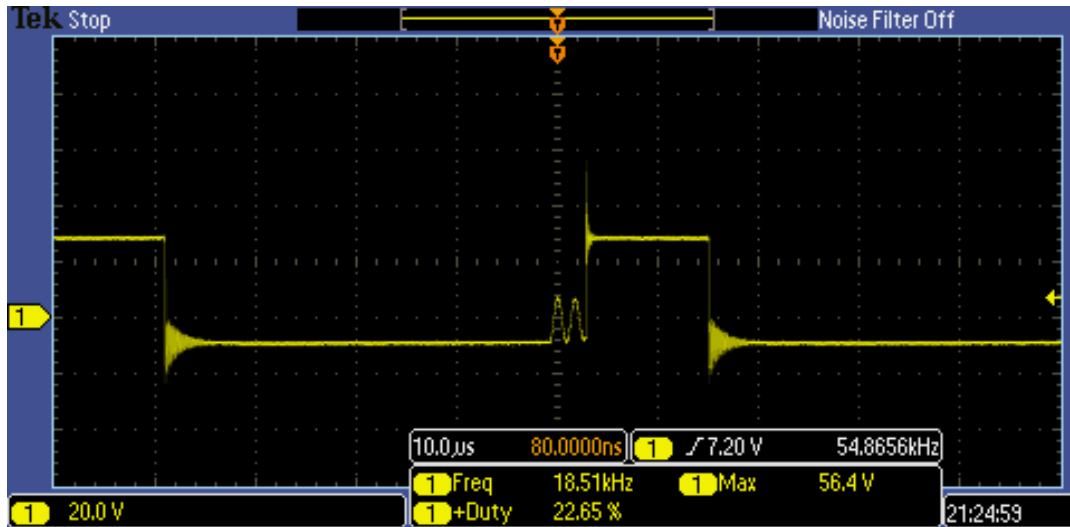

Save screen
snapshot #4

Picture 7: V_L during Discontinuous Conduction

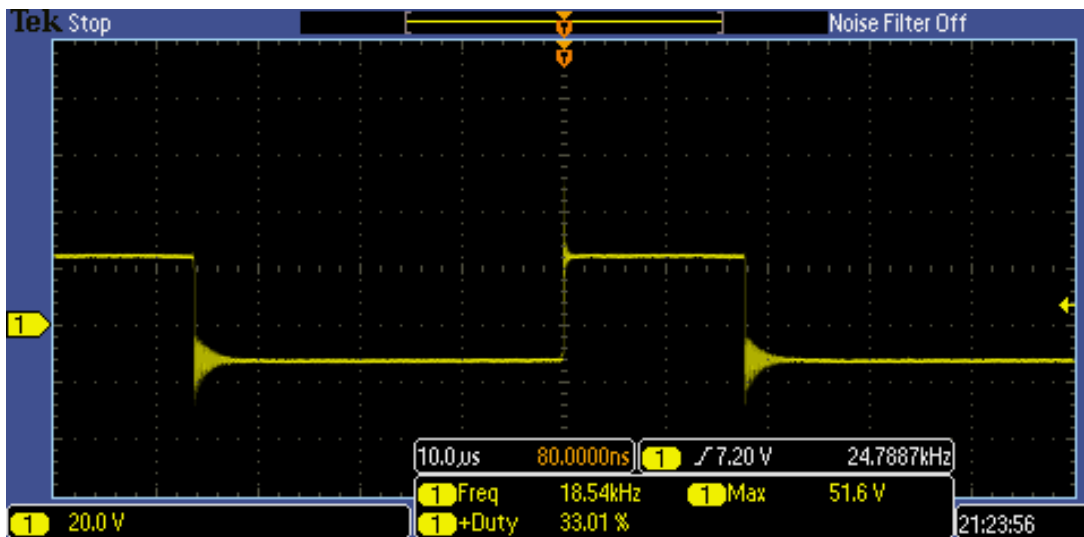

Picture 8: V_L at the Conduction/Discontinuous Boundary

5 Parts List

- 200 V, 16 A ultrafast rectifier (Fairchild Semiconductor FES16DT, Mouser #512-FES16DT).
- Heat sinks for diode and inductor, approx. 1.5" x 1.75" for TO-220 case style, 9.6 °C/W (Aavid Thermalloy, Mouser #532-507222B00)
- Output cap is 1500 – 2200 μ F, 200 V – 250 V, 5 Arms ripple current, electrolytic. (Panasonic #ECE-T2EP152EA, 1500 μ F, 250 V, 5.66 Arms ripple at 10 kHz-50 kHz, Digikey #P10048-ND). **Be careful with polarity.**
- Inductor is 100 μ H, 9 A (J. W. Miller RF Choke, Model 1130-101K-RC, Newark #63K3321 or Mouser #542-1130-101K-RC)
- #4-40 x 1" flat slotted nylon screw and lock nut (Eagle Plastics, Mouser #561-J440-1 and #561-H440, respectively) for mounting the inductor
- One 0.01 Ω current sensing shunt resistor (for measuring output current) (in student parts bin).
- 10 μ F high-frequency bipolar capacitor (50 V, 10 A peak-to-peak ripple current, Xicon #140-BPHR50V10-RC, Mouser #140-BPHR50V10-RC). **This capacitor is not polarized.**
- Five two-terminal, 30 A terminal blocks
- Steel corner brackets (1½" for filter capacitor, and 1½" for diode and its heat sink, holes not enlarged).
- 8" nylon cable tie (Eagle Plastics #481-0115, Mouser # 481-0115) (in student parts bin)
- 1" by 6" wood, 10" long piece

Extra parts

For the student parts bin and screw cabinet, at least

- 5 of the 250 V MOSFETs (individually bagged)
- 5 of the 200 V, 16 A ultrafast rectifiers
- 5 of the dc jacks
- 5 of the 10 k Ω audio taper and linear taper potentiometers
- 5 of the PWM modulator chips
- 5 of the inverting driver chips
- 5 of the 14-pin sockets
- 5 of the 8-pin DIP sockets
- 5 of the green plugs
- 10 of the #4-40 x 1" flat slotted nylon screws and lock nuts

Plastic bags for parts

- 6"x6", 4mil for small parts
- 6"x8", 6mil for holding everything