

Stability and Control of dc Micro-grids

Alexis Kwasinski

Thank you to Mr. Chimaobi N. Onwuchekwa
(who has been working on boundary controllers)

May, 2011

Overview

- Introduction
- Constant-power-load (CPL) characteristics and effects
- Dynamical characteristics of DC micro-grids
- Conclusions/future work

Micro-grids

- What is a micro (or nano) grid?
 - Micro-grids are independently controlled (small) electric networks, powered by local units (distributed generation).

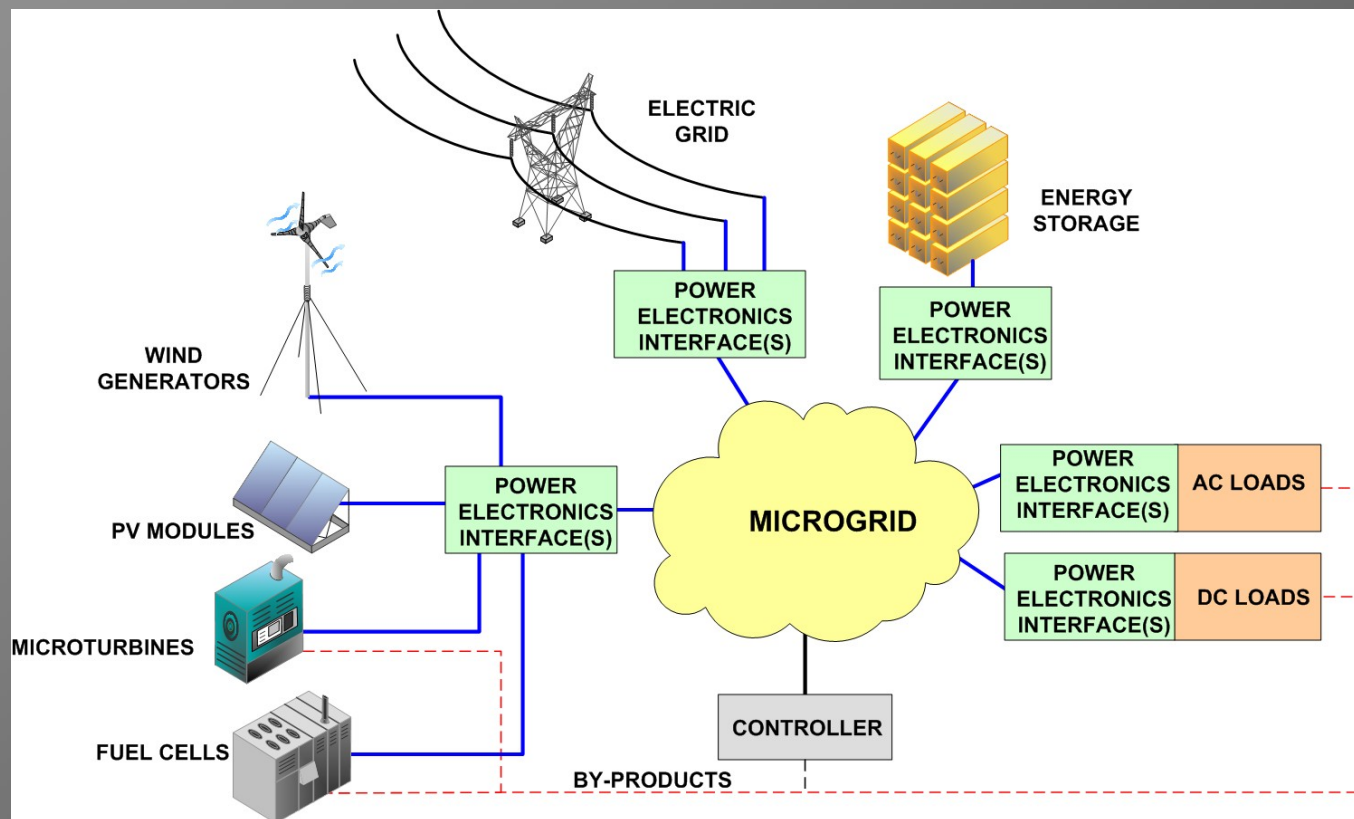

Introduction

- ac vs. dc micro-grids
 - Some of the issues with Edison's dc system:
 - Voltage-transformation complexities
 - Incompatibility with induction (AC) motors
 - Power electronics help to overcome difficulties
 - Also introduces other benefits – DC micro-grids
 - DC micro-grids
 - Help eliminate long AC transmission and distribution paths
 - Most modern loads are DC – modernized conventional loads too!
 - No need for frequency and phase control – stability issues?

Introduction

- ac vs. dc micro-grids

- DC is better suited for energy storage, renewable and alternative power sources

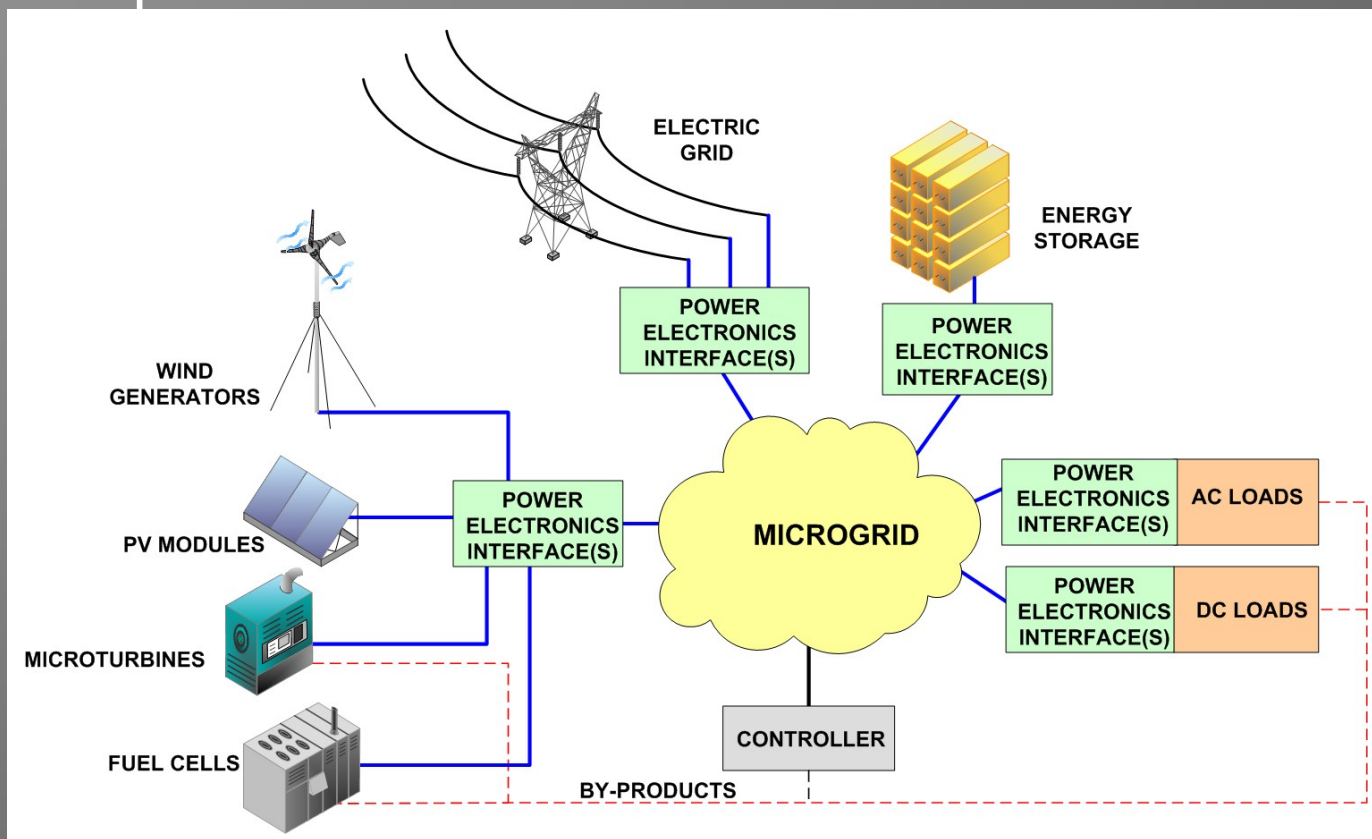

Constant-power loads

- Characteristics

- DC micro-grids comprise cascade distributed power architectures – converters act as interfaces
- Point-of-load converters present constant-power-load (CPL) characteristics

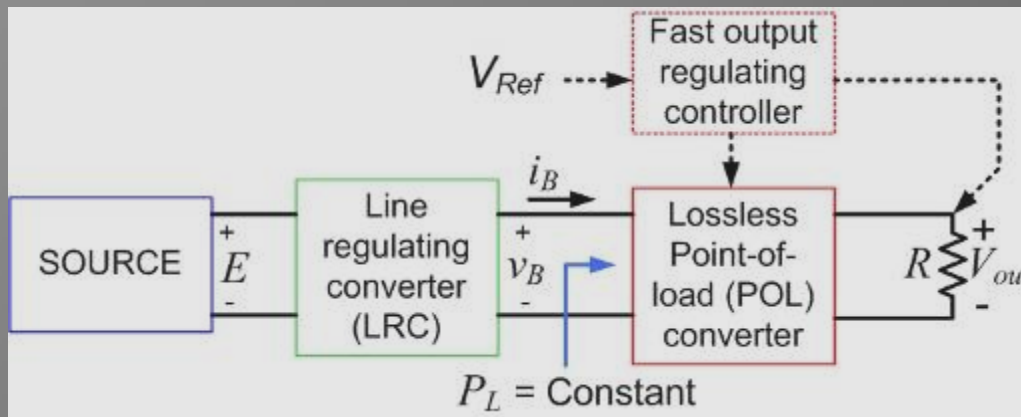

$$i(t) = \begin{cases} 0 & \text{if } v(t) < V_{\text{lim}} \\ \frac{P_L}{v(t)} & \text{if } v(t) > V_{\text{lim}} \end{cases}$$

$$\delta Z = \frac{dv_B}{di_B} = -\frac{P_L}{i_B^2}$$

- CPLs introduce a destabilizing effect

Constant-power loads

- Characteristics

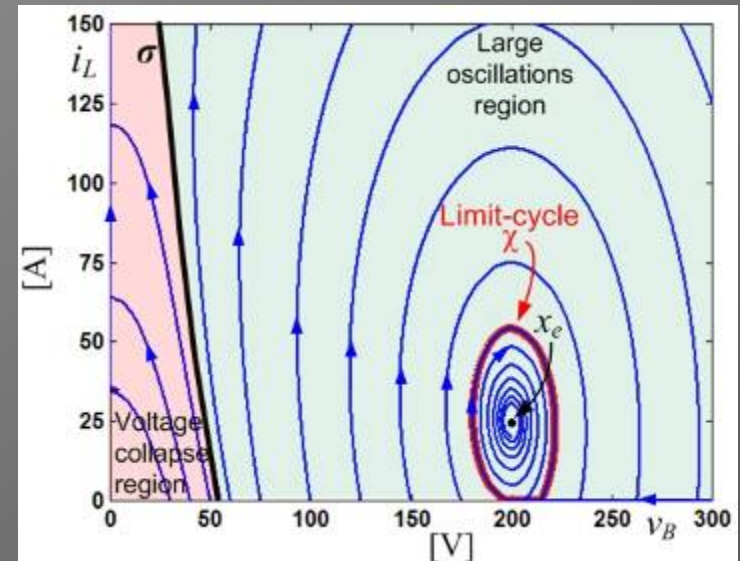
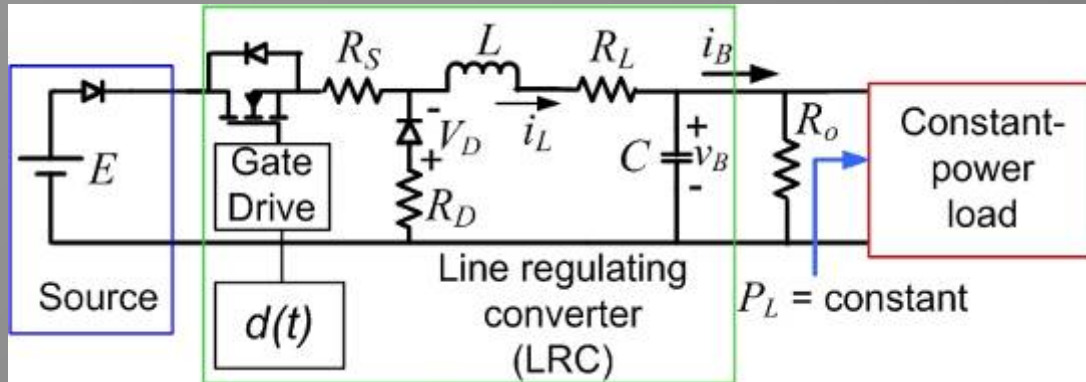

Simplified cascade distributed power architecture with a buck LRC.

$$\begin{cases} L \frac{di_L}{dt} = q(t)(E - R_S i_L) - (1 - q(t))(V_D + i_L R_D) - i_L R_L - v_C \\ C \frac{dv_C}{dt} = i_L - \frac{P_L}{v_C} - \frac{v_C}{R_o} \end{cases}$$

with $i_L \geq 0, v_C > \varepsilon$

- Constraints on state variables makes it extremely difficult to find a closed form solution, but they are essential to yield the limit cycle behavior.

Constant-power loads

• Characteristics

- The steady state fast average model yields some insights:

$$LC \frac{d^2 x_2}{dt^2} - \frac{LP_L}{x_2^2} \frac{dx_2}{dt} + x_2 = DE$$

$$\text{with } x_2 > \varepsilon \text{ and } x_1 = C \frac{dx_2}{dt} + \frac{P_L}{x_2} \geq 0$$

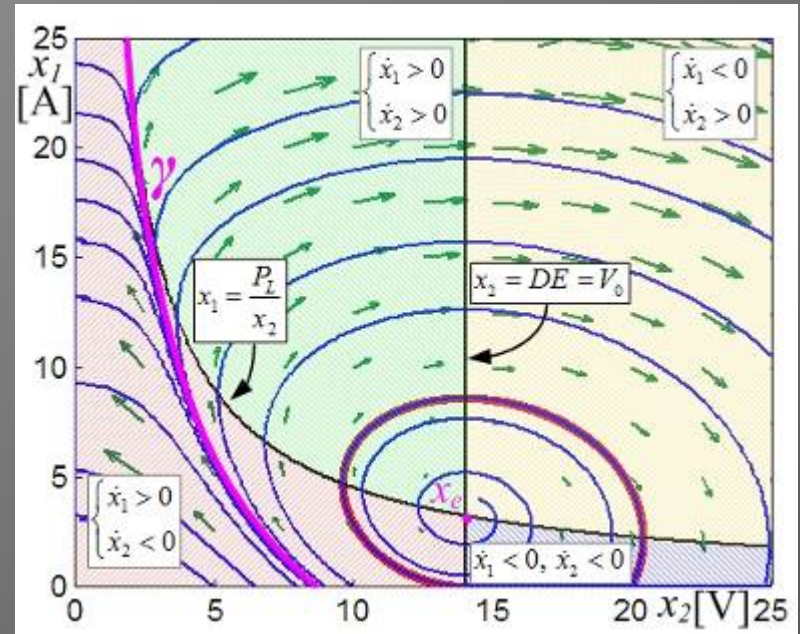

- Lack of resistive coefficient in first-order term
- Unwanted dynamics introduced by the second-order term can not be damped.

- Necessary condition for limit cycle behavior: $\frac{d(t)E - v_C}{L} > \frac{1}{C} \left(\frac{P_L}{v_C} - i_L \right) \frac{P_L}{v_C^2}$

- Note: $x_1 = i_L$ and $x_2 = v_C$

Constant-power loads

- Characteristics

- Large oscillations may be observed not only when operating converters in open loop but also when they are regulated with most conventional controllers, such as PI controllers.

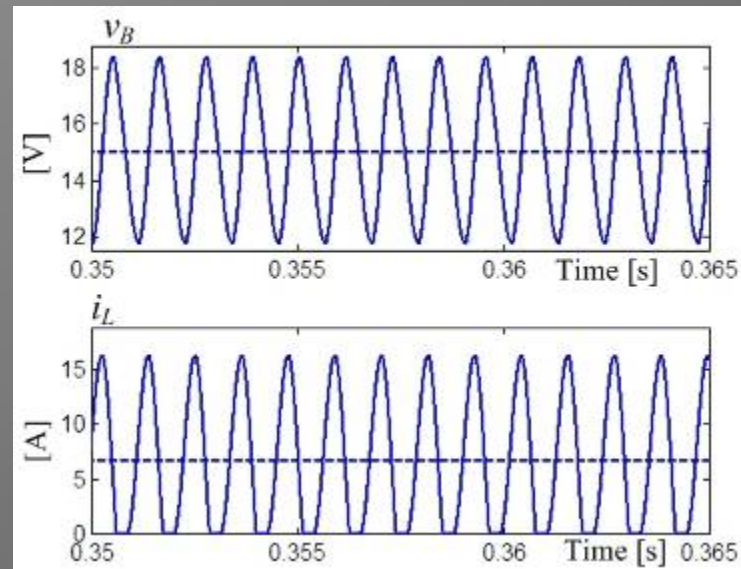

Simulation results for an ideal buck converter with a PI controller both for a 100 W CPL (continuous trace) and a 2.25Ω resistor (dashed trace); $E = 24 \text{ V}$, $L = 0.2 \text{ mH}$, $PL = 100 \text{ W}$, $C = 470 \mu\text{F}$.

Controls

- Characteristics

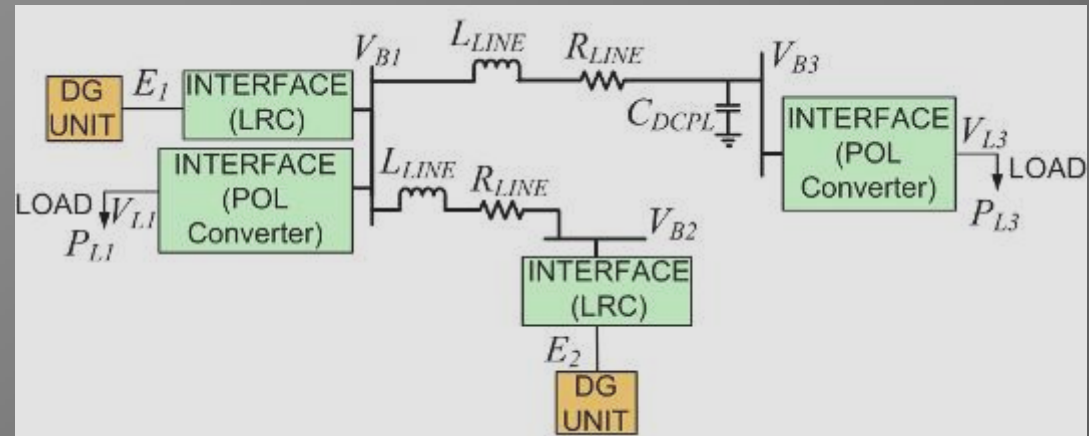
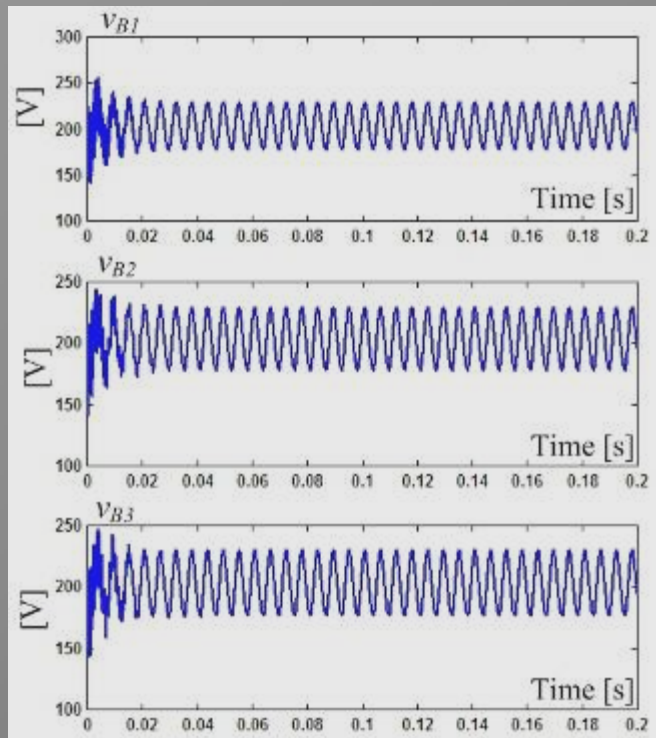

$$E_1 = 400V, E_2 = 450V, P_{L1} = 5kW, P_{L2} = 10kW, \\ L_{LINE} = 5\mu H, R_{LINE} = 10m\Omega, C_{DCPL} = 1mF$$

LRC parameters:

$$L = 0.5mH, C = 1mF, D_1 = 0.5, D_2 = 0.54, R_L = 0.8\Omega$$

- Large oscillations and/or voltage collapse are observed due to constant-power loads in micro-grids without proper controls

Stabilization

- Passive methods – added resistive loads

- Linearized equation: $\lambda^2 + \lambda \left(\frac{R_i}{L} - \frac{P_L}{CV_o^2} + \frac{1}{R_o C} \right) + \frac{R_i}{L} \left(\frac{1}{R_o C} - \frac{P_L}{CV_o^2} \right) + \frac{1}{LC} = 0$

- Conditions:

$$P_L < V_o^2 \left(\frac{C}{L} R_i + \frac{1}{R_o} \right), P_L < V_o^2 \left(\frac{1}{R_i} + \frac{1}{R_o} \right)$$

where $R_i = R_S D + R_D (1 - D) + R_L$

- Issue: Inefficient solution

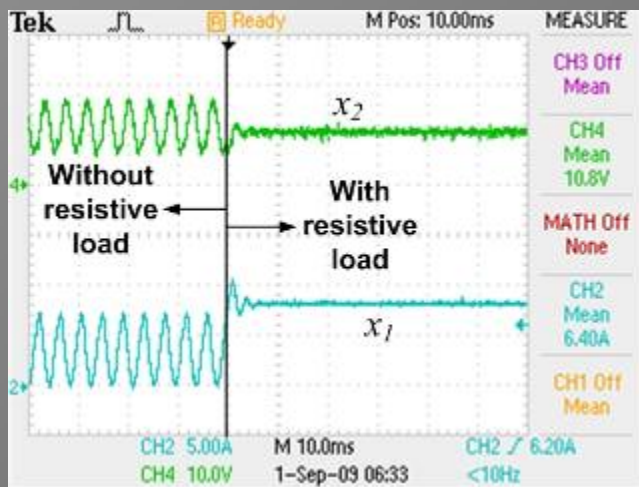

1Ω resistor R_o in parallel to C_{DCPL}

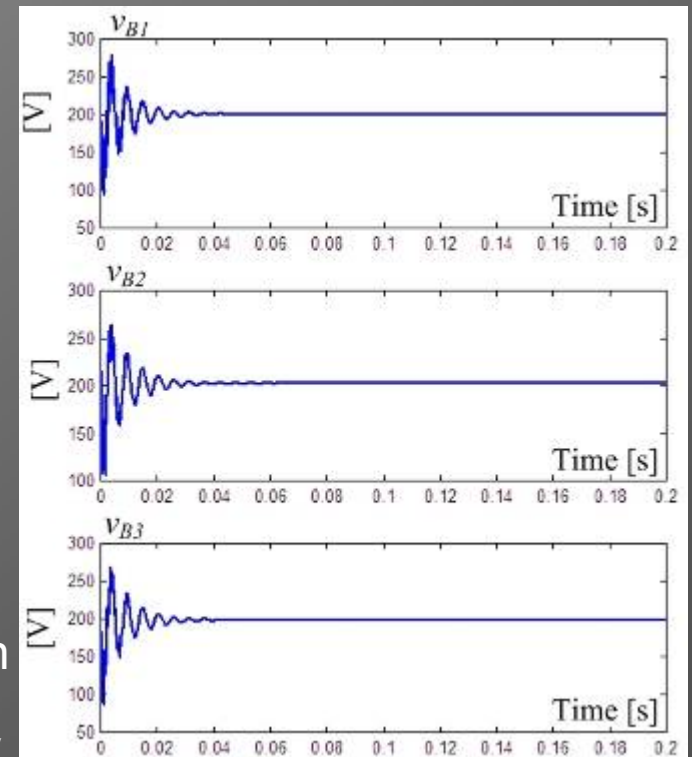

$E = 12.5V, L = 480\mu H, C = 480\mu F, R_o = 2\Omega, D = 0.9, P_L = 43.8W$

Stabilization

- Passive methods – added capacitance

- Condition: $C > \frac{P_L L}{V_o^2 R_i}$

- Issues: Bulky, expensive and may reduce reliability. But may improve fault detection and clearance

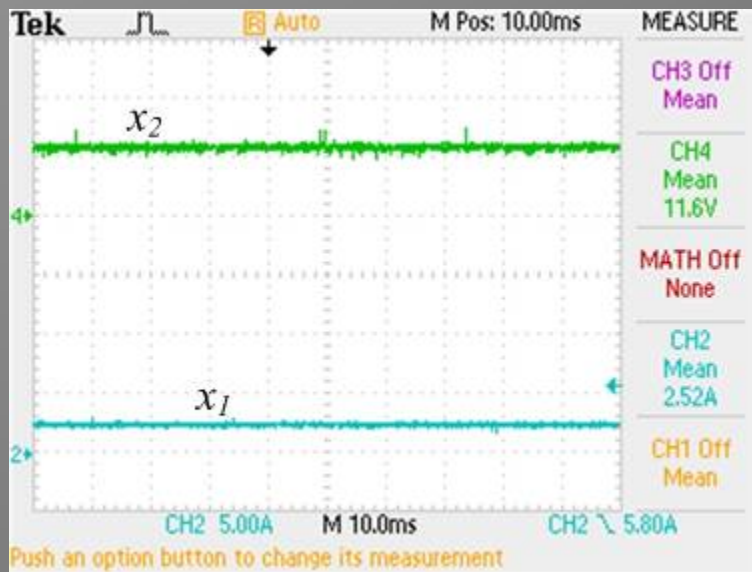

$E = 12.5V, L = 480\mu H, C = 480\mu F + 200mF,$
 $D = 0.9, P_L = 35W$

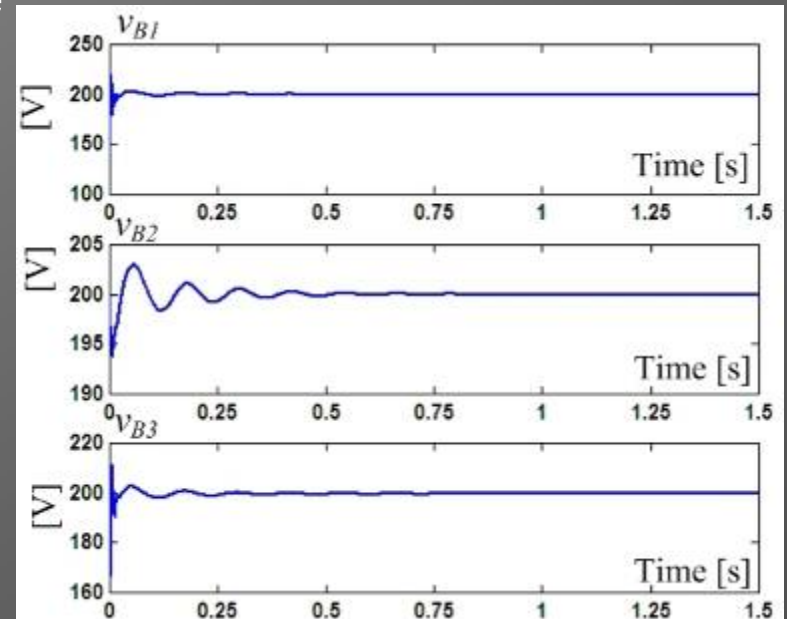

60 mF added in parallel to C_{DCPL}

Stabilization

- Passive methods – added bulk energy storage
 - It can be considered an extension of the previous approach.
 - Energy storage needs to be directly connected to the main bus without intermediate power conversion interfaces.
 - Issues: Expensive, it usually requires a power electronic interface, batteries and ultracapacitors may have cell voltage equalization problems, and reliability, operation and safety may be compromised.

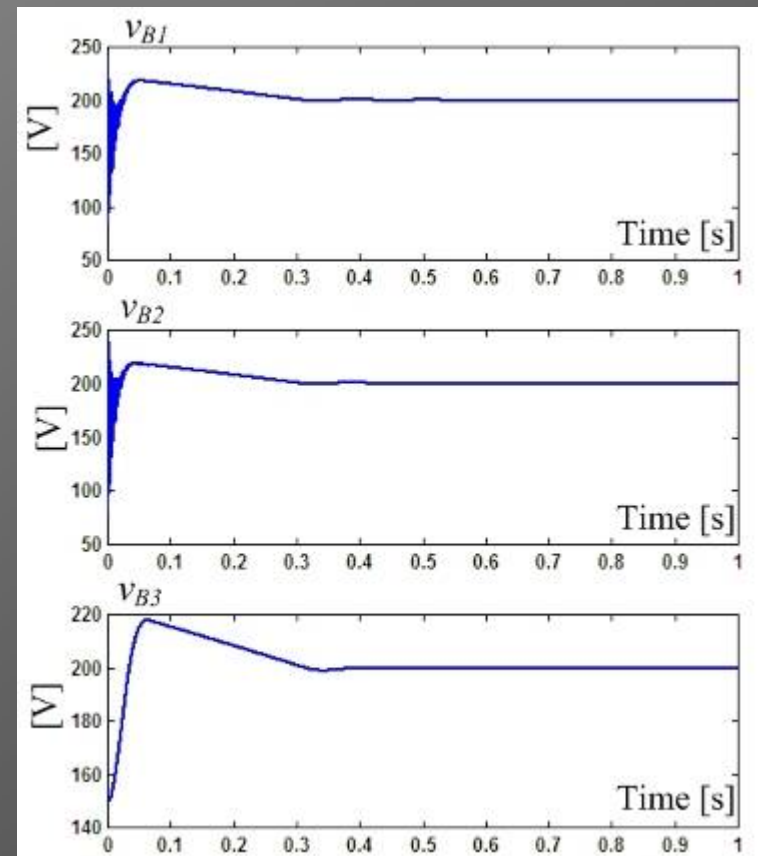

Stabilization

- Passive methods – load shedding

- It is also based on the condition that: $C > \frac{P_L L}{V_o^2 R_i}$

- Issues: Not practical for critical loads

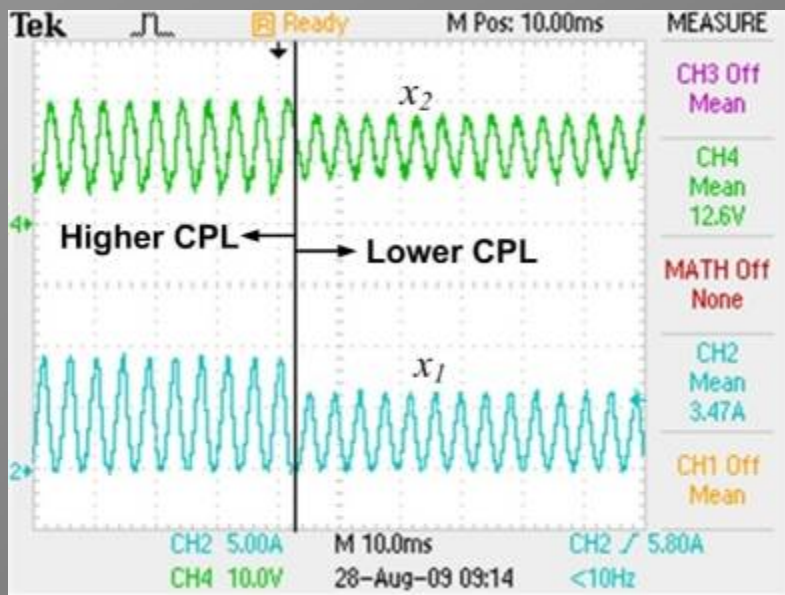

Load reduced from 49 W to 35 W

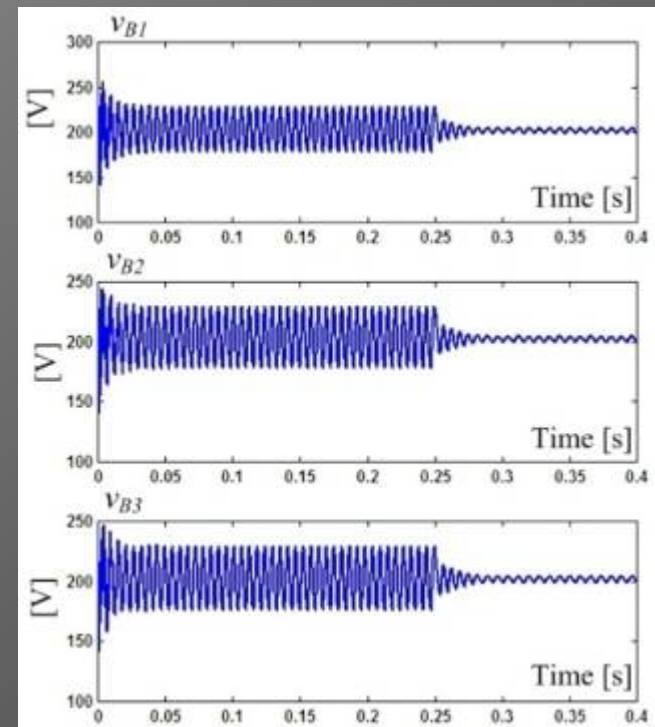

Load dropped from 10 to 2.5 kW at 0.25 seconds

Stabilization

- Linear controllers – Passivity based analysis
- Initial notions

A system

$$\Sigma : \begin{cases} \dot{x} = f(x, u), & x(0) = x_0 \in \mathbb{R}^n, f : \mathbb{R}^n \times \mathbb{R}^m \rightarrow \mathbb{R}^n \\ y = h(x, u), & h : \mathbb{R}^n \times \mathbb{R}^m \rightarrow \mathbb{R}^p \end{cases}$$

with

f is locally Lipschitz

and

$$f(0,0) = h(0,0) = 0$$

is passive if there exists a continuously differentiable positive definite function $H(x)$ (called the storage function) such that

$$\dot{H}(x) = \frac{dH}{dx} f(x, u) \leq u^T y \quad \forall (x, u) \in \mathbb{R}^n \times \mathbb{R}^m$$

Stabilization

- **Linear controllers – Passivity based analysis**

- Initial notions

- Σ is output strictly passive if:

$$\dot{H}(x) = \frac{dH}{dx} f(x,u) \leq u^T y - \delta_o \|y\|^2 \quad \forall (x,u) \in \mathbb{R}^n \times \mathbb{R}^m, \text{ and } \delta_o > 0$$

- A state-space system $\dot{x} = f(x)$, $x \in \mathbb{R}^n$ is zero-state observable from the output $y=h(x)$, if for all initial conditions $x(0) \in \mathbb{R}^n$ we have $y(t) \equiv 0 \Rightarrow x(t) \equiv 0$

- Consider the system Σ . The origin of $f(x,0)$ is asymptotically stable (A.S.) if the system is

- strictly passive, or

- output strictly passive and zero-state observable.

- If $H(x)$ is radially unbounded the origin of $f(x,0)$ is globally asymptotically stable (A.S.)

- In some problems $H(x)$ can be associated with the Lyapunov function.

Stabilization

- **Linear controllers – Passivity based analysis**

- Consider a buck converter with ideal components and in continuous conduction mode. In an average sense and steady state it can be represented by

$$\mathbf{M}\dot{x} + [\mathbf{J} + \mathbf{R}(x)]x = d\mathbf{E}$$

where

$$\mathbf{M} = \begin{pmatrix} L & 0 \\ 0 & C \end{pmatrix} \quad \mathbf{J} = \begin{pmatrix} 0 & 1 \\ -1 & 0 \end{pmatrix} \quad \mathbf{R}(x) = \begin{pmatrix} 0 & 0 \\ 0 & \frac{P_L}{x_2^2} \end{pmatrix} \quad \mathbf{E} = \begin{pmatrix} E \\ 0 \end{pmatrix} \quad x = \begin{pmatrix} x_1 \\ x_2 \end{pmatrix}$$

$$\text{Equilibrium point: } x_e = \begin{pmatrix} I_L \\ V_o \end{pmatrix} = \begin{pmatrix} \frac{P_L}{DE} \\ DE \end{pmatrix}$$

$$\mathbf{M}\dot{x} + [\mathbf{J} + \mathbf{R}(x)]x = d\mathbf{E}$$

$$\downarrow x = \tilde{x} + x_e \text{ (Coordinate change)}$$

$$\mathbf{M}\dot{\tilde{x}} + [\mathbf{J} + \mathbf{R}(x)]\tilde{x} = d\mathbf{E} - [\mathbf{J} + \mathbf{R}(x)]x_e \quad (1)$$

Stabilization

- Linear controllers – Passivity based analysis

- Define the positive definite damping injection matrix \mathbf{R}_i as

$$\mathbf{R}_i = \begin{pmatrix} R_{i1} & 0 \\ 0 & \frac{1}{R_{i2}} - \frac{P_L}{x_2^2} \end{pmatrix}$$

\mathbf{R}_i is positive definite if $\frac{1}{R_{i2}} > \frac{P_L}{x_2^2}$. Then, $\mathbf{R}_t = \mathbf{R} + \mathbf{R}_i = \begin{pmatrix} R_{i1} & 0 \\ 0 & \frac{1}{R_{i2}} \end{pmatrix}$

From (1), add $\mathbf{R}_i(x)\tilde{x}$ on both sides:

$$\mathbf{M}\dot{\tilde{x}} + [\mathbf{J} + \mathbf{R}_t]\tilde{x} = \underbrace{d\mathbf{E} - [\mathbf{J} + \mathbf{R}(x)]x_e + \mathbf{R}_i(x)\tilde{x}}_{\tilde{\mathbf{E}} = 0 \text{ (Equivalent free evolving system)}}$$

$$\tilde{\Sigma}: \quad \mathbf{M}\dot{\tilde{x}} + [\mathbf{J} + \mathbf{R}_t]\tilde{x} = 0$$

Stabilization

- Linear controllers – Passivity based analysis
 - Consider the storage function

$$\tilde{\mathbf{H}}(x) = \frac{1}{2} \tilde{x}^T \mathbf{M} \tilde{x}$$

Its time derivative is:

$$\dot{\tilde{\mathbf{H}}}(x) = \tilde{x}^T \mathbf{M} \dot{\tilde{x}} = -\tilde{x}^T [\mathbf{J} + \mathbf{R}_t] \tilde{x} = -\tilde{x}^T \mathbf{R}_t \tilde{x} \leq 0$$

↓ if $\tilde{y} = \tilde{x}$

$$\dot{\tilde{\mathbf{H}}}(x) = -\tilde{y}^T \mathbf{R}_t \tilde{y} < \delta_o \|\tilde{y}\|^2, \quad \text{where } \delta_o = \max\left(R_{i1}, \frac{1}{R_{i2}}\right)$$

- $\tilde{\Sigma}$ is a free-evolving output strictly passive and zero-state observable system. Therefore, $\tilde{x} = 0$ is an asymptotically stable equilibrium point of the closed-loop system.

Stabilization

- Linear controllers – Passivity based analysis

- Since $\tilde{\mathbf{E}} = d\mathbf{E} - [\mathbf{J} + \mathbf{R}(\tilde{x})]x_e + \mathbf{R}_i(\tilde{x})\tilde{x} = 0$

then,
$$\begin{cases} dE - V_o + R_{i1}\tilde{x}_1 = 0 \\ I_L - \frac{P_L}{x_2} + \frac{x_2}{R_{i2}} - \frac{V_o}{R_{i2}} = 0 \end{cases}$$

Hence,

$$d = \frac{1}{E}(V_o - R_{i1}(x_1 - I_L))$$

and since $x_1 = C\dot{x}_2 + \frac{P_L}{x_2}$ and $I_L = \frac{V_o}{R_{i2}} + \frac{P_L}{x_2} - \frac{x_2}{R_{i2}}$

Thus,

$$d = \frac{1}{E} \left(-R_{i1}C\dot{x}_2 - \frac{R_{i1}}{R_{i2}}x_2 + V_o + \frac{R_{i1}}{R_{i2}}V_o \right)$$

This is a PD controller
($e = V_o - x_2$)

Stabilization

- Linear controllers – Passivity based analysis

- Remarks for the buck converter:

- x_e is not A.S. because the duty cycle must be between 0 and 1
- Trajectories to the left of γ need to have $d > 1$ to maintain stability
- Using this property as the basis for the analysis it can be obtained that a necessary but not sufficient condition for stability is

$$\frac{dE - x_2}{L} > \frac{1}{C} \left(\frac{P_L}{x_2} - x_1 \right) \frac{P_L}{x_2^2}$$

- Line and load regulation can be achieved by adding an integral term but stability is not ensured

$$d = D + k_p e + k_d \dot{e} + k_i \int e dt$$

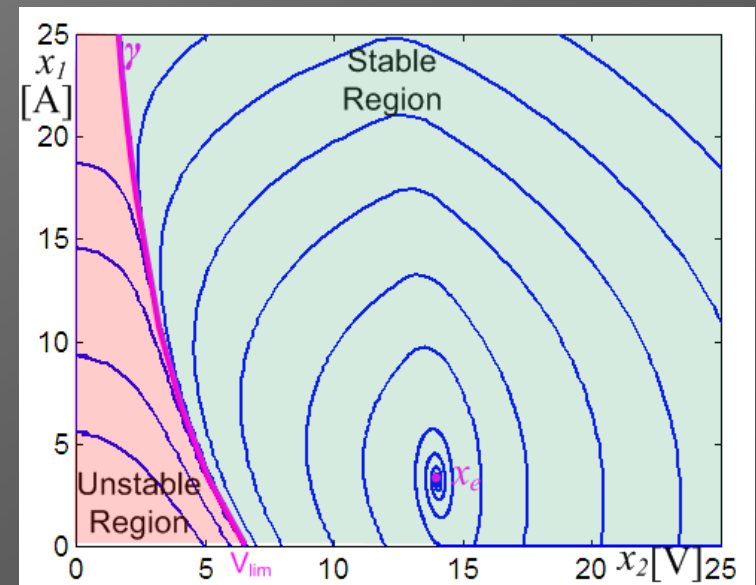

Stabilization

- Linear controllers
- Experimental results (buck converter)

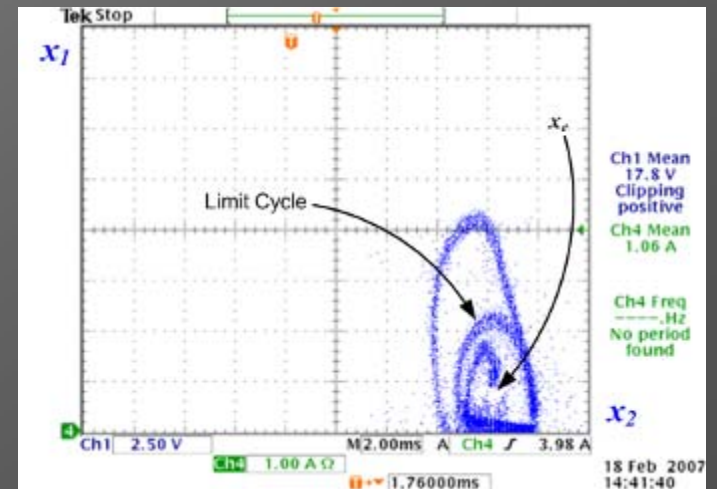
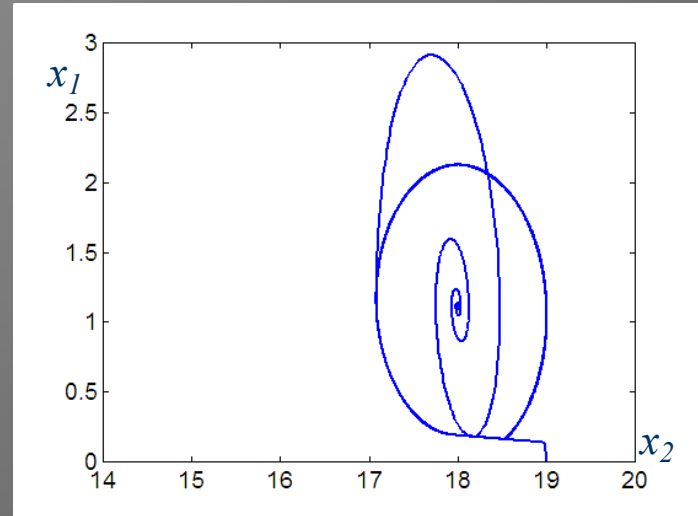
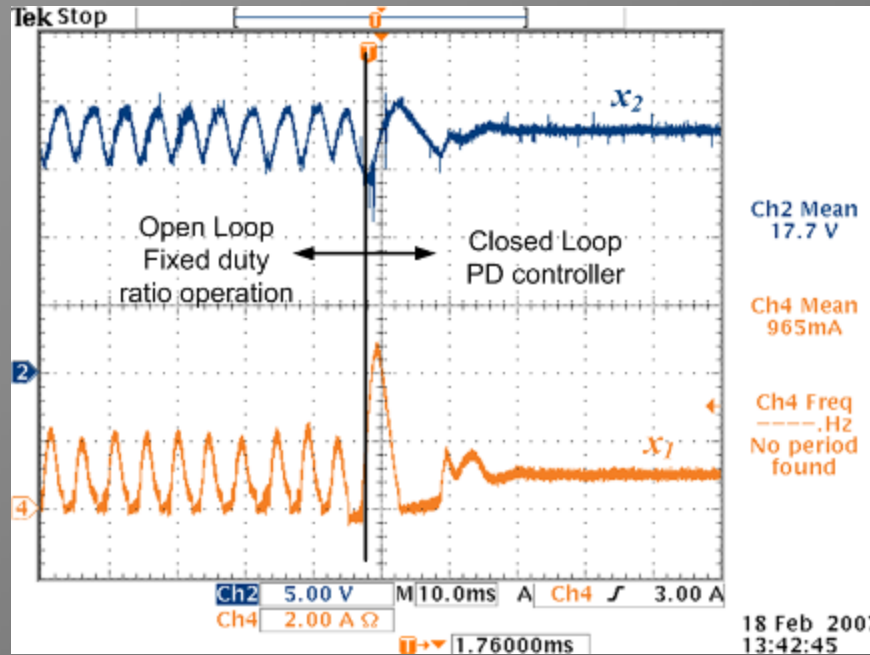

Stabilization

- Linear controllers
- Experimental results (buck converter)

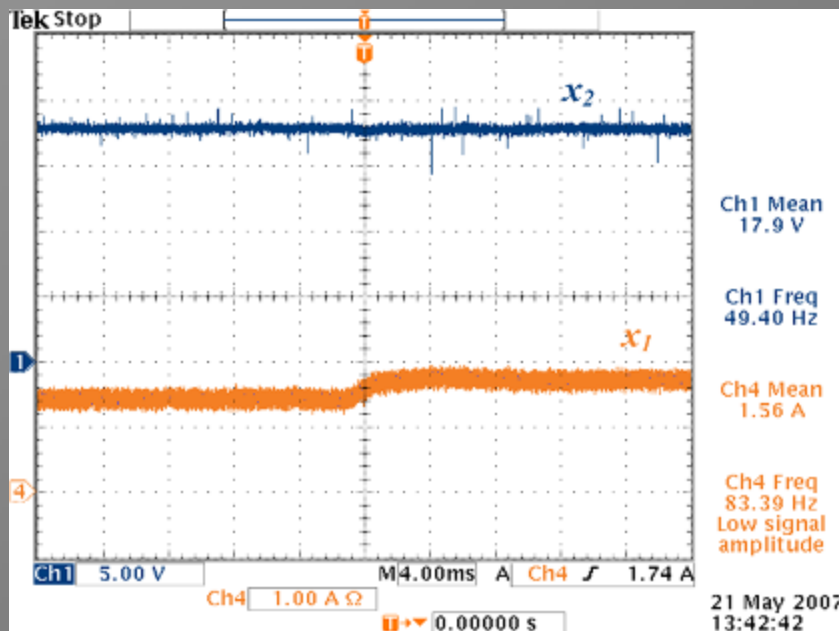

Load regulation

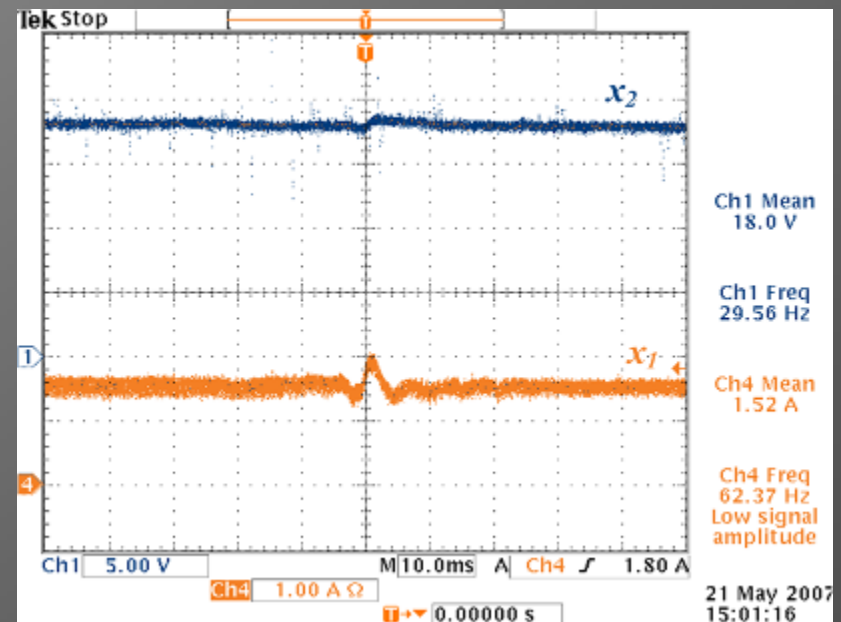

Line regulation

Stabilization

- **Linear controllers – Passivity based analysis**

- The same analysis can be performed for boost and buck-boost converters yielding, respectively

$$d' = 1 - d = \frac{D' + \sqrt{D'^2 - 4 \frac{R_{i1}}{V_0} \left(C\dot{e} + \frac{1}{R_{i2}} e \right)}}{2}, \quad d' = \frac{\frac{E}{(V_0 + E)} + \sqrt{\left(\frac{E}{V_0 + E} \right)^2 + 4 \frac{R_{i1}}{(V_0 + E)} \left(C\dot{x}_2 + \frac{x_2 - V_0}{R_{i2}} \right)}}{2}$$

- Engineering criteria dictate that the non-linear PD controller can be translated into an equivalent linear PD controller of the form:

$$\bar{d}' = k_d \dot{e} + k_p e + D'$$

- Formal analytical solution:

$$\min_{\|e\| \leq e_{\max}, \|\dot{e}\| \leq \dot{e}_{\max}} \left(\|d' - \bar{d}'(k_p, k_d)\| \right)$$

subject to

$$0 \leq 1 - d \leq d_{\max}$$

$$0 \leq 1 - \bar{d} \leq \bar{d}_{\max}$$

Stabilization

- **Linear controllers – Passivity based analysis**

- Perturbation theory can formalize the analysis (e.g. boost conv.)

- Consider

$$\tilde{\Sigma}: \quad \dot{\tilde{x}} = f(t, \tilde{x}) = -\mathbf{M}^{-1}[\mathbf{J} + \mathbf{R}_t] \tilde{x}$$

Unperturbed system with nonlinear PD controller, with

$$\mathbf{J} = \begin{pmatrix} 0 & d' \\ -d' & 0 \end{pmatrix}$$

- And

$$\tilde{\Sigma}_p: \quad \dot{\tilde{x}} = f(t, \tilde{x}) + g(t, \tilde{x}) = -\mathbf{M}^{-1}[\bar{\mathbf{J}} + \mathbf{R}_t] \tilde{x}$$

Perturbed system with linear PD controller, with

$$\bar{\mathbf{J}} = \begin{pmatrix} 0 & \bar{d}' \\ -\bar{d}' & 0 \end{pmatrix}$$

- The perturbation is

$$g(t, \tilde{x}) = \mathbf{M}^{-1}[\mathbf{J} - \bar{\mathbf{J}}] \tilde{x}$$

Stabilization

- **Linear controllers – Passivity based analysis**

- *Lemma 9.1 in Khalil's: Let $\tilde{x} = 0$ be an exponentially stable equilibrium point of the nominal system $\tilde{\Sigma}$. Let $V(t, \tilde{x})$ be a Lyapunov function of the nominal system which satisfies*

$$c_1 \|\tilde{x}\|^2 \leq V(t, \tilde{x}) \leq c_2 \|\tilde{x}\|^2$$

$$\frac{\partial V(t, \tilde{x})}{\partial t} + \frac{\partial V(t, \tilde{x})}{\partial \tilde{x}} f(t, \tilde{x}) \leq -c_3 \|\tilde{x}\|^2$$

$$\left\| \frac{\partial V(t, \tilde{x})}{\partial \tilde{x}} \right\| \leq c_4 \|\tilde{x}\|$$

- in $[0, \infty) \times D$ with c_1 to c_4 being some positive constants. Suppose the perturbation term $g(t, \tilde{x})$ satisfies*

$$\|g(t, \tilde{x})\| \leq \nu \|\tilde{x}\| \quad \forall t \geq 0, \forall \tilde{x} \in \Omega \quad \text{where } \Omega: \|\tilde{x}\| < \infty \quad \text{and } \nu < \frac{c_3}{c_4}$$

- Then, the origin is an exponentially stable equilibrium point of the perturbed system $\tilde{\Sigma}_p$.*

Stabilization

- **Linear controllers – Passivity based analysis**

- Taking $V(t, \tilde{x}) = \tilde{H}(\tilde{x})$

- It can be shown that

$$c_1 = \lambda_{\min}(\mathbf{M})$$

$$c_2 = \lambda_{\max}(\mathbf{M})$$

$$c_3 = \lambda_{\min}(2\mathbf{J} + 3\mathbf{R}_t)$$

$$c_4 = \|\mathbf{M}\| = \sqrt{\lambda_{\max}(\mathbf{M}^T \mathbf{M})} = \sqrt{\max(L^2, C^2)} = \max(L, C)$$

- Also, $\tilde{x} = 0$ is an exponentially stable equilibrium point of $\tilde{\Sigma}$, $g(t, 0) = 0$

and

$$\|g(t, \tilde{x})\| \leq \nu \|\tilde{x}\| \quad \forall t \geq 0, \forall \tilde{x} \in \Omega \quad \text{where } \Omega: \|\tilde{x}\| < \infty$$

with

$$\nu = \|\mathbf{G}\| = \max\left(\left|\frac{(\bar{d}' - d')}{L}\right|, \left|\frac{(d' - \bar{d}')}{C}\right|\right)$$

- Thus, stability is ensured if $|\bar{d}' - d'| < \frac{\lambda_{\min}(2\mathbf{J} + 3\mathbf{R}_t)}{\max\left(\frac{C}{L}, \frac{L}{C}\right)}$

Stabilization

- Linear controllers
- Experimental results boost converter

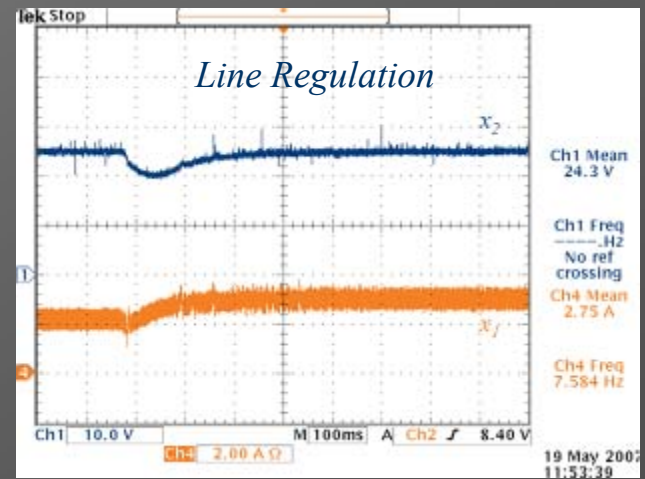
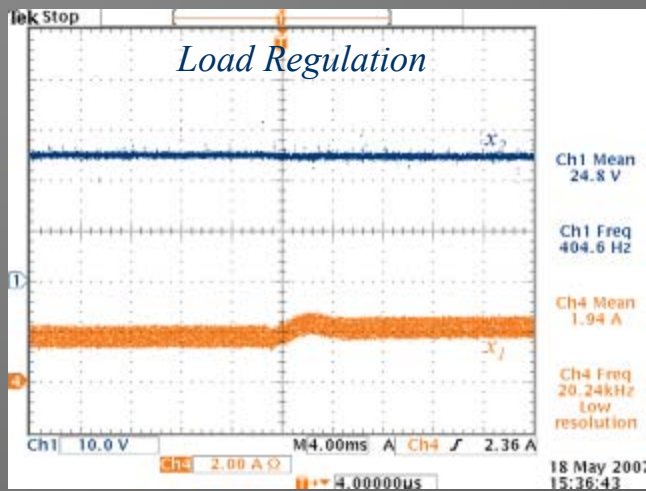
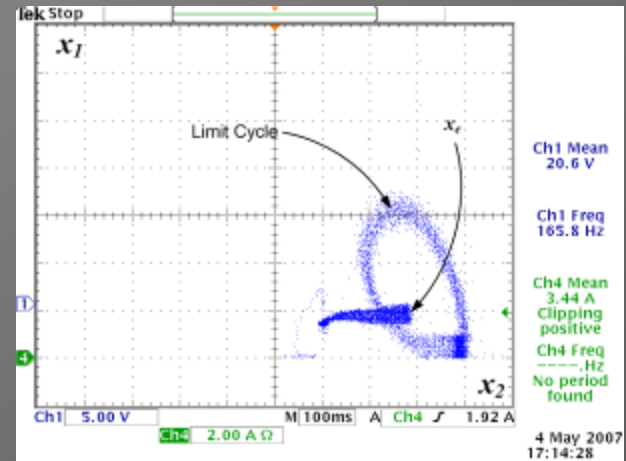
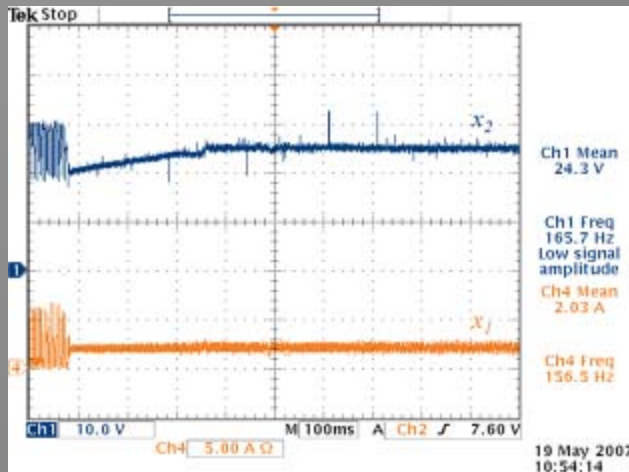

Stabilization

- Linear controllers
- Experimental results voltage step-down buck-boost converter

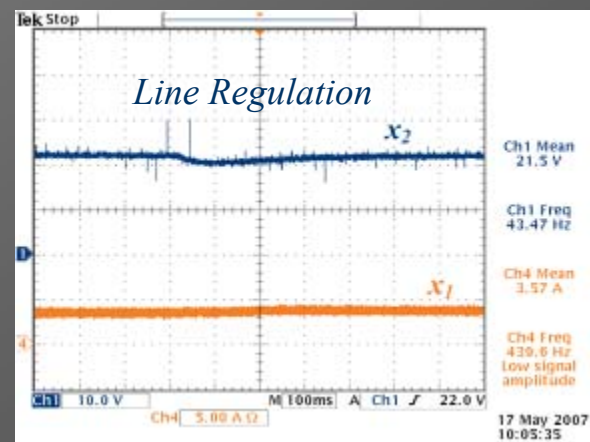
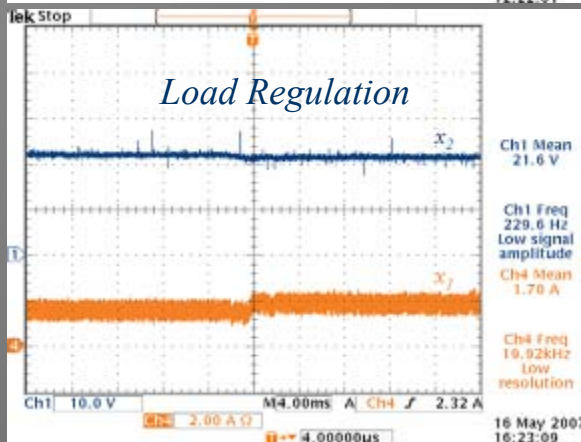
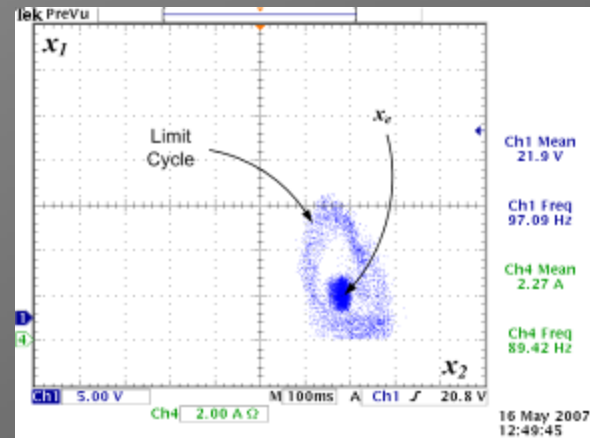
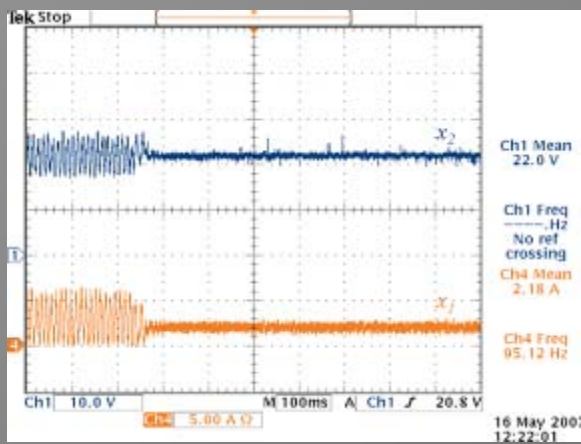

Stabilization

- Linear controllers
- Experimental results voltage step-up buck-boost converter

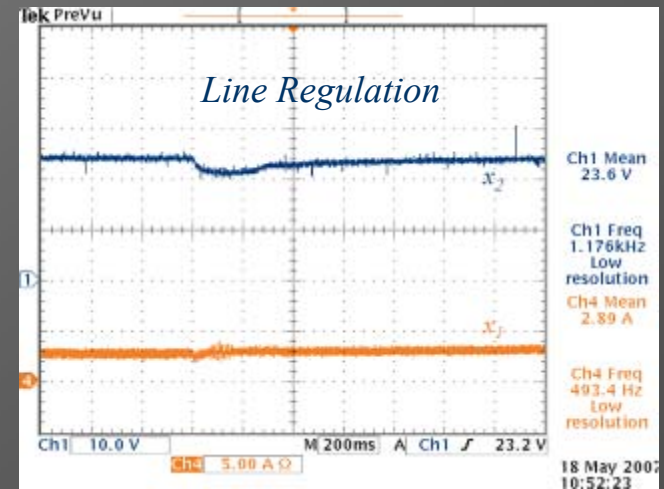
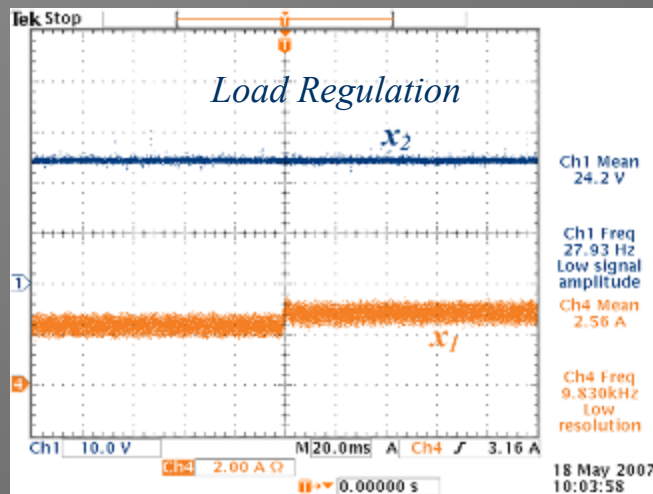
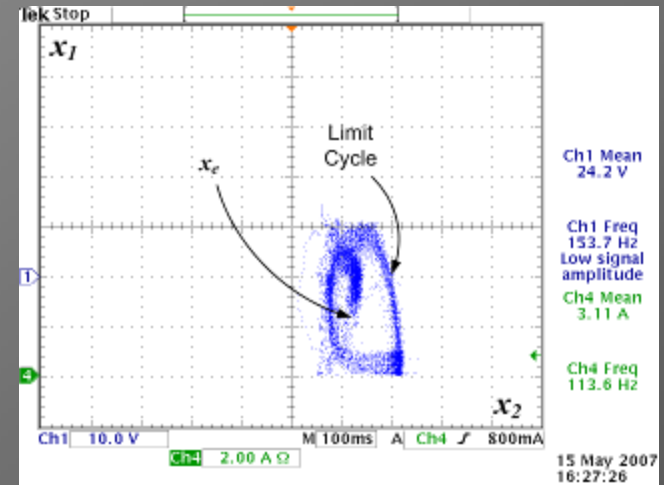
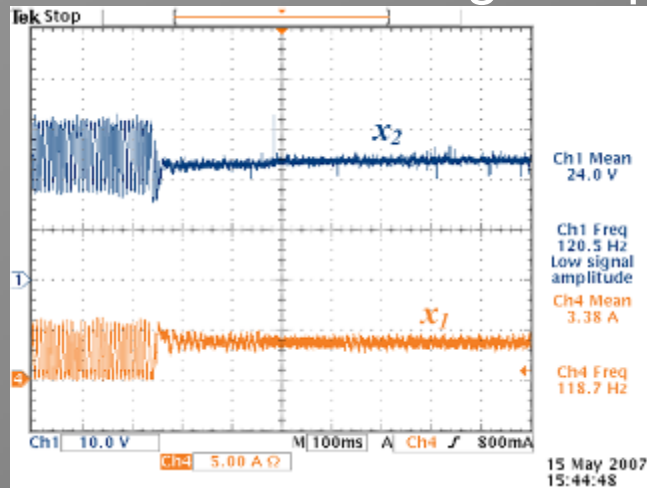

Stabilization

- Linear Controllers - passivity-based analysis
 - All converters with CPLs can be stabilized with PD controllers (adds virtual damping resistances).
 - An integral term can be added for line and load regulation
 - Issues: Noise sensitivity and slow

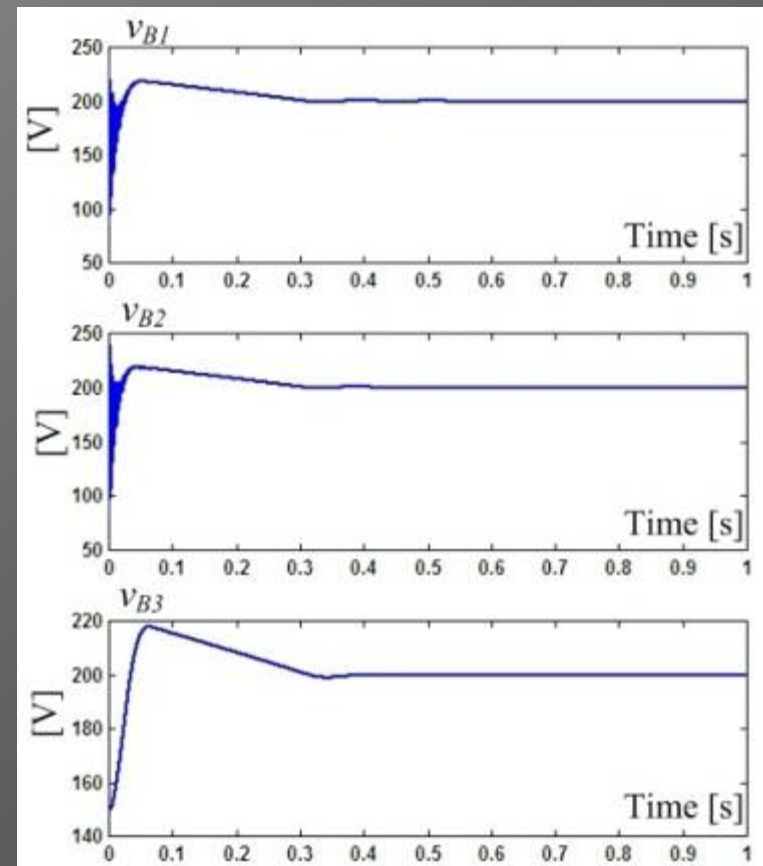
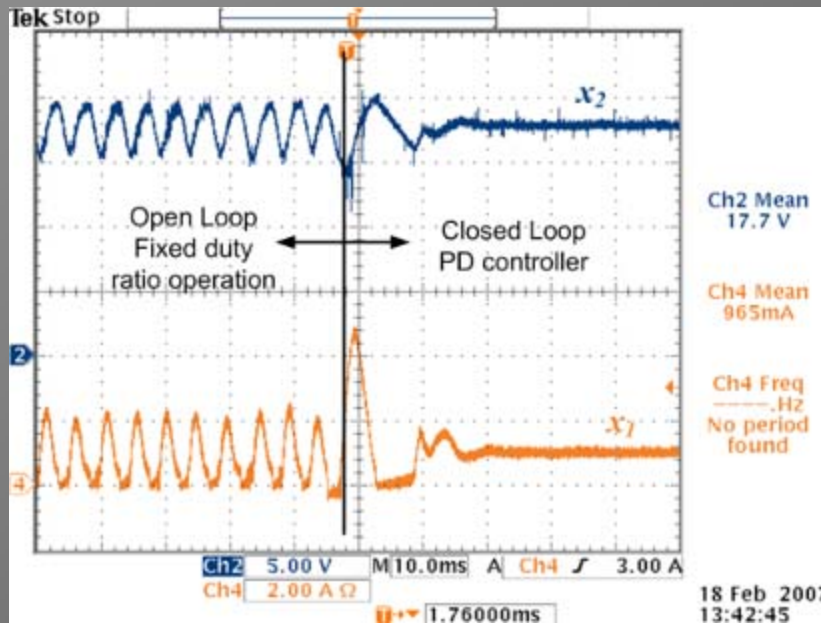

Stabilization

- **Boundary controllers**

- Boundary control: state-dependent switching ($q = q(x)$).
- Stable reflective behavior is desired.
- At the boundaries between different behavior regions trajectories are tangential to the boundary
- An hysteresis band is added to avoid chattering. This band contains the boundary.

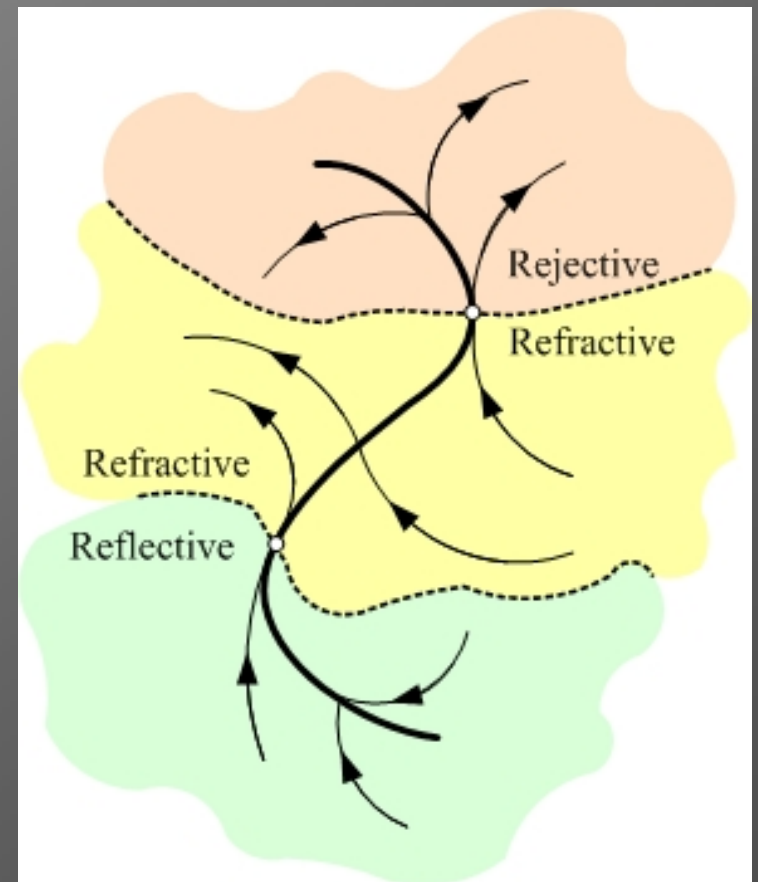

Stabilization

- Geometric controllers – 1st order boundary

- Linear switching surface with a negative slope:

$$x_1 = k(x_2 - x_{2OP}) + x_{1OP}$$

Switch is on below the boundary and off above the boundary

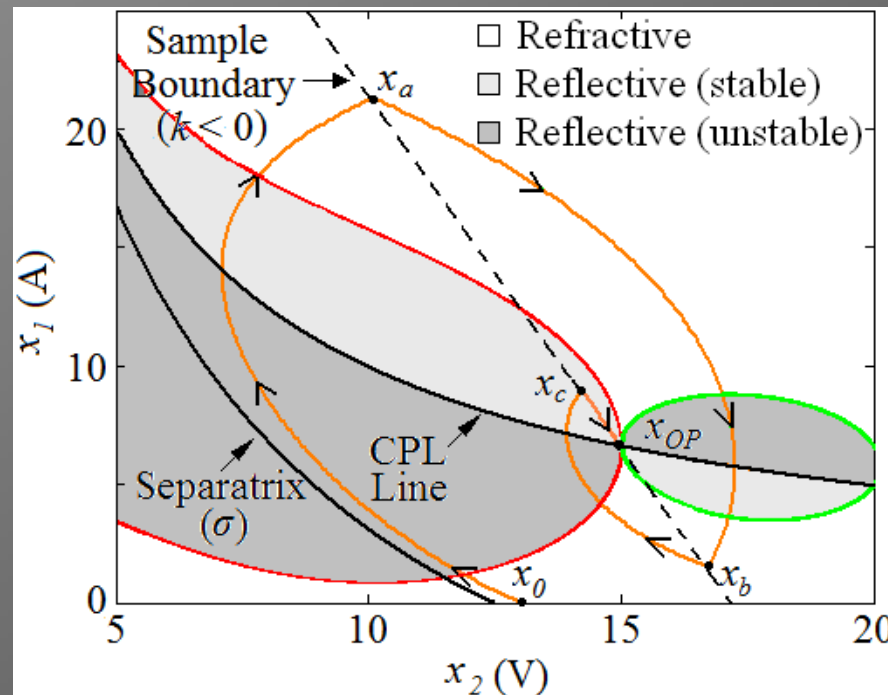

Stabilization

- 1st order boundary controller (buck converter)

- Switching behavior regions are found considering that trajectories are tangential at the regions boundaries.

$$\frac{f_{x_1}}{f_{x_2}} = \frac{dx_1}{dx_2} = k = \frac{x_1 - x_{1OP}}{x_2 - x_{2OP}}$$

- For ON trajectories:

$$\frac{C(E - x_2)}{L(x_1 - P_L / x_2)} = \frac{x_1 - x_{1OP}}{x_2 - x_{2OP}}$$

$$\begin{aligned} \varphi_{ON}(x) : L[x_1^2 x_2 - x_{1OP} x_1 x_2 - P_L x_1 + P_L x_{1OP}] \\ + C[Ex_{2OP} x_2 - (E + x_{2OP}) x_2^2 + x_2^3] = 0 \end{aligned}$$

- For OFF trajectories:

$$\frac{C(-x_2)}{L(x_1 - P_L / x_2)} = \frac{x_1 - x_{1OP}}{x_2 - x_{2OP}}$$

$$\varphi_{OFF}(x) : L[x_1^2 x_2 - x_{1OP} x_1 x_2 - P_L x_1 + P_L x_{1OP}] - C[x_{2OP} x_2^2 - x_2^3] = 0$$

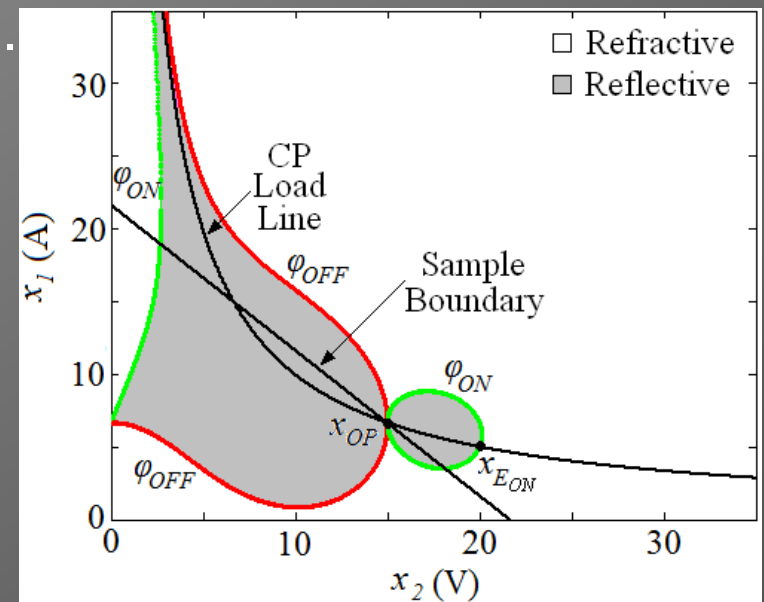

Stabilization

- 1st order boundary controller (buck converter)
- Lyapunov is used to determine stable and unstable reflective regions. This analysis identifies the need for $k < 0$

$$V(x) = \frac{C}{2} \|x - x_{OP}\|^2 > 0 \longrightarrow \dot{V}(x) = (1 + k^2)(x_2 - x_{2_{OP}}) \left(x_1 - \frac{P_L}{x_2} \right)$$

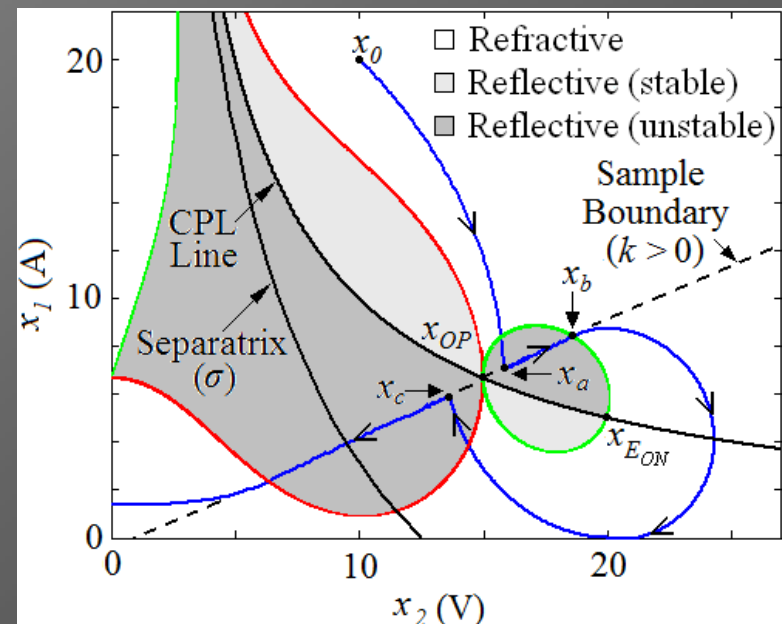
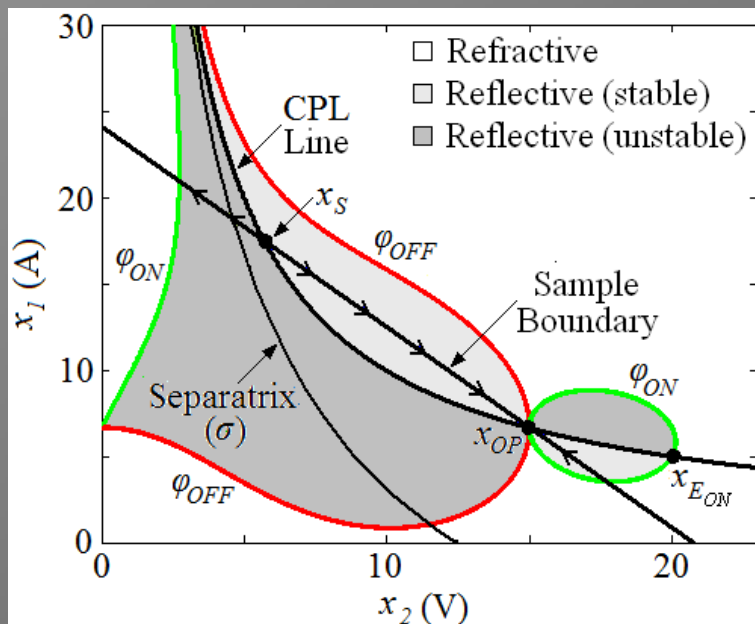

Stabilization

- 1st order boundary controller (buck converter)
- Simulated and experimental verification

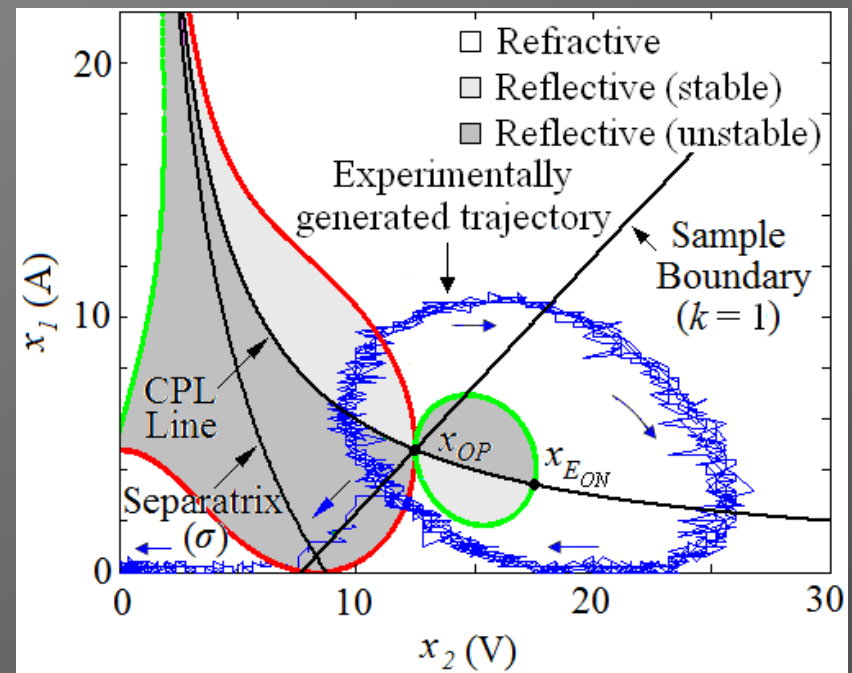
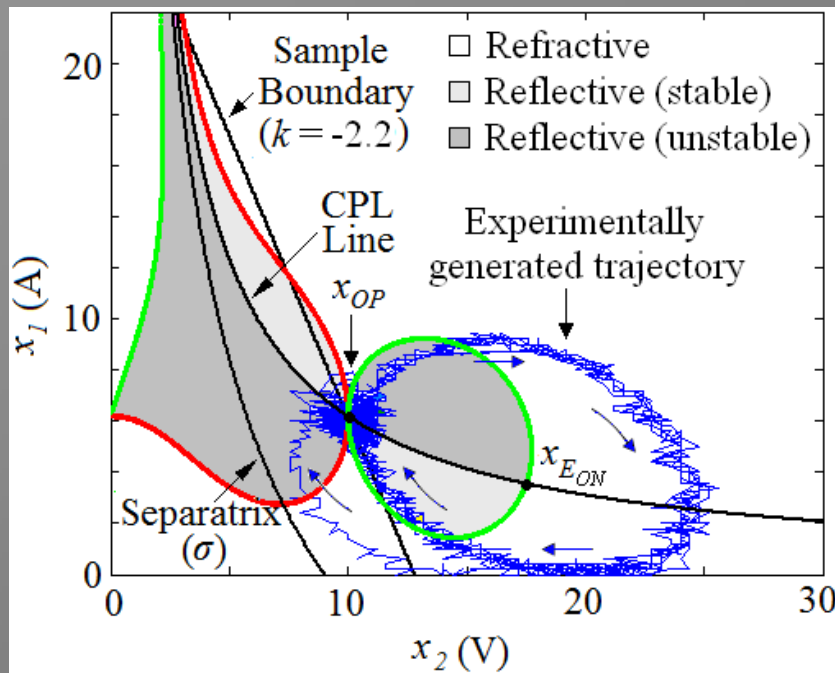

$$L = 480 \mu H, C = 480 \mu F, E = 17.5 V, P_L = 60 W, x_{OP} = [4.8 \quad 12.5]^T$$

Stabilization

- 1st order boundary controller (buck converter)
- Simulated and experimental verification

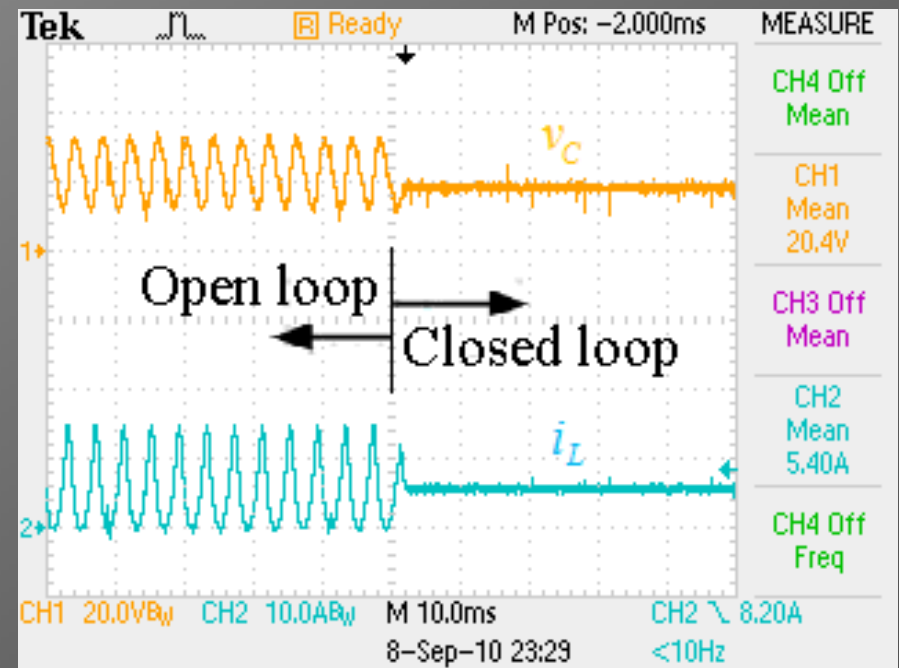
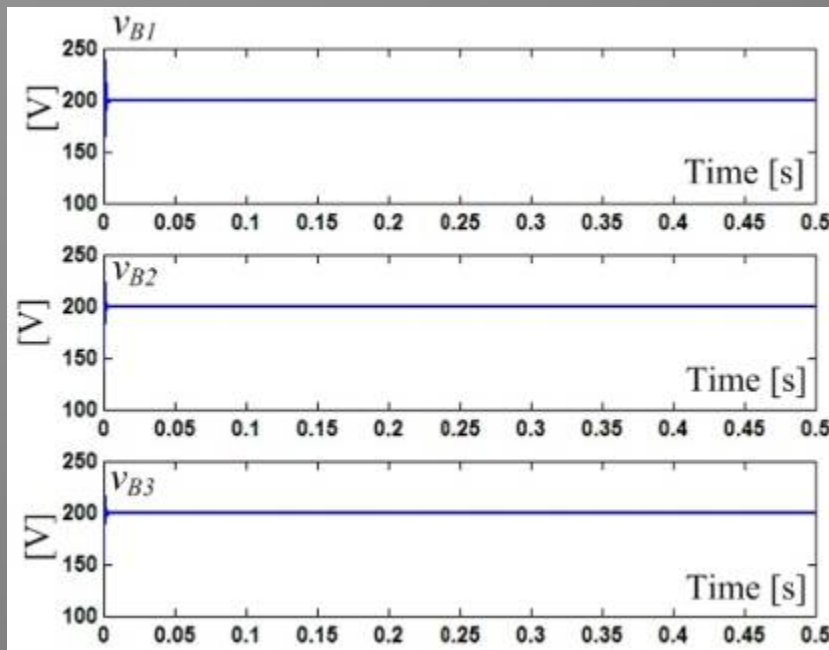

Buck converter with $L = 500 \mu\text{H}$, $C = 1 \text{ mF}$,
 $E = 22.2 \text{ V}$, $P_L = 108 \text{ W}$, $k = -1$, $x_{OP} = [6 \ 18]^T$

Stabilization

- 1st order boundary controller (buck converter)
- Line regulation is unnecessary. Load regulation based on moving boundary

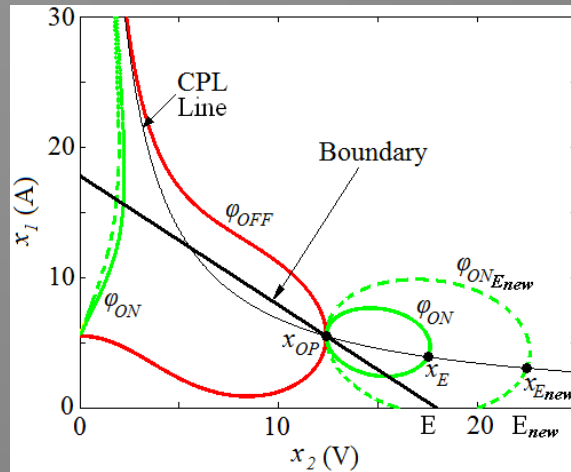

Line regulation: $\Delta E = +10V$ (57%)

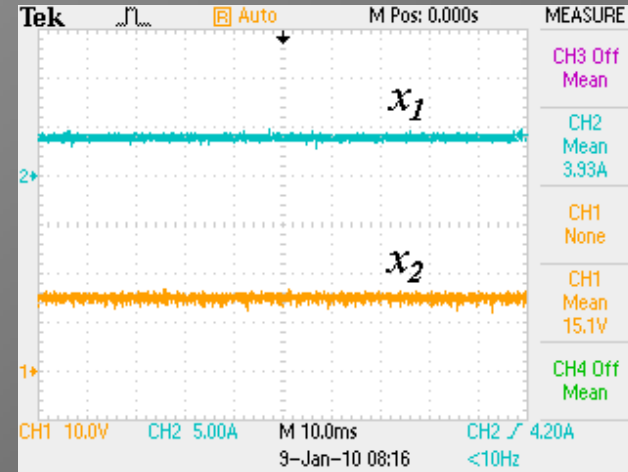

Line regulation: $\Delta E = +10V$ (57%)

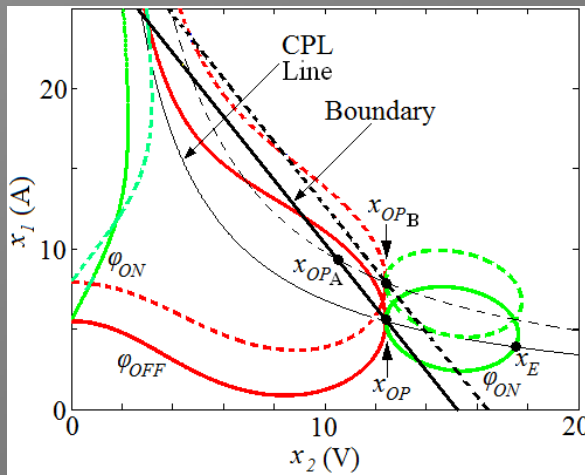

Load regulation: $\Delta PL = +20W$ (+29.3%)

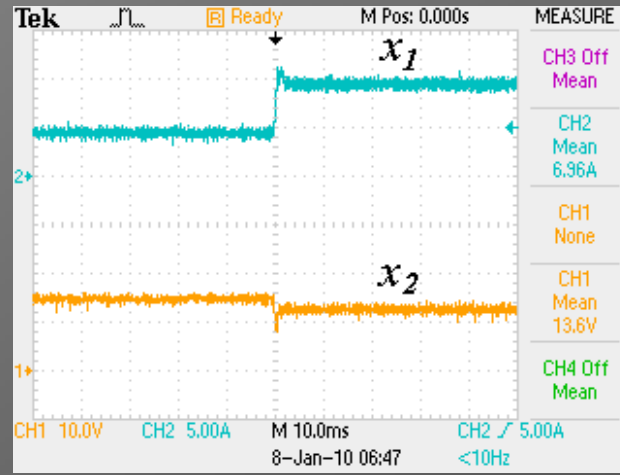

No regulation: $\Delta PL = +45W$ (+75%)

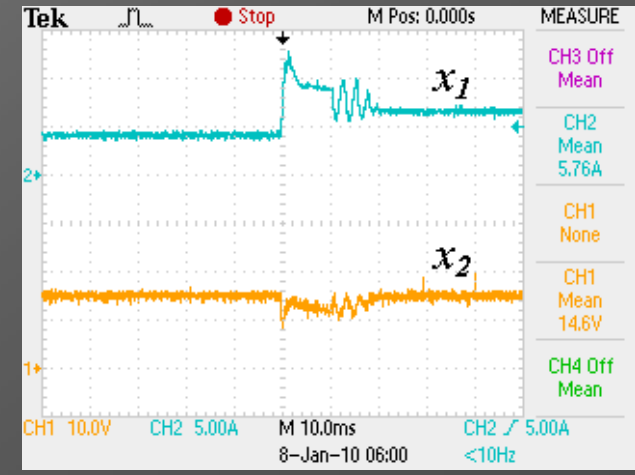

Load regulation: $\Delta PL = +45W$ (+75%)

Stabilization

- 1st order boundary controller (boost and buck-boost)
- Same analysis steps and results than for the buck converter.

Boost ($k < 0$)

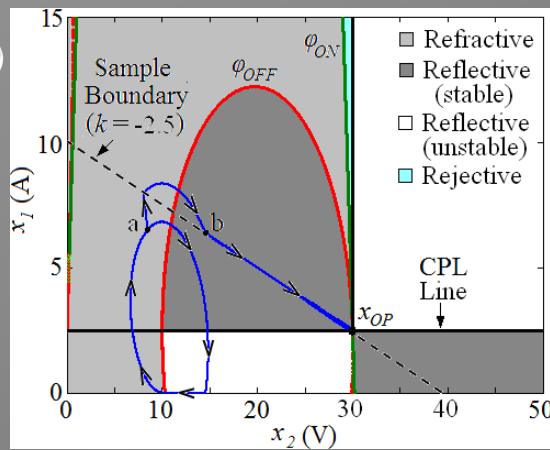

Buck-Boost ($k < 0$)

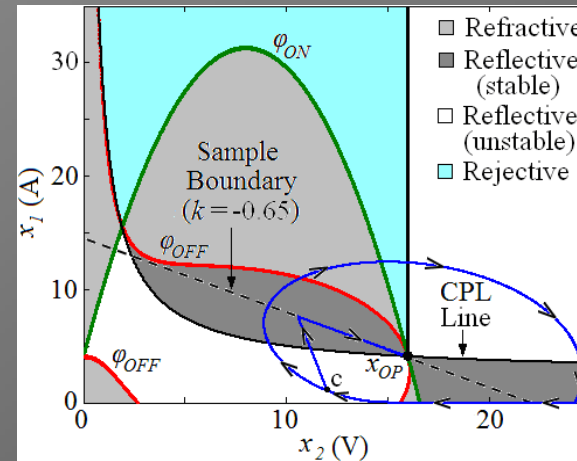

Boost ($k > 0$)

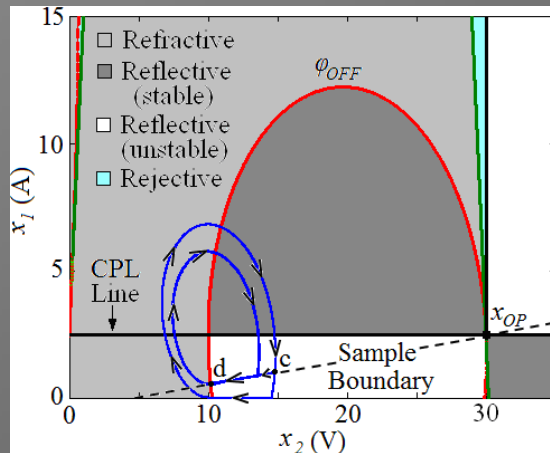

Buck-Boost ($k > 0$)

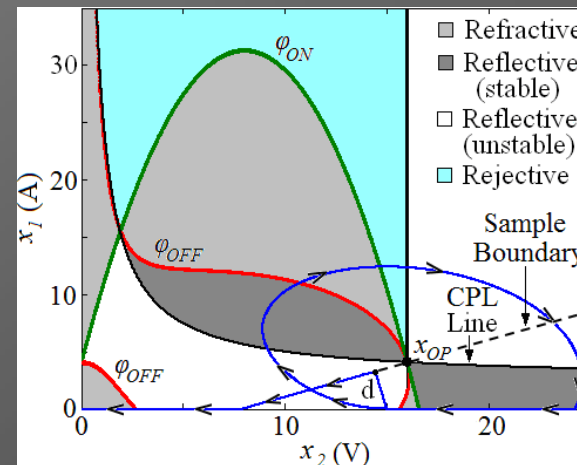

Stabilization

- 1st order boundary controller (boost and buck-boost)
- Experimental results.

Boost ($k < 0$)

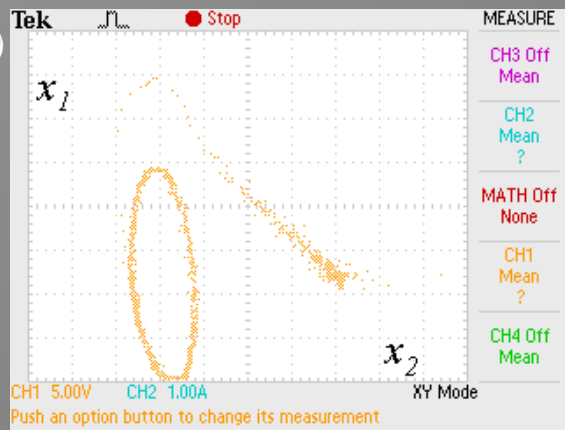

Buck-Boost ($k < 0$)

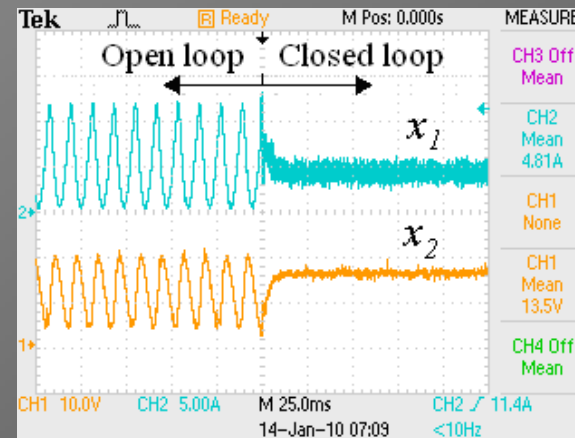

Boost ($k > 0$)

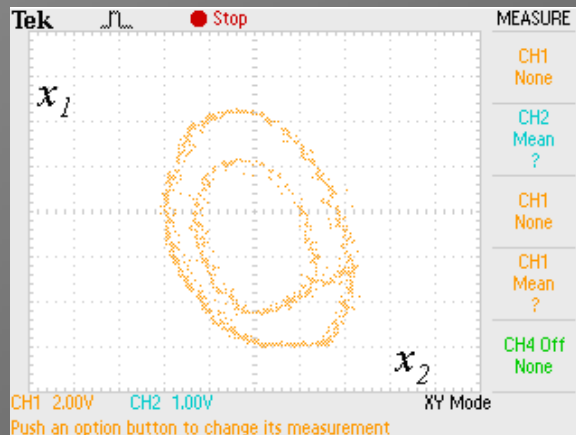

Buck-Boost ($k > 0$)

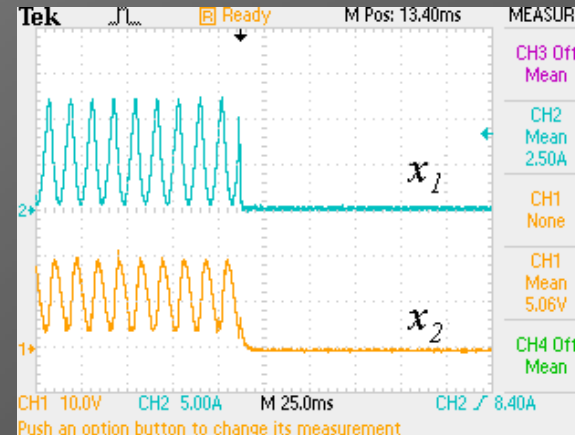

Stabilization

- 1st order boundary controller (boost and buck-boost)
- Experimental results for line and load regulation

Boost: Line regulation

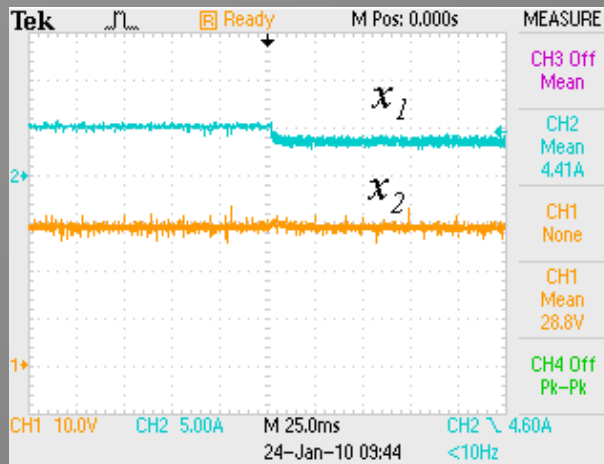

Buck-Boost: Line regulation

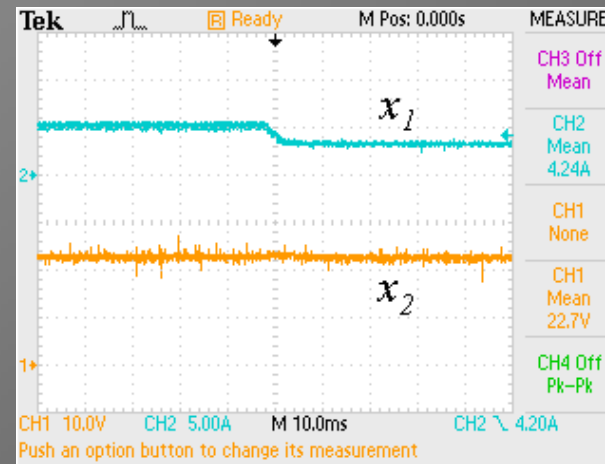

Boost: Load regulation

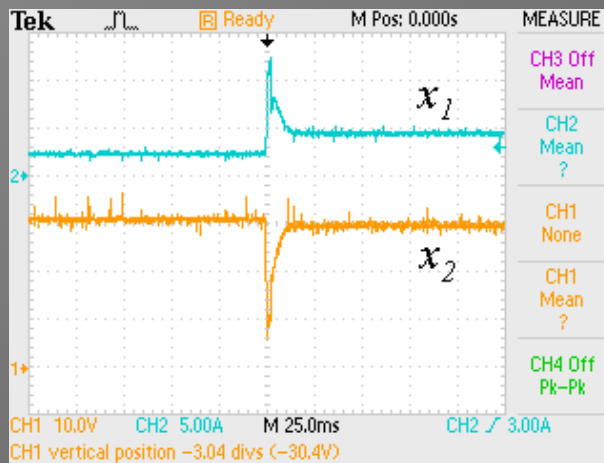

Buck-Boost: Load regulation

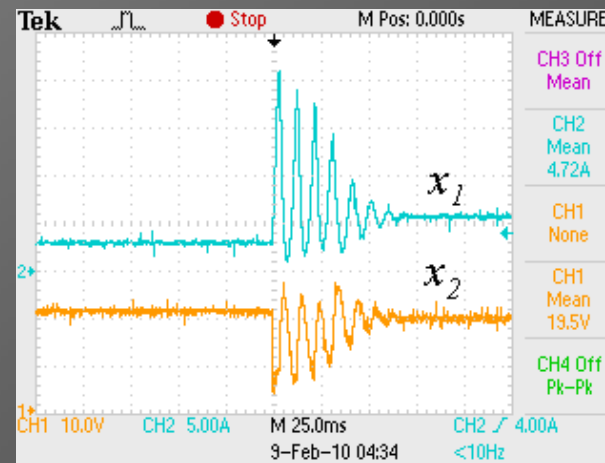

Stabilization

- Geometric controllers

- First order boundary with a negative slope is valid for all types of basic converter topologies.
- Advantages: Robust, fast dynamic response, easy to implement .

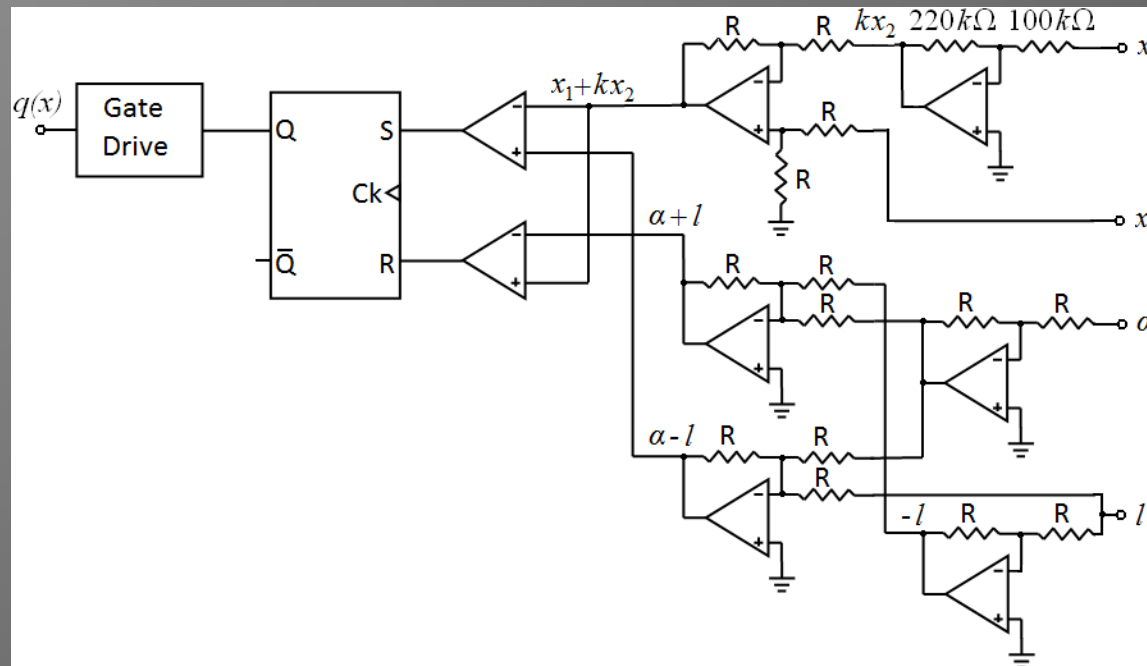

Conclusions

- Most renewable and alternative sources, energy storage, and modern loads are dc.
- Integration can be achieved through power electronics, but other stability issues are introduced due to CPLs.
- Control-related methods appear to be a more practical solution for CPL stabilization without reducing system efficiency.
- Nonlinear analysis is essential due to nonlinear CPL behavior.
- Boundary control offers more advantages than linear controllers and are equally simple to implement.
- Extended work focusing on rectifiers and multiple-input converters.

References for Additional Details

- A. Kwasinski and C. N. Onwuchekwa, “Dynamic Behavior and Stabilization of dc Micro-grids with Instantaneous Constant-Power Loads.” IEEE Transactions on Power Electronics, in print, appearing in the March 2011 issue.
- C. N. Onwuchekwa and A. Kwasinski, “Analysis of Boundary Control for Buck Converters with Instantaneous Constant-Power Loads.” IEEE Transactions on Power Electronics, vol. 25, no. 8, pp. 2018-2032, August 2010.
- C. Onwuchekwa and A. Kwasinski, “Analysis of Boundary Control for Boost and Buck-Boost Converters in Distributed Power Architectures with Constant-Power Loads,” in Proc. IEEE Applied Power Electronics Conference (APEC) 2011, Fort Worth, Texas, March, 2011.
- A. Kwasinski and P. T. Krein, “Stabilization of Constant Power Loads in Dc-Dc Converters Using Passivity-Based Control,” in Rec 2007 International Telecommunications Energy Conference (INTELEC), pp. 867-874.
- A. Kwasinski and P. Krein, “Passivity-based control of buck converters with constant-power loads,” in Rec. PESC, 2007, pp. 259-265.