

EE462L – Practice Final

Problem 1

Consider a telecommunications power plant with two possible configurations:

- Configuration A: n+1 redundant rectifiers with n = 1.
- Configuration B: n+1 redundant rectifiers with n = 4.

All of these rectifiers have a base mean up time of 500,000 hours ($\lambda = 2 \cdot 10^{-6}$) and a mean down time of 166.6 hours ($\mu = 6 \cdot 10^{-3}$). For each configuration, the rectifiers are sized based on the minimum power rating that is sufficient in order to power the load while still maintaining a redundant configuration.

The total load of this plant is 10 kW, the cost of each rectifier is of \$1/Watt. Consider also that when there are no failed rectifiers, all n+1 rectifiers are sharing the load in both configurations (i.e., the power output of all n+1 rectifiers is the same).

Answer the following questions:

- 1) What is the cost in rectifiers of configuration A and of configuration B?
- 2) What is the availability of configuration A and of configuration B?

In order to answer question #2 you need to do the necessary adjustments based on the effect of the temperature considering that the adjusting factor for temperature is

$$\pi_T = e^{\frac{E_a}{k} \left(\frac{1}{T_R} - \frac{1}{T_J} \right)}$$

where T_R is a reference temperature equal to 298 °K (25 °C), T_J is the junction temperature in degree Kelvins (°K), k is the Boltzman constant ($k = 8.617 \cdot 10^{-5}$ eV/°K), and E_a is the failure activation energy which in this case equals approximately 0.17 eV. Also consider that the temperature changes with the ratio of power output / rated power for each rectifier module according to the figure shown below.

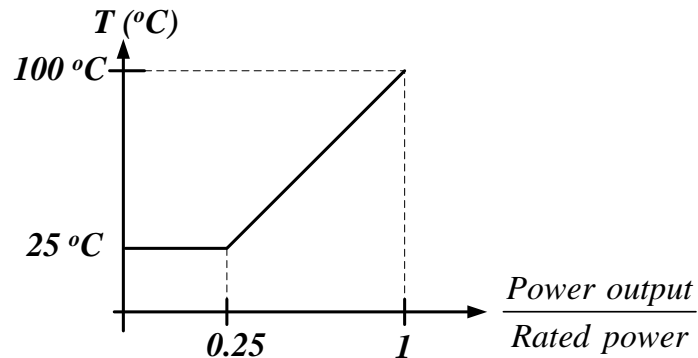

EE462L – Practice Final

Problem 2

The figure shown below represents one of the most common off the shelf PV systems you can find in the market today. It is composed of a PV array, a boost converter for maximum power point tracking (MPPT) and a single-phase inverter that feeds the load through the point of common coupling with the grid. The grid's voltage is 120 V. The solar array data is $V_{oc} = 125$ V, $I_{sc} = 32$ A, $I_{P,max} = 28$ A, and the total resistance of the inverter-grid interface is 0.1 ohm. Because of this resistance the efficiency of the inverter is 0.98. The system is designed considering that at the maximum expected home power consumption of 2 kW the inverter operates at a modulation index of 1. Answer the following questions for the case when the home power consumption is 2 kW and the PV array is at its MPP:

- 1) How much power is injected into the grid?
- 2) What is the value of V_{inv} ?
- 3) What is the dc link voltage V_{dc} ?
- 4) What is the boost converter duty cycle?

Remember that for a PV system, P_{max} is approximately equal to $0.7V_{oc}I_{sc}$. The efficiency of the boost converter is 1.

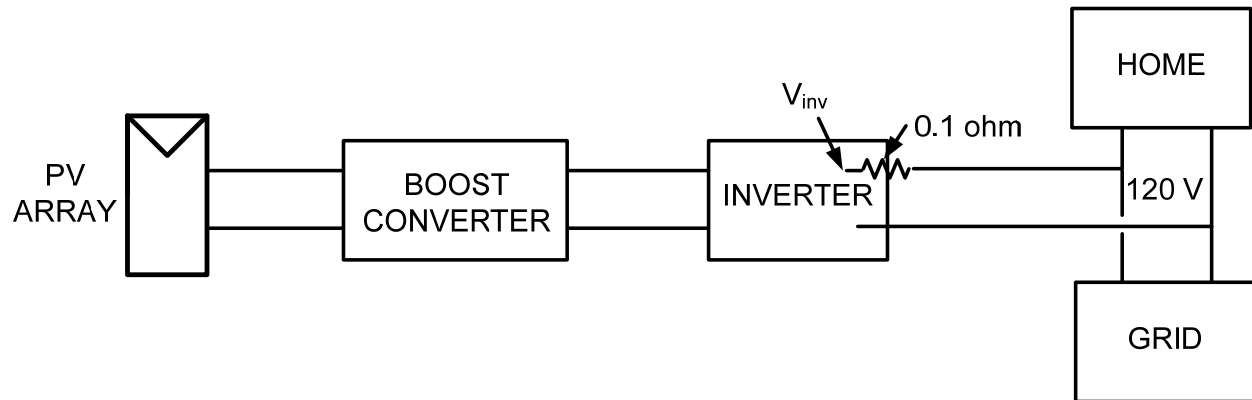

EE462L – Practice Final

Problem 3

Consider that you have a pump driven by a 20 kW 3-phase induction motor with the following **nominal** characteristics:

$V_{\text{input}} = 480 \text{ V}$ (line-to-line rms)

Nominal speed = 1740 RPM (revolutions per minute)

Nominal frequency = 60 Hz

Synchronous rotor speed: 1800 RPM

Due to operational requirements you need to adjust the output pressure of your pump to be $2/3$ of the pressure at its input. In order to achieve this goal you need to reduce the speed of the motor by $2/3$. If you are using an ASD with constant volt-per-Hertz control, what is the input voltage and frequency of the motor? If the modulation index of the inverter is 0.5, what is the dc voltage at the **input of the inverter** portion of the ASD? If the grid voltage is also 480 V (line-to-line rms) and the rectifier stage has an ideal efficiency and has an output dc voltage equal to 648V, what dc-dc converter do you need to insert in between the rectifier and the inverter? What is the duty cycle of this converter? Can you name another purpose of this converter?

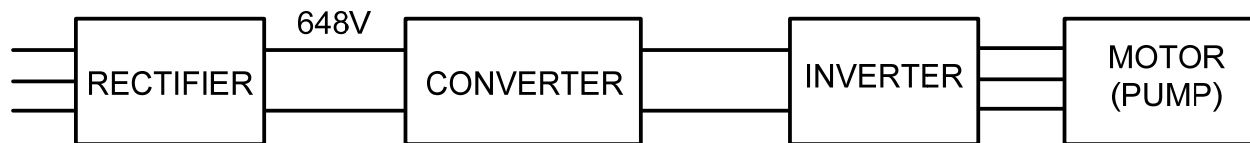

EE462L – Practice Final

Problem 4

Consider the following curves for an induction motor in an electric car. The motor has the following nominal characteristics:

Power = 20 kW

$V_{\text{input}} = 380 \text{ V}$ (line-to-line rms)

Nominal speed = 1740 RPM (revolutions per minute)

Nominal frequency = 60 Hz

Synchronous rotor speed: 1800 RPM

Consider that you are using regenerative braking to reduce the speed of the car by instantaneously changing the operational curve from the one on the right (nominal curve) to the one on the left. The motor is driven by an inverter with volts per Hertz control with an input voltage $V_{\text{dc}} = 1 \text{ kV}$. Calculate the modulation index before applying the brakes when the motor is at its nominal operating point (point A). When brakes are applied, what is the new motor input frequency and modulation index (point B)?

(Remember that line-to-line voltages are $\sqrt{3}$ times the line-to-neutral voltages. Also remember that the operation portion of the torque-speed curve can be considered a line). Hint: the electrical angular frequency corresponding to motor input voltage is proportional to ω_s indicated in the figure below.

