

Consider the current and voltage waveforms in the figure shown below measured at point A in the circuit schematic also shown below. Indicate the average current, the rms current and the amplitude of the current sinusoidal components. What is the frequency of the current highest harmonic component? What is the average power consumed by the load? What is the power factor observed at point A? How much power is dissipated in R_{cable} ? Is the load a linear circuit? Why or why not?

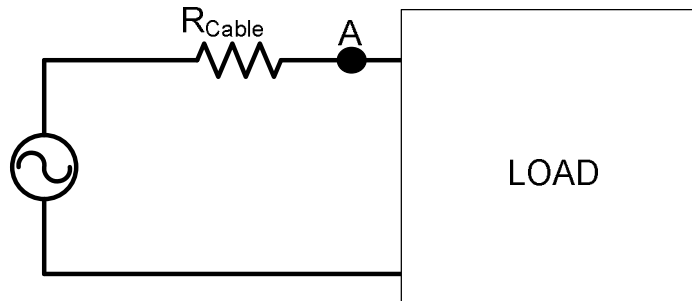
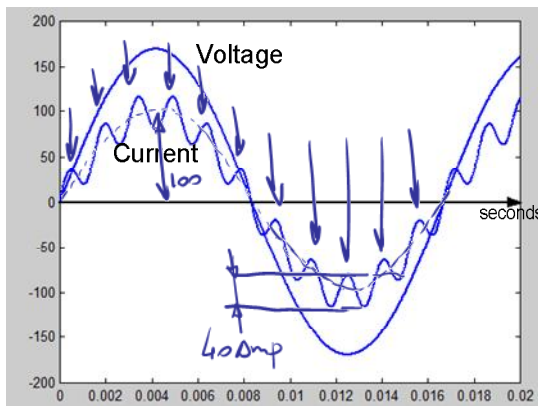

$$i(t) = 100 \overset{I_{\text{fundamental}}}{\sin(2\pi 60 t)} + 20 \overset{I_{11}}{\sin(11.2\pi 60 t)}$$

$$v(t) = 170 \sin(2\pi 60 t)$$

$f_{\text{highest}} = 11 \times 60 = 660 \text{ Hz}$

$$I = 0$$

$$I_{\text{rms}}^2 = \frac{100^2}{2} + \frac{20^2}{2} = 5600 \rightarrow I_{\text{rms}} = 72.11 \text{ A}$$

$$P = V_{\text{rms}} I_{\text{rms}} = 120 \cdot 70.21 \approx 8.5 \text{ kW}$$

$$\text{PF} = \frac{P}{V_{\text{rms}} I_{\text{rms}}} = \frac{8500}{120 \cdot 72.11} = 0.98$$

$$P_R = I_{\text{rms}}^2 R_{\text{cable}}$$

Nonlinear because the response to a single frequency voltage is \geq multiple-frequency current

The scope captures below show part of the voltage waveform across a DBR diode (left) and the voltage across a 0.01 Ohm input sensing resistor (right). What are the conduction losses in the DBR diodes? If the output power is 300 W and the only losses in the DBR are those in the diodes, what is the DBR efficiency?

Now assume that the input voltage doubles. As a result of this input voltage increase, the output power is 1150 W, the peak input current doubles and the diodes conduction time increase 10 %. What are the new conduction losses and efficiency of the rectifier?

Note: For the left scope capture the vertical scale is 0.5V/division and for the right scope capture the vertical scale is 100 mV/division. In both cases the horizontal scale is 2 ms/division.

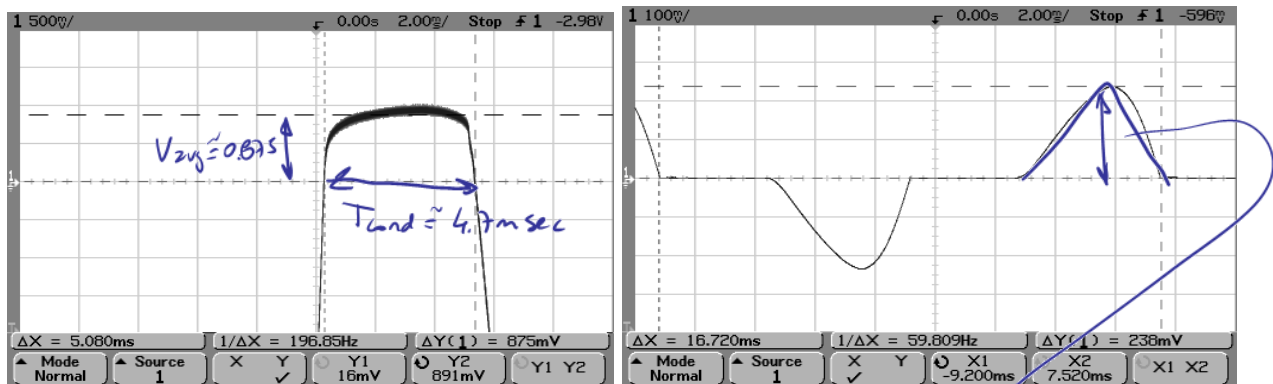

$$P_{avg} = 4 V_{avg} I_{avg} T_{cond} f =$$

$$= 4 \times 0.875 \times 11.5 \times 4.7 \cdot 10^{-3} \times 60 = 11.35 \text{ W}$$

$$\eta = \frac{300}{300 + 11.35} = 0.96$$

$$I_{peak} = \frac{0.23}{0.01} = 23 \text{ A}$$

$$I_{avg} = \frac{23}{2} = 11.5 \text{ A}$$

Double Input voltage:

$$P_{avg} = 4 \times 0.875 \times 23 \times 1.1 \times 4.7 \cdot 10^{-3} \times 60 = 24.97$$

$$\eta = \frac{1150}{1150 + 24.97} = 0.978$$

The light dimmer circuit was modified without including a capacitor (we assume that when the diac conducts it is still possible to generate a current pulse that triggers the triac). If the input voltage is 120 Vrms, and the diac breakover voltage is 35 V, what is value of R_p that yields a firing angle α of 30° ? What is value of R_p that yields a firing angle α of 120° ?

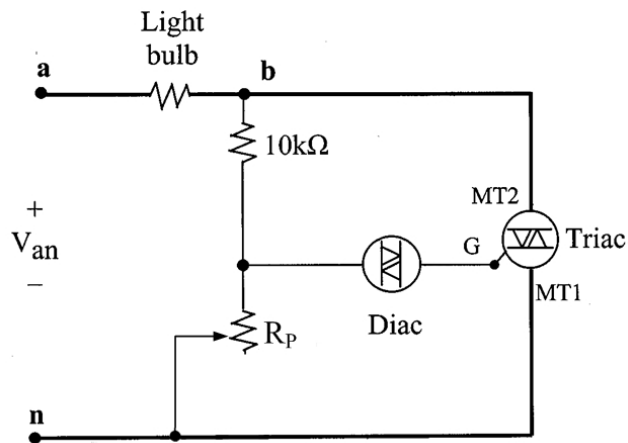

$$V_{ep} = \frac{R_p}{R_p + 10k} V_{an} \rightarrow R_p = \frac{V_{Rp} \cdot 10k}{V_{an} - V_{Rp}}$$

$$R_{p\alpha=30} = \frac{35 \cdot 10000}{\sqrt{2} \cdot 120 \sin(30) - 35} \approx 7k\Omega$$

Without a capacitor it is not possible to have firing angles over 90°

Sample test

Please, show all your work on the test sheets. A correct answer without supporting work gets no credit. One sheet of notes is permitted. Write your name in all pages. Do not un-staple. Please **be neat**. Otherwise, you may end up loosing credit for correct answers if I cannot find or understand them. You have 50 minutes to complete the test.

Problem 1 (30 points)

Consider that you are measuring the harmonic content of a current signal with a 5 A, 100 mV shunt resistance, and your measurements with respect to a 1 mVrms reference are:

$$V(0 \text{ Hz}) = 40 \text{ dB}$$

$$V(60 \text{ Hz}) = 20 \text{ dB}$$

$$V(180 \text{ Hz}) = 17 \text{ dB}$$

$$V(300 \text{ Hz}) = 12 \text{ dB}$$

Sketch the FFT graph and calculate the current corresponding to each component. If this is the current measured at the output of a 12 Vdc voltage source, which is the power provided by this source?

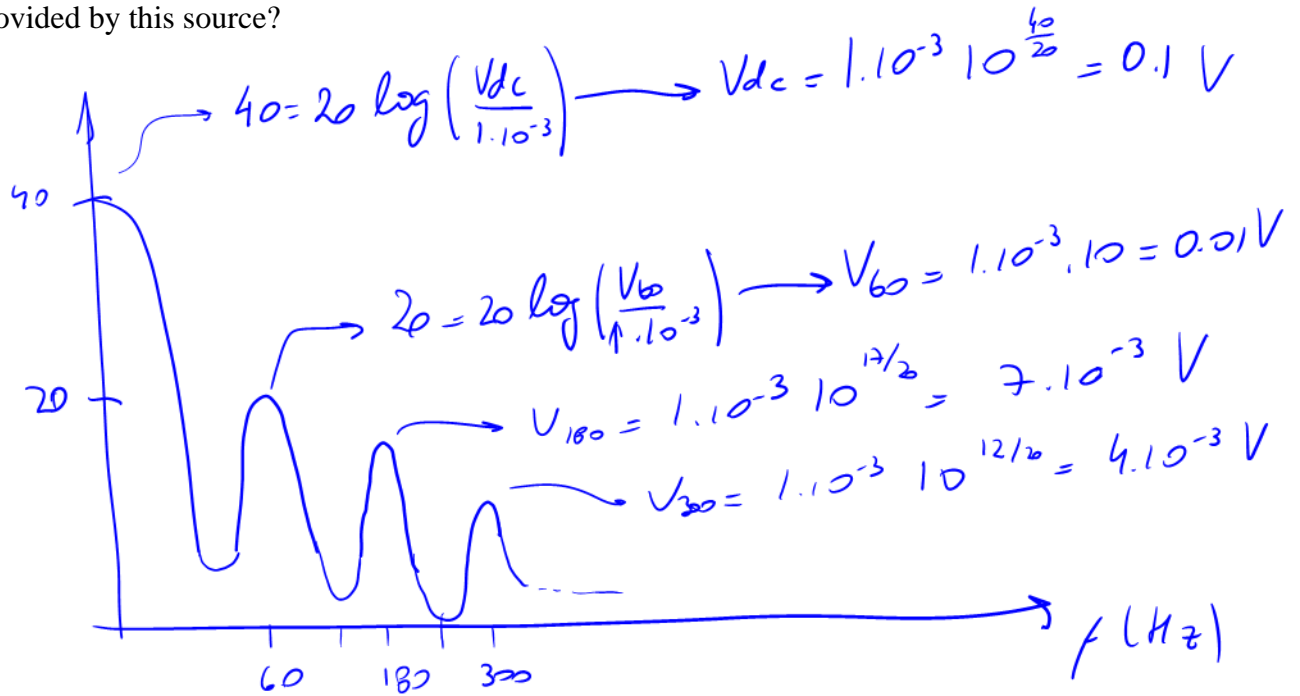

$$I_{dc} = \frac{0.1 \cdot 5}{0.1} = 5 \text{ A}, \quad I_{60} = \frac{0.01 \cdot 5}{0.1} = 0.5 \text{ A}, \quad I_{180} = \frac{7 \cdot 10^{-3} \cdot 5}{0.1} = 0.35 \text{ A}, \quad I_{300} = 0.2 \text{ A}$$

$$P = 12 \cdot 5 = 60 \text{ W}$$

Problem 2 (25 points)

The thick trace in the figure below represents the output of a DBR with a 5 kW load. The DBR is connected a regular wall outlet in Europe with a 220 Vrms voltage and a 50 Hz frequency. What capacitance is needed on the DBR output in order to have a peak-to-peak voltage ripple of 5% of the peak voltage? Suppose that you travel to the US where the line frequency is 60 Hz and the voltage is 120 Vrms. Does the voltage ripple change? If so, what's its new value?

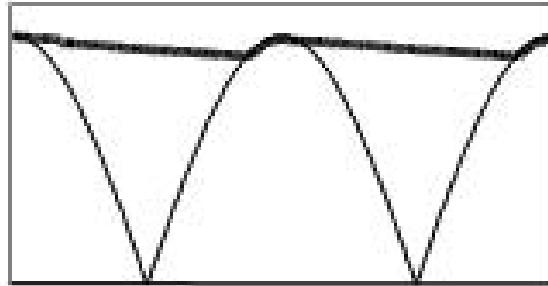

Europe

$$\Delta V_{pp} = \frac{P}{2fCV_p} \rightarrow C = \frac{P}{2fV_p\Delta V_{pp}}$$

$$V_p = \sqrt{2} \cdot 220 = 311.17, \quad \Delta V_{pp} = 0.05 \cdot 311.17 = 15.55$$

$$C = \frac{5000}{2 \cdot 50 \cdot 311.17 \cdot 15.55} \approx 10 \text{ mF}$$

US

Yes, it changes

$$\Delta V_{pp} = \frac{P}{2fCV_p} = \frac{5000}{2 \cdot 60 \cdot 0.01 \cdot \sqrt{2} \cdot 120} = 24.55$$

↓
About 14% !!

Additional info:

Capacitance needed to reach 5% voltage ripple in the US

$$C = \frac{5000}{2 \cdot 60 \cdot \sqrt{2} \cdot 120 \cdot 0.05 \sqrt{2} \cdot 120} = 29 \text{ mF}$$

Problem 3 (30 points)

The light dimmer circuit was modified by including a switch and replacing your ac source by a dc source. When the switch closes at $t = 0$, the capacitor is fully discharged. When the capacitor voltage reaches 50 V, the light bulb turns on and stays on. What is the value of R_p that makes the light bulb to go on at $t = 5$ milliseconds. Hint: you may ignore the light bulb resistance. The capacitor charges according to $v_C(t) = V_F \left(1 - e^{-\frac{t}{RC}} \right)$

where V_F is the fully charged voltage.

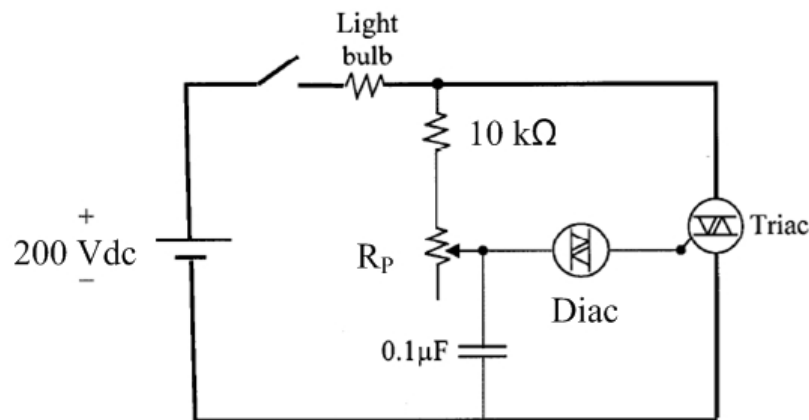

$$50 \text{ V} = 200 \left(1 - e^{-\frac{5 \cdot 10^{-3}}{1 \cdot 10^{-7} R}} \right)$$

$$\frac{50}{200} = 1 - e^{-5 / 1 \cdot 10^{-4} R}$$

$$e^{-5 / 1 \cdot 10^{-4} R} = \frac{3}{4}$$

$$-\frac{5}{1 \cdot 10^{-4} R} = \ln \left(\frac{3}{4} \right) = -0.287$$

$$R = \frac{5}{0.287 \cdot 10^{-4}} = 173803 \Omega$$

$$R_p = 173803 - 10000 = 163803 \Omega$$

Problem 4 (5 points each)

Please, select the correct answer for the following questions. **Provide a justification for your answers.**

4.1) Suppose you are on the equator and you want to maximize the solar radiation received on a solar panel on December 21. Then you will orient the panel in the following way:

- a) Azimuth 180° , Tilt 23.45°
- b) Azimuth 0° , Tilt 23.45°
- c) Azimuth 180° , Tilt 0°
- d) Azimuth 0° , Tilt 0°
- e) None of the above

Remember that azimuth 0° = North

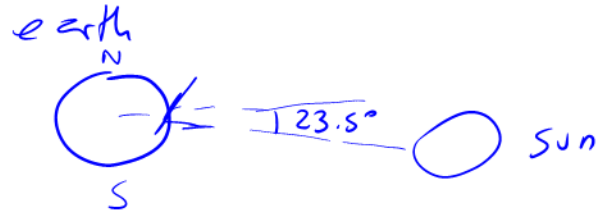

4.2) Consider a gate drive circuit for a MOSFET. The saw-tooth signal at the PWM chip has varies between ground and 5 V. In order to obtain a constant duty cycle of 0.4 the amplitude of the control reference voltage is

- a) 0V
- b) 1 V
- c) 2 V
- d) 3 V
- e) 4 V
- f) 5 V
- g) None of the above



4.3) For each of the following statements choose the correct answer

a) It is OK to connect an inductor in series with a switch

TRUE

FALSE

→ Inductors tend to behave like current sources

b) It is OK to connect a capacitor in series with a switch.

TRUE

FALSE

→ There are no issues with this

c) In steady state the average current through an inductor is zero.

TRUE

FALSE

→ The voltage is zero

d) In steady state the average voltage through an inductor is zero.

TRUE

FALSE

→ Because of the previous answer