

EE382M

VLSI-II

EDP-TC: Early Design Planning for Timing Closure

Spring 2017

Mark McDermott

Agenda: Early Design Planning for Timing Closure



- **Basics of Timing**
- **EDP-TC What is It?**
- **EDP-TC Goals & Objectives**
- **EDP-TC Starting Point Data Requirements**
- **EDP-TC Methodology How-To**
 - Methodology Overview
 - Block Size Estimation (another lecture)
 - Block Timing Assertions Generation
 - Delay Estimation
- **EDP-TC End Products**
- **Specifics for the Class Project: EDP-TC Floor-planning for Design Space Exploration & Timing Closure**

- **TA - Timing Analysis**
- **STA - Static Timing Analysis**
- **SSTA – Statistical Static Timing Analysis**
- **DCL - Delay Calculator Language**
- **AT - Arrival Time**
- **RAT - Required Arrival Time**
- **PT – Pass-through**
- **LCB - Local Clock Buffer**
- **EDP - Early Design Planning**
- **EDP-TC - Timing Closure for EDP**
- **CL – Combinational Logic**
- **FF – Flip Flop**

Design Flow Review

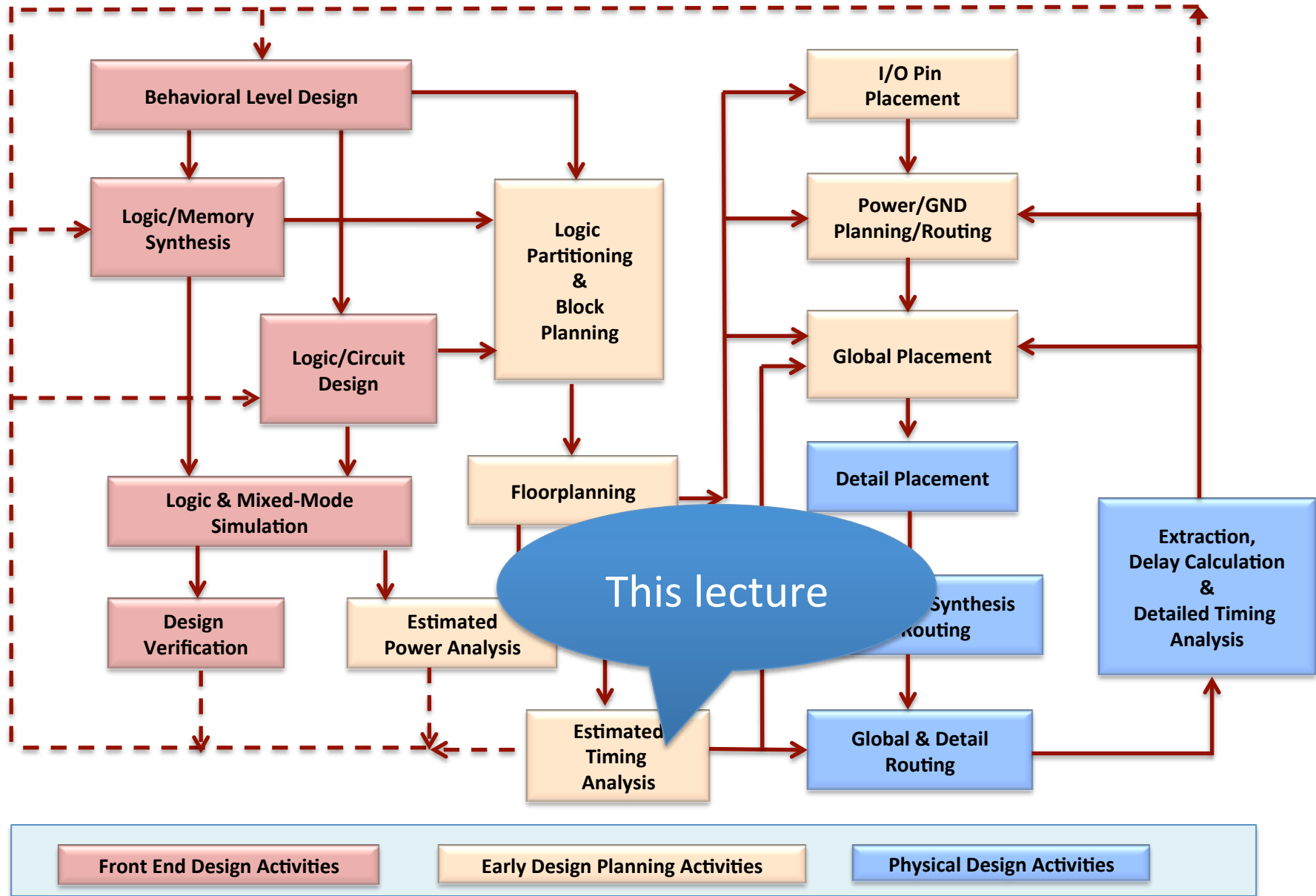

Basics of Timing: AT, RAT, Cycle time

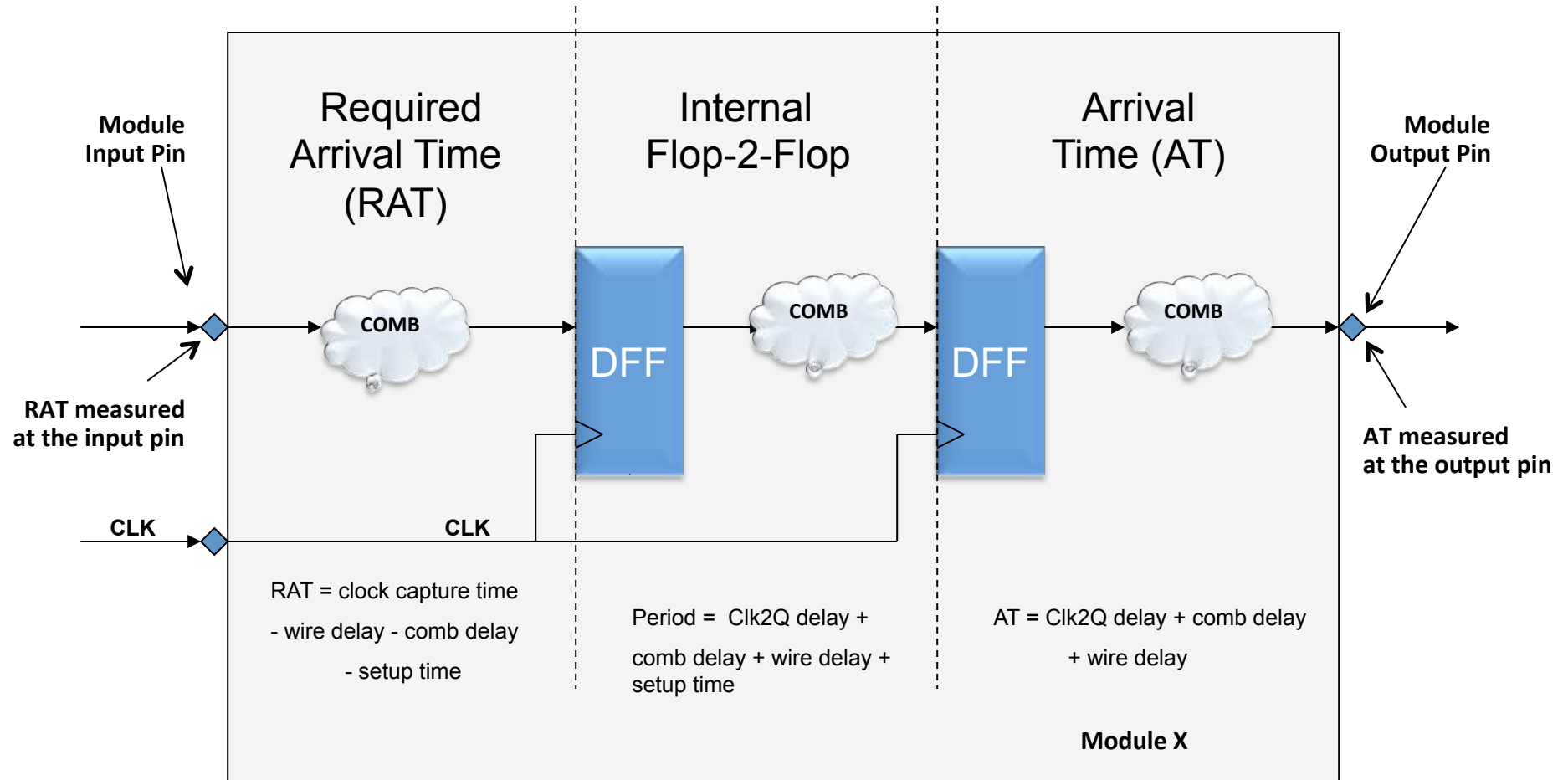

Basics of Timing: Pin-2-Pin (Pass-through)

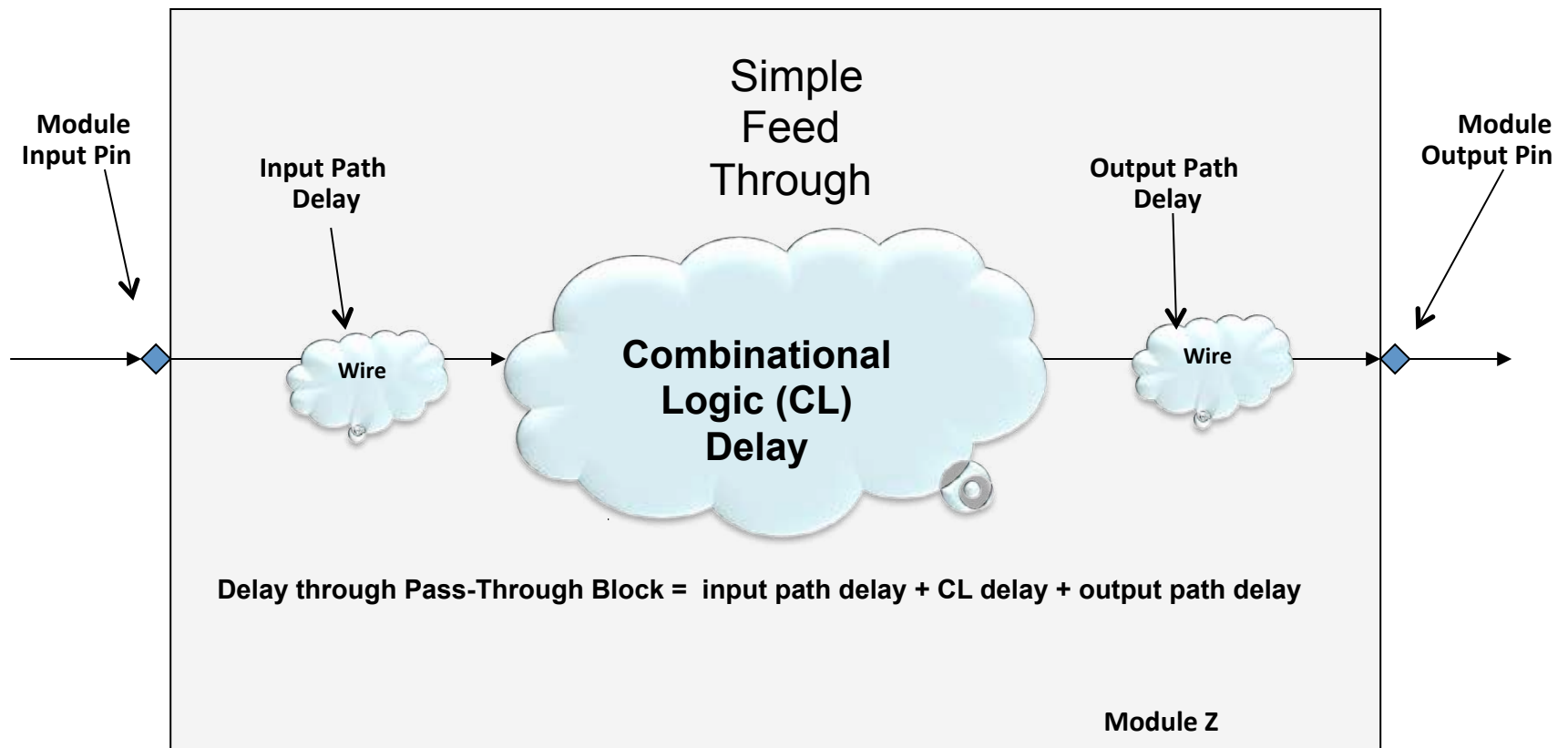

Example

We will walk through the below code to show how to calculate pass-throughs, RATs and ATs.

```
input      du_stall;
input      icpu_ack_i;
input      icpu_err_i;
input      flushpipe;
output     genpc_freeze;

reg        flushpipe_r;

assign genpc_freeze = du_stall | flushpipe_r;

always @ (posedge clk or posedge rst)
  if (rst)
    flushpipe_r <= 1'b0;
  else if (icpu_ack_i | icpu_err_i)
    flushpipe_r <= flushpipe;
  else if (!flushpipe)
    flushpipe_r <= 1'b0;
```

Example – Arrival Time (AT)

Computing Arrival Times

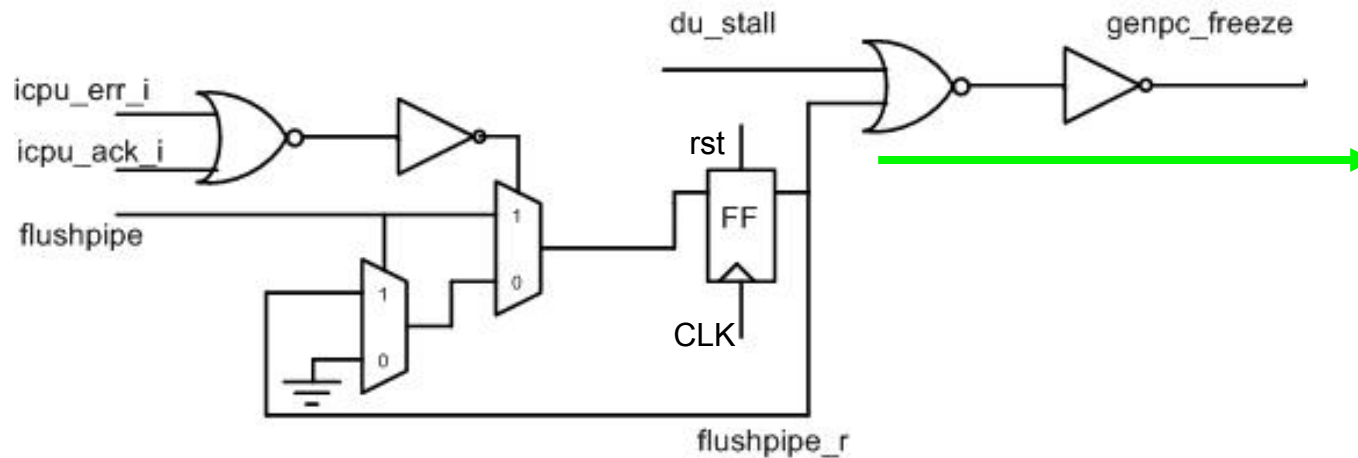

flushpipe_r is launched by a FF. Clock2Q delay is 134.7ps

flushpipe_r goes through a NOR2 and INV for a delay of 72.28ps

Total Arrival Time is: Clock2Q + Logic Delay + wire delay = 134.7 + 72.28 + wire delay

Arrival Time for **genpc_freeze** is: ~208ps + wire delay

Example – Required Arrival Time (RAT)

Computing Required Arrival Times

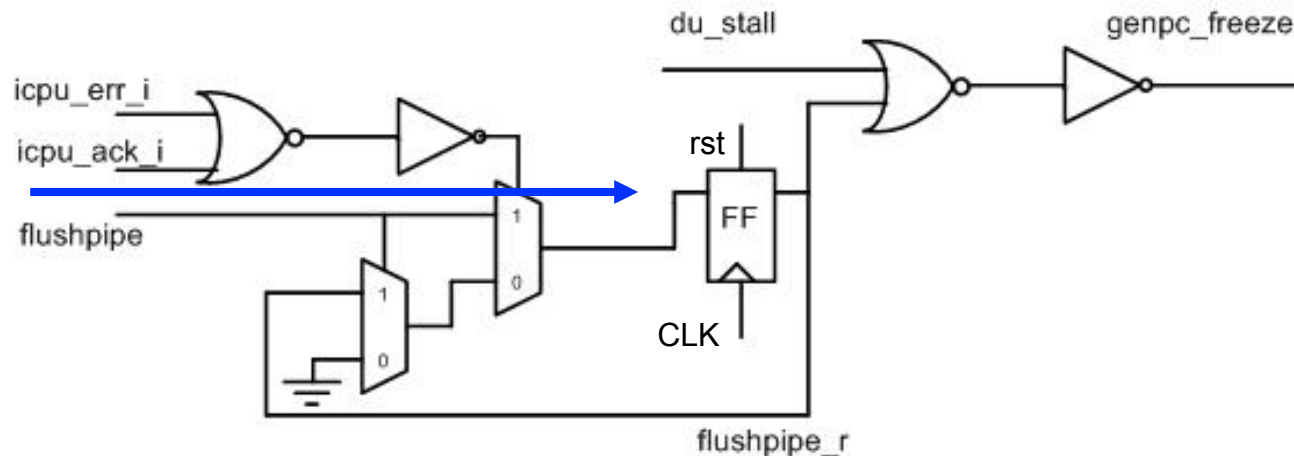

RAT for `icpu_err_i` and `icpu_ack_i` includes delay through a NOR, INV, MUX, as well as the setup time to the FF

RAT for `flushpipe` includes 2 MUX delays and the setup time (use the worst case here, since `flushpipe` has 2 paths to the FF).

Since this path is receiving, assume the gates are minimum sizes.

Since we won't have the nice fanout of 3 working for us in this case, it's time for some Logical Effort fun! (Also applies to Arrival Time calculations.)

Example – Required Arrival Time (RAT)

Computing Required Arrival Times

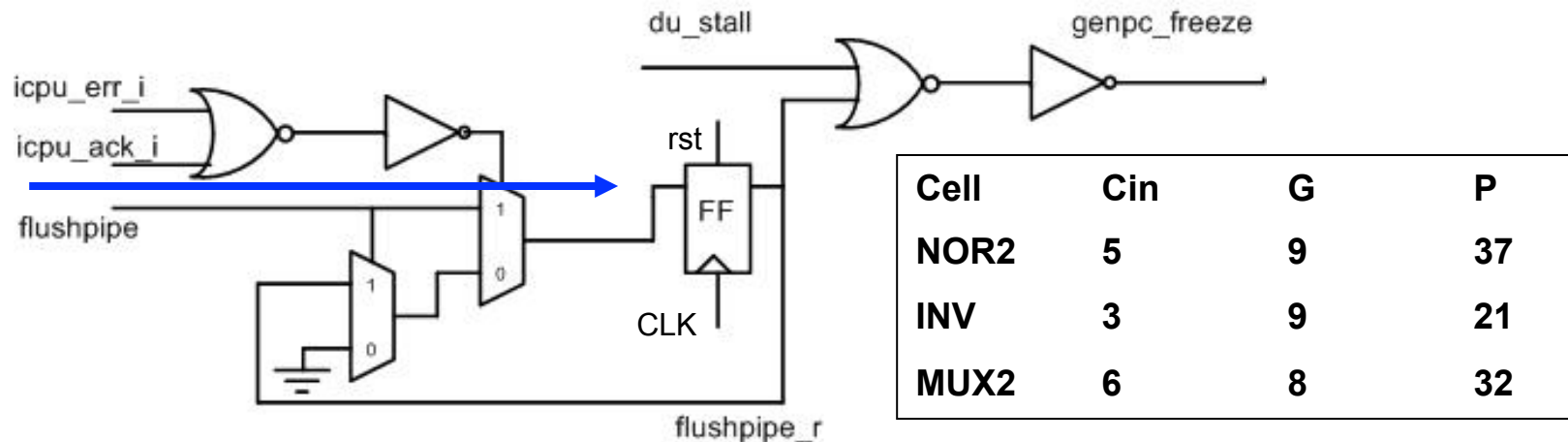

The g and p values for the NOR, MUX, and INV are listed in the table to the right.

To use, multiply 'g' by 'h', which is the Cout/Cin value, and add 'p'

The NOR has $h=3/5$ (INV/NOR), so its formula is $9*3/5+37 = 42.4ps$ (note that it's larger than the FO3 value in the spreadsheet -> this shows that logical effort is not quite accurate...)

The INV is driving a minimum MUX, so the 'h' is $6/3$ (MUX/INV). Delay = $9*2+21 = 39ps$

The MUX is driving a FF (assume $cin=6$), so the 'h' is $6/6$. Delay = $8*1+32 = 40ps$

Example – Required Arrival Time

Computing Required Arrival Times

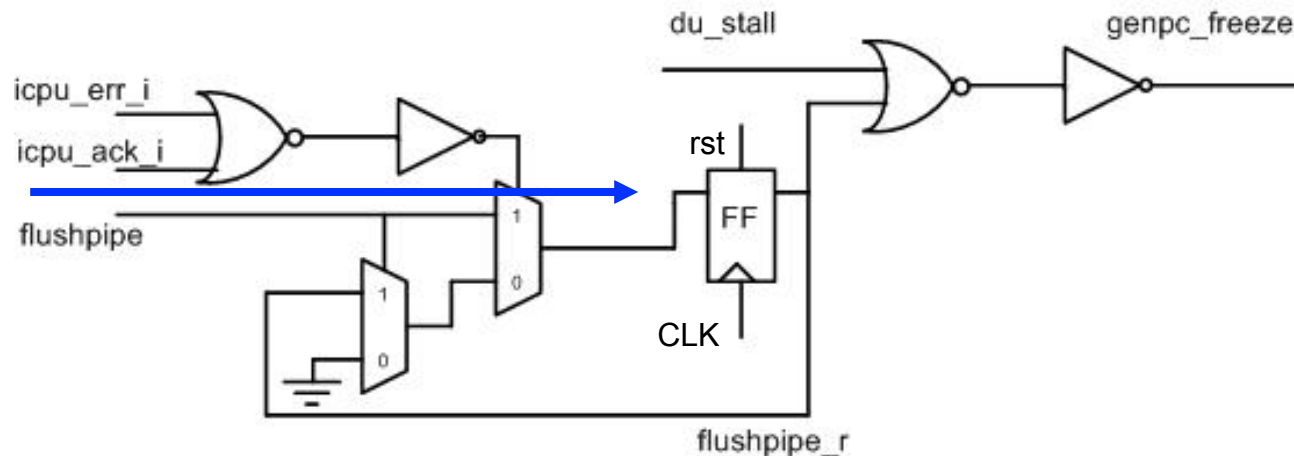

We now have everything we need to compute the RATs for the three inputs. Remember that for a RAT, you subtract the delay from the usable clock period!

For `icpu_err_i`, the RAT is Clock Period - NOR - INV - MUX - Setup = $900 - 42.4 - 39 - 40 - 100 = 678.6\text{ps}$

`icpu_ack_i` sees the same path, so it's RAT is also 678.6 ps

`flushpipe` sees Clock Period - MUX - MUX - Setup = $900 - 40 - 40 - 100 = 720\text{ps}$

NOTE that again, these do not include any wire delay!!!

Example – Internal F2F Path

Computing Internal Flop-to-Flop Times

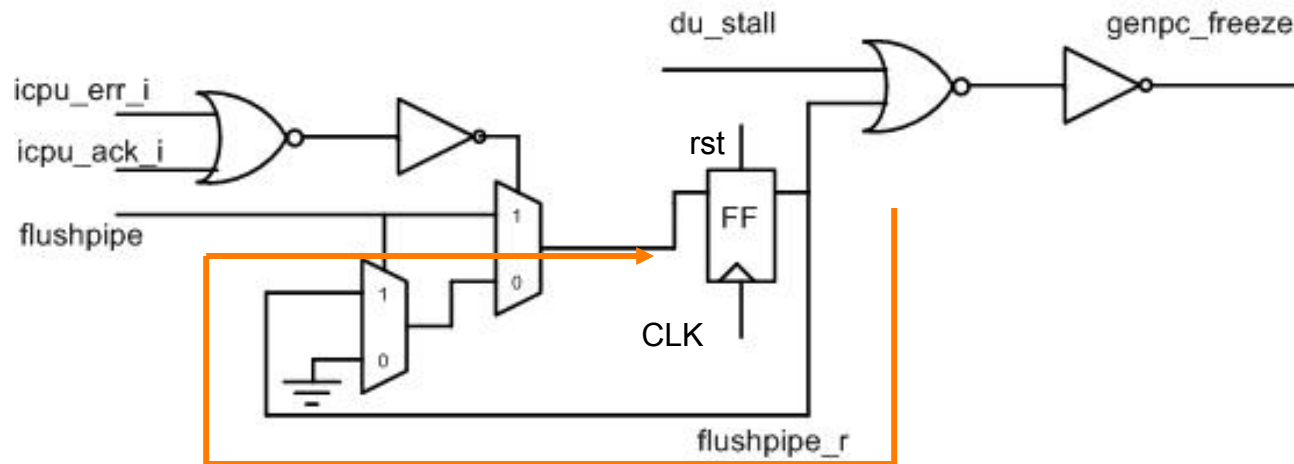

You need to verify that all internal paths meet timing as well.

In this case you would make sure that the C2Q + Mux Delay + Mux Delay + Setup time is less than the clock period (900ps)

Delay = 134.7 + 40 + 40 + 100 = 314.7 ps < 900 ps -> In this case we meet timing

- **The process to identify and close on chip area and timing objectives and constraints during the micro-architectural design phase.**

- **Rapid Design space exploration during micro-architectural phase**
 - Drive changes to the micro-architecture to enable achieving area and timing goals.
 - Enabling Rapid Convergence on Area & timing closure during design implementation phase.

Timing Closure Progression

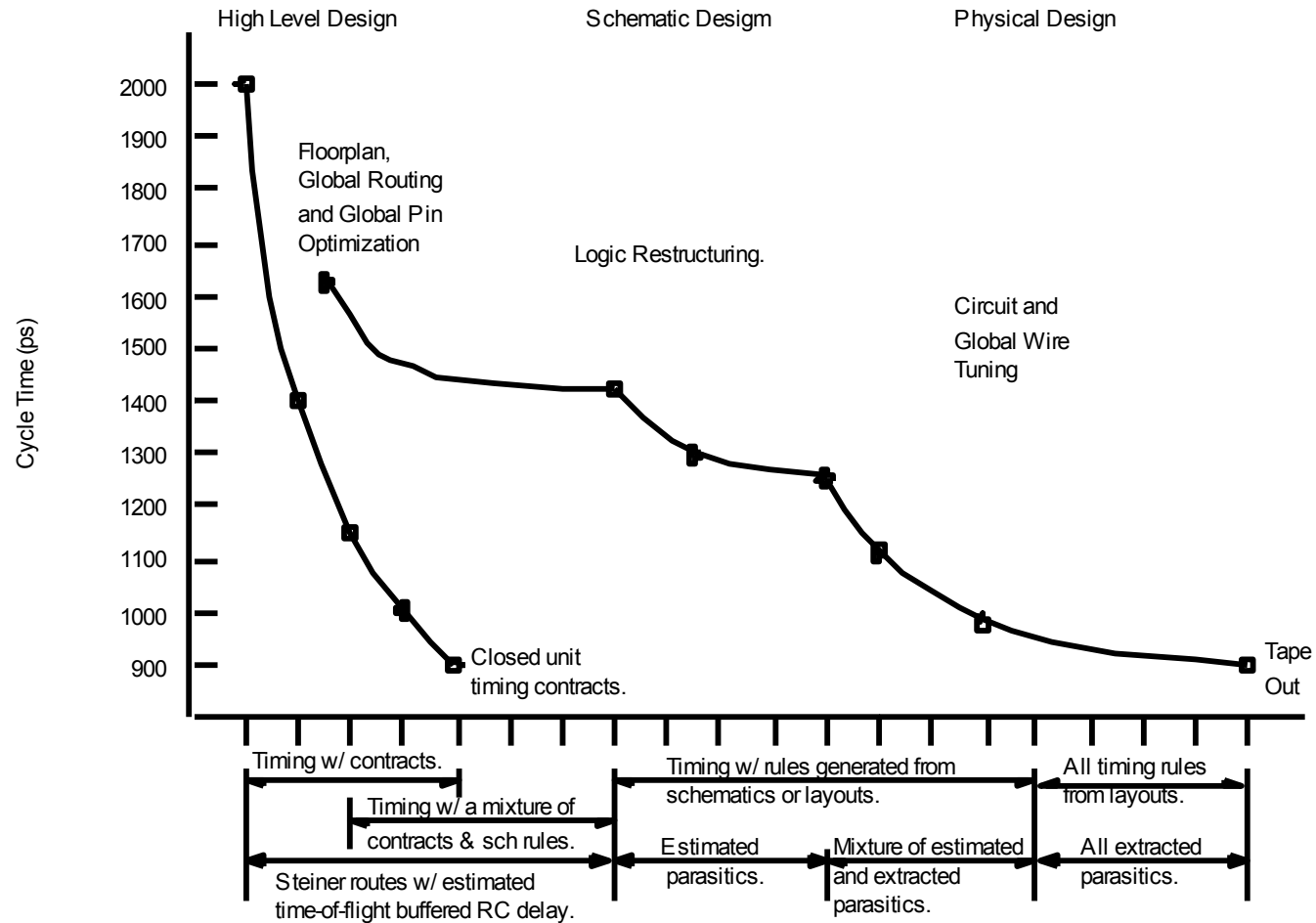

- **End result is a micro-architectural starting point that is known in advance to have an implementation that can meet the program goals for not just area but also timing**

- **Get designers thinking about physical implementation required to meet the various timing objectives while still in the micro-architectural design phase**

- **Give designers a methodology & process for:**
 - rapidly evaluating the micro-architectural and timing effects of chip physical design decisions (rapid design space exploration).
 - chip floor planning targeted at closing not just area but also all key timing requirements.

- **Simplified analysis compared to implementation phase**
 - **Using 1 PVT* late mode timing point**
 - Assume monotonic switching per gate (no MIS)
 - Some pessimism built into uncertainty

 - **Parasitic loads are estimated and based on placement**
 - During implementation phase the goal will be to use extracted parasitics

 - **Wires between blocks assume some max edge rate**
 - i.e., virtual repeaters, time of flight wire delay calculations

 - **All arrival and required times are absolute (class project)**
 - All launch/capture pairs assumed synchronous
 - Analysis performed without LCBs

* **Process/Voltage/Temperature**

EDP-TC Starting Point Data Requirements

- **Initial chip size, form factor and I/O requirements.**
- **Initial chip timing goals.**
- **Initial top level floorplan-able block list & functionality.**
- **Initial chip & top level floorplan-able block connectivity.**
- **For each floorplan-able block**
 - **initial sizes**
 - **initial form factors**
 - **initial pin positions**
 - **initial timing assertions**
- **These initial starting points normally evolve during the EDP-TC process.**

EDP-TC Methodology How-To

- **Methodology Overview**
- **Block Size Estimation (another lecture)**
- **Block Timing Assertions Generation**
 - How do you get the numbers
- **Delay Estimation**

Methodology Overview (Big Picture)

- **Determine chip I/O definition from architectural specification**
 - I/O placement (next levels of packaging & system considerations)
- **Determine initial cut at top level floorplan-able blocks from architectural and/or functional descriptions and specifications.**
- **Generate first pass top level netlist specifying interconnection of top level floorplan-able blocks and chip I/O's**
- **Estimate initial top level floorplan-able block sizes**
 - **Analyze the block's component parts**
 - Use prior implementations of similar functions as a starting point
 - Perform first pass logic realization on some sub-blocks
- **Estimate chip size**
 - Floorplan-able block area + wiring uplift (~25-30%)

- **Produce chip floorplans**
 - determine initial form factors
 - block attributes (memory cell)
 - connectivity (bus widths)
 - Wire-ability
- **Iterate on floor-plan to close area & timing constraints**
 - Given initial floor-plan, estimate timing of top level critical timing paths based on top level connectivity, block placement, and pin placements
 - Modify block form factor, placement, pin placement and architectural/functional description if required to improve timing and or area.
 - Changes to architectural specifications will yield updates to the number of blocks, their sizes and /or form factors, and the netlist (connectivity) of the top level blocks.
- **Done when you have an architectural specification and a floor-plan that achieves area and timing goals.**

Block Timing Assertions Generation

- **Block Timing Assertions - What Are They?**
- **Usage of Block Timing Assertions in EDP-TC.**
- **Clock Cycle Adjusts in Slack Calculations.**
- **Estimating Delays for Initial floorplans.**
- **How Timing Contracts (Block Assertions) Are used in the Implementation Phase of the Design.**

Block Timing Assertions --- What Are They?

■ Basic Block Timing Model

- Depicts timing information about paths in a particular block
 - **3 types of paths modeled in a block**
 - capture: block input to register
 - launch: register to block output
 - purely combinatorial: delay from block input to output

■ Basic Block Assertions

- Input Pin Required Arrival Times (RAT)
 - For each input pin on a block
 - latest time a signal can arrive at that pin and still get successfully captured in the register inside the block fed by that pin.
 - Calculated by: $RAT = \{AT(\text{clock @ register})\} - \{\text{Internal logic \& wire delay between pin and register}\} - \{\text{register setup requirement}\}$
 - combinatorial: RAT = Need to analyze entire path from register launch to register capture, along with combinatorial delay for the portion of the path inside this block.

Block Timing Assertions --- What Are They? (con't)



■ Basic Block Assertions (con't).

– Output Pin Arrival Times: (AT)

• For each input pin on a block

- latest time that a signal launched from a register inside the block that feeds the pin arrives at the pin.
 - Calculated by: $AT = \{AT(\text{clock@register})\} + \{\text{Internal logic \& wire delay between register and pin}\} + \{\text{register launch delay}\}$
- combinatorial: AT = same problem as combinatorial RAT described on preceding page.

– Block assertions determined by block alone except for purely combinatorial paths

- Preferable to eliminate if possible both wire feed-throughs & purely combinatorial paths from all top level blocks.
 - Want assertions & block timing properties to be floor-plan independent to enable rapid iteration.

Path Types Modelled in a Block

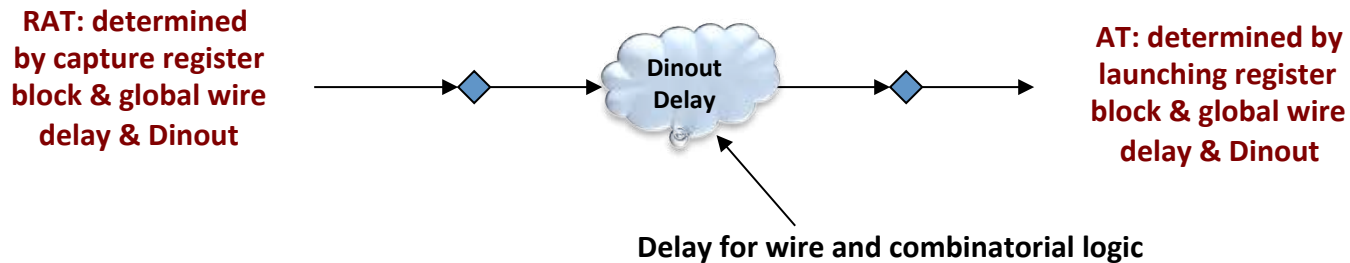
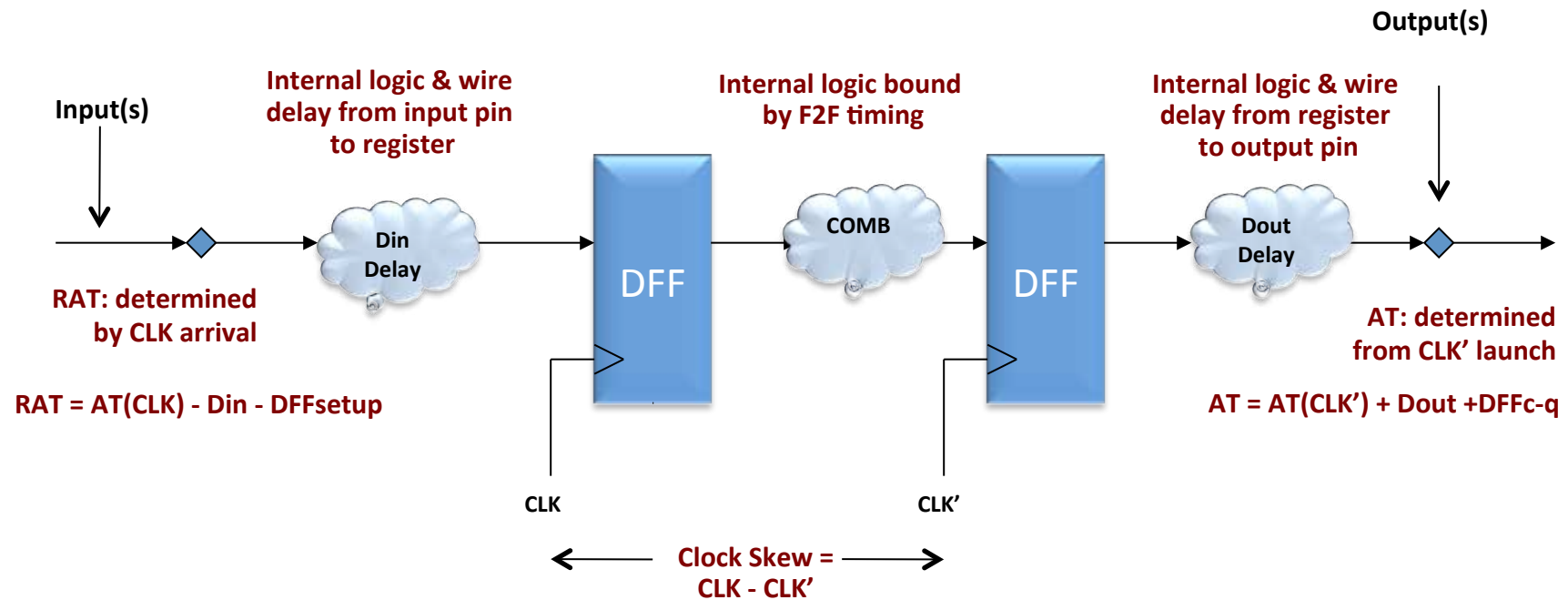

Usage of Block Timing Assertions in EDP-TC

- **Every pin of every block and the chip top level block has both an AT and a RAT.**
 - Connectivity determines which are combined to determine the slack (timing goodness) of a path.
- **Calculate the slack for a path sourced from one block and sunk in another.**
 - Avoid purely combinatorial paths and feed-throughs when possible
 - Avoid these at the full chip level
 - Slack calculation must consider phase of launching and capturing clocks in a path
 - all events derived from one cycle of the master clock (ignore multicycle paths for now)
 - no zero cycle setup paths exist
 - A cycle adjustment is made to this calculation when the leading edge of the master clock corresponds to the capture event of the path and the trailing edge corresponds to the launching event.
- **When all paths have slack ≥ 0 the block assertions constitute the Timing Contracts for each block.**

Assertion Generation for Combinatorial Paths

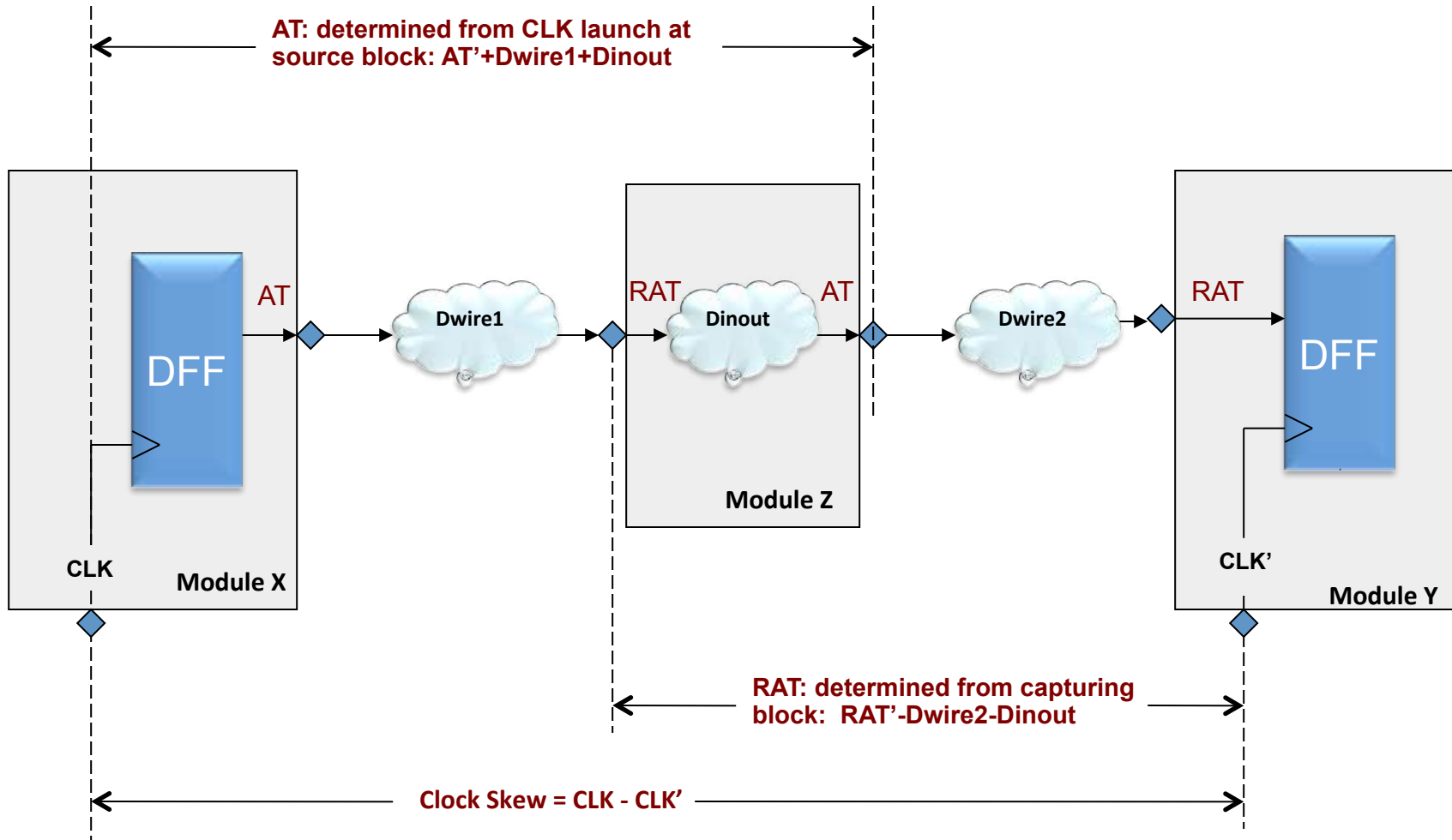

Usage of Block Timing Assertions

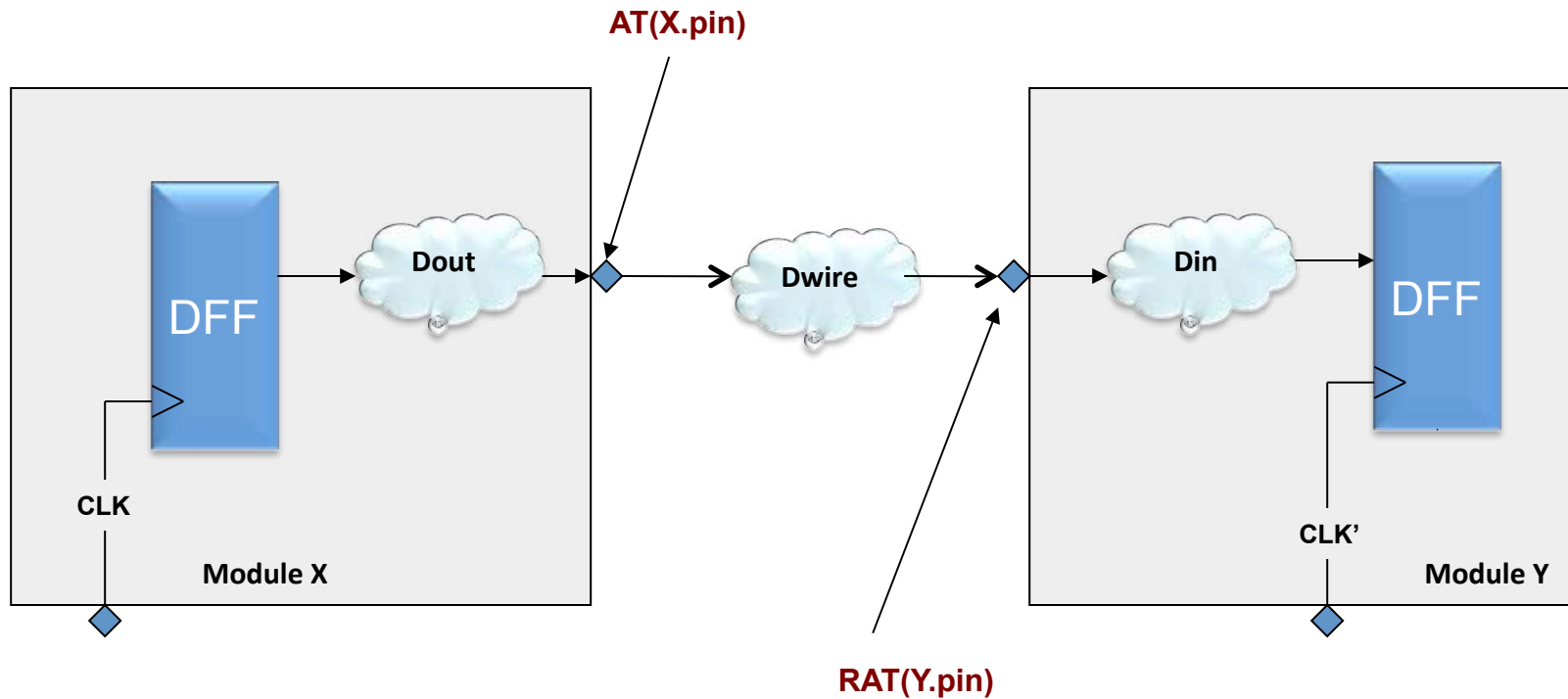

$$\text{Slack}(\text{path of X.CLK} \rightarrow \text{Y.pin}) = \text{RAT}(\text{Y.pin}) - \{ \text{AT}(\text{X.pin}) + \text{Dwire} \} + \text{Adjust}$$

How Timing Contracts are Used

- **Implementation phase starts at the end of EDP-TC.**
- **Given that EDP-TC closed chip timing at 0 slack, the Block Assertions are the Timing Contracts.**
- **Each block during design is timed stand alone against these contracts, or budgets. Affects synthesis (auto or manual).**
 - The RATs are now the assumed arrival times at the blocks inputs.
 - The ATs are now the assumed required times at the blocks outputs.
- **The contracts (assertions) are typically periodically updated from full chip timing runs to reflect actual design changes.**
 - It's important to continue to have a complete & consistent set of contracts that, if achieved by each block, yields a chip which meets the timing objective.

e.g., Contracts applied to block level timing

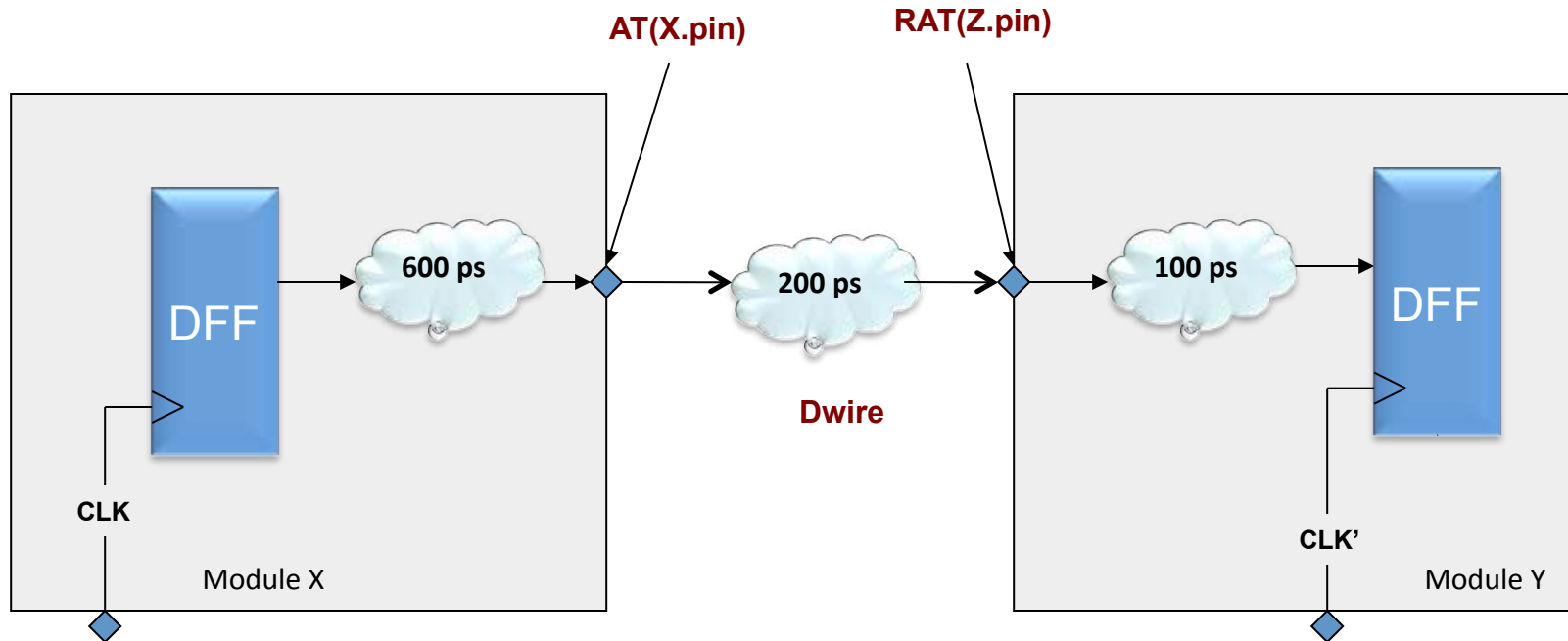

Module X
Level
Timing: $RAT(X.pin) = 600$

Module Y
Level
Timing: $AT(Y.pin) = T-100$

Wire Delay Estimation

- **Wire delay calculation & analysis overview.**
- **Elmore Delay**
- **Wire Delay Estimation Summary**
 - Time of Flight
 - Elmore Delay
 - Lumped RC product
 - RC Ladders

- **Simplified interconnect analysis.**
 - **Time of Flight (EDP-TC)**
 - **Simplest approach for EDP-TC.**
 - Given in picoseconds per millimetre
 - Assume optimal signal regeneration (buffering satisfies max allowable slew)
 - routing parasitic expressed as some delay per unit distance
 - determined for the process technology with spice simulations
 - assume certain levels of interconnect (parallel plate and fringing fields), coupling, and buffering
 - **Lumped RC product**
 - **Overly conservative for long wires.**
 - **RC Ladders.**
 - **Limiting Case, $R * C * (\text{Length}^2 / 2)$.**
 - **Elmore Delay Model.**
 - **Typically much less conservative from RC Ladders.**
 - **Effective estimates for Multi-Drop Nets.**
- **Save more complex analysis for implementation phase**
 - **shielding, inductance, 3D fields, etc.**
 - **poles/residues, AWE, 3D field solvers, etc**

Elmore RC Delay Calculation Model

- **More realistic RC delay than lumped RC for long nets.**
- **Able to handle multi-drop nets.**
- **The formula can be written from inspection of the RC tree.**
- **Calculable in linear time.**
- **Provable upper bound on RC delay.**
 - **Can still significantly overestimate RC delay in some cases.**

Elmore RC Delay Calculation Model (cont.)

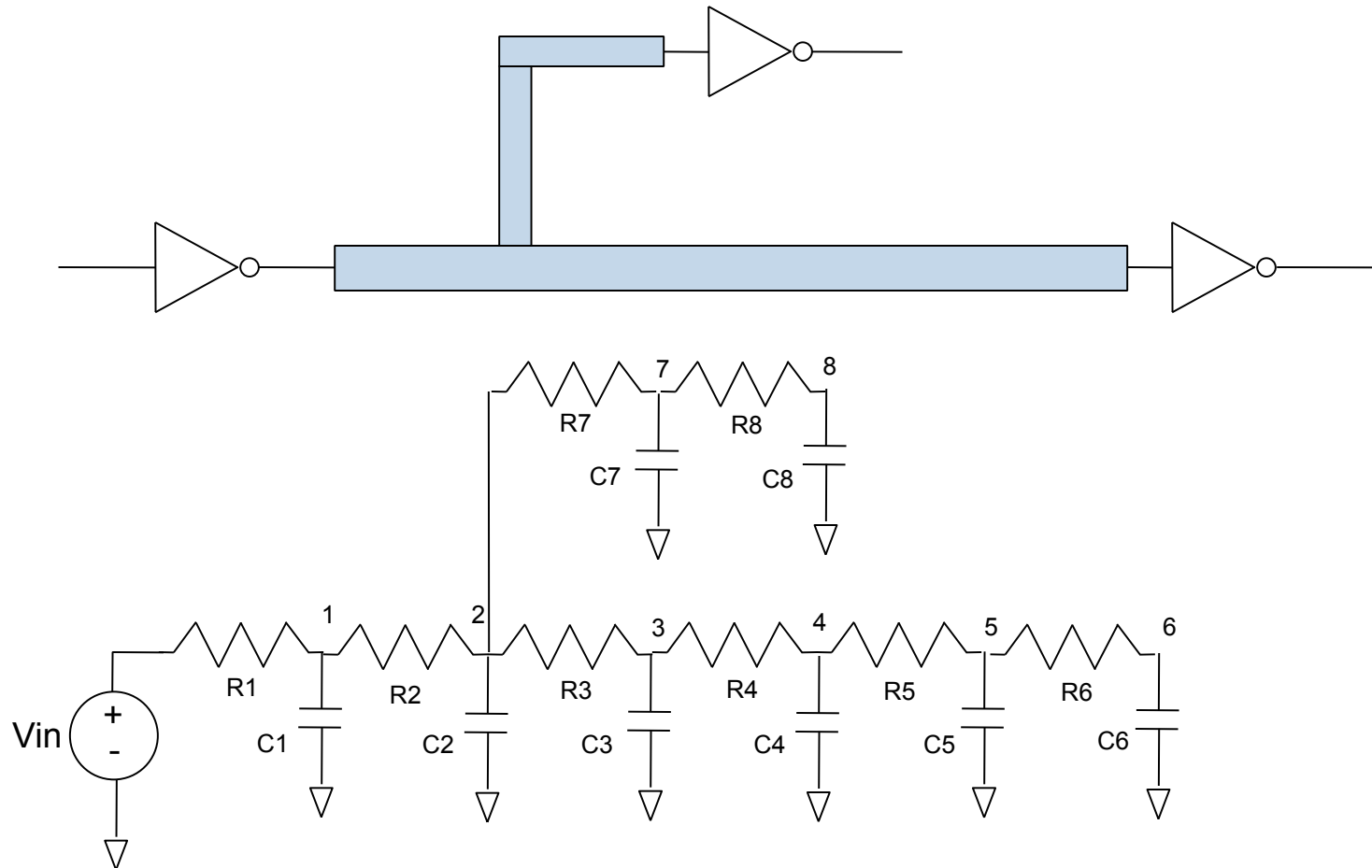

$$T_{d6} = R_1 C_1 + (R_1 + R_2)(C_2 + C_7 + C_8) + \left(\sum_{n=1}^3 R_n \right) (C_3) + \left(\sum_{n=1}^4 R_n \right) (C_4) + \left(\sum_{n=1}^5 R_n \right) (C_5) + \left(\sum_{n=1}^6 R_n \right) (C_6)$$

Wire Delay Estimation Summary

- **Time of flight is simplest and probably best for initial floor-plan timing.**
 - Use delay per wire length that considers best estimate for technology, routing layers, coupling, etc. as measured in early circuit analysis (spice)

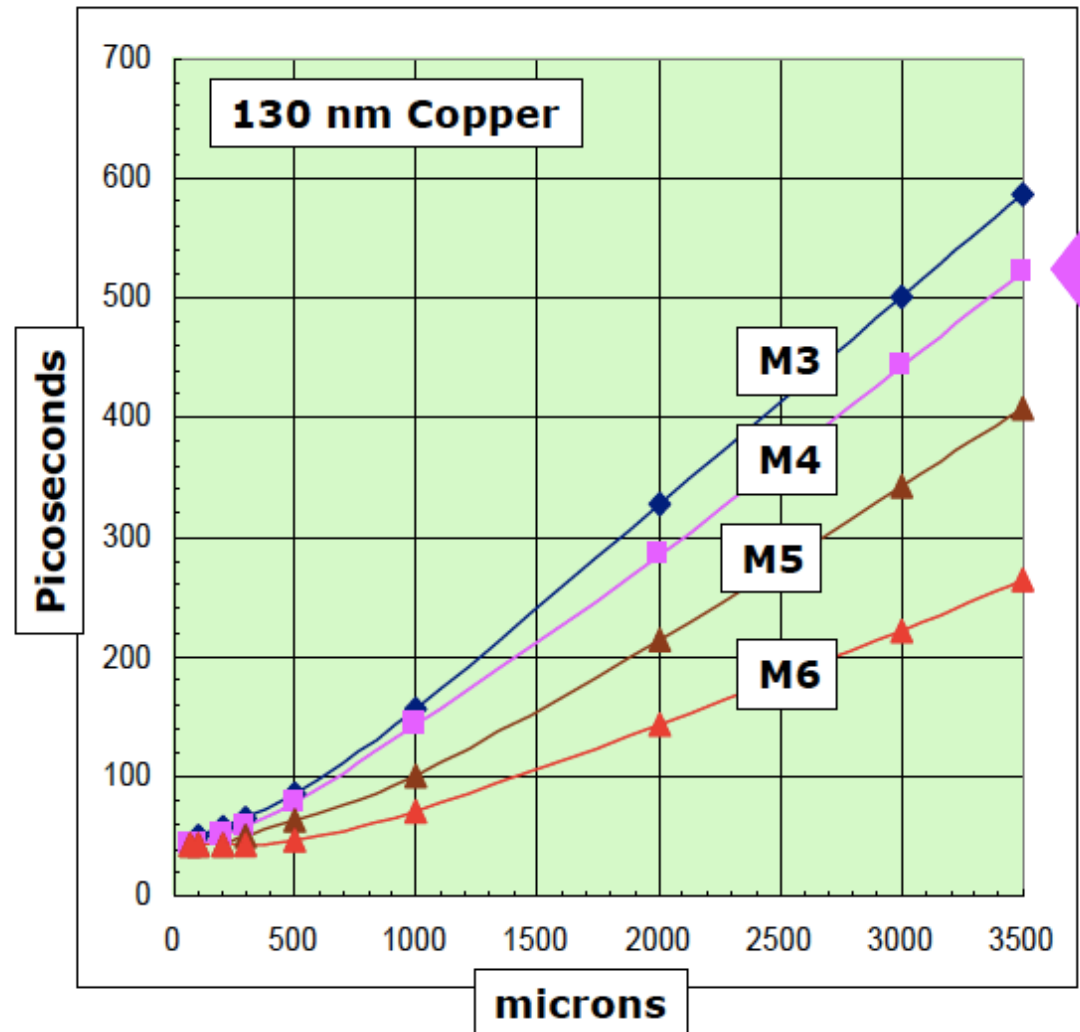

Wire Delay Estimation Summary (cont.)

- **Use Elmore Delay on selected nets as more estimated routing information becomes available**
 - Especially if the use of wide wires or upper level metal for low impedance wiring is required to close timing

Summary: EDP-TC End Products

- **What comes out of the EDP-TC process**
 - Floorplan that will meet basic timing constraints
 - Block size & shape (discussed in another lecture)
 - Pin positions on all blocks
 - Pass through's on all blocks
 - Timing contracts (assertions & constraints)