



OpenSPARC™ T1 Microarchitecture Specification

Sun Microsystems, Inc.
www.sun.com

Part No. 819-6650-10
August 2006, Revision A

Submit comments about this document at: <http://www.sun.com/hwdocs/feedback>

Copyright © 2006 Sun Microsystems, Inc., 4150 Network Circle, Santa Clara, California 95054, U.S.A. All rights reserved.

Sun Microsystems, Inc. has intellectual property rights relating to technology embodied in the product that is described in this document. In particular, and without limitation, these intellectual property rights may include one or more of the U.S. patents listed at <http://www.sun.com/patents> and one or more additional patents or pending patent applications in the U.S. and in other countries.

U.S. Government Rights - Commercial software. Government users are subject to the Sun Microsystems, Inc. standard license agreement and applicable provisions of the FAR and its supplements.

Use is subject to license terms.

This distribution may include materials developed by third parties.

Sun, Sun Microsystems, the Sun logo, Solaris, OpenSPARC T1 and UltraSPARC are trademarks or registered trademarks of Sun Microsystems, Inc. in the U.S. and other countries.

All SPARC trademarks are used under license and are trademarks or registered trademarks of SPARC International, Inc. in the U.S. and other countries. Products bearing SPARC trademarks are based upon architecture developed by Sun Microsystems, Inc.

UNIX is a registered trademark in the U.S. and other countries, exclusively licensed through X/Open Company, Ltd.

The Adobe logo is a registered trademark of Adobe Systems, Incorporated.

Products covered by and information contained in this service manual are controlled by U.S. Export Control laws and may be subject to the export or import laws in other countries. Nuclear, missile, chemical biological weapons or nuclear maritime end uses or end users, whether direct or indirect, are strictly prohibited. Export or reexport to countries subject to U.S. embargo or to entities identified on U.S. export exclusion lists, including, but not limited to, the denied persons and specially designated nationals lists is strictly prohibited.

DOCUMENTATION IS PROVIDED "AS IS" AND ALL EXPRESS OR IMPLIED CONDITIONS, REPRESENTATIONS AND WARRANTIES, INCLUDING ANY IMPLIED WARRANTY OF MERCHANTABILITY, FITNESS FOR A PARTICULAR PURPOSE OR NON-INFRINGEMENT, ARE DISCLAIMED, EXCEPT TO THE EXTENT THAT SUCH DISCLAIMERS ARE HELD TO BE LEGALLY INVALID.

Copyright © 2006 Sun Microsystems, Inc., 4150 Network Circle, Santa Clara, California 95054, Etats-Unis. Tous droits réservés.

Sun Microsystems, Inc. détient les droits de propriété intellectuelle relatifs à la technologie incorporée dans le produit qui est décrit dans ce document. En particulier, et ce sans limitation, ces droits de propriété intellectuelle peuvent inclure un ou plus des brevets américains listés à l'adresse <http://www.sun.com/patents> et un ou les brevets supplémentaires ou les applications de brevet en attente aux Etats - Unis et dans les autres pays.

L'utilisation est soumise aux termes de la Licence.

Cette distribution peut comprendre des composants développés par des tierces parties.

Sun, Sun Microsystems, le logo Sun, Solaris, OpenSPARC T1 et UltraSPARC sont des marques de fabrique ou des marques déposées de Sun Microsystems, Inc. aux Etats-Unis et dans d'autres pays.

Toutes les marques SPARC sont utilisées sous licence et sont des marques de fabrique ou des marques déposées de SPARC International, Inc. aux Etats-Unis et dans d'autres pays. Les produits portant les marques SPARC sont basés sur une architecture développée par Sun Microsystems, Inc.

UNIX est une marque déposée aux Etats-Unis et dans d'autres pays et licenciée exclusivement par X/Open Company, Ltd.

Le logo Adobe. est une marque déposée de Adobe Systems, Incorporated.

Les produits qui font l'objet de ce manuel d'entretien et les informations qu'il contient sont regis par la législation américaine en matière de contrôle des exportations et peuvent être soumis au droit d'autres pays dans le domaine des exportations et importations. Les utilisations finales, ou utilisateurs finaux, pour des armes nucléaires, des missiles, des armes biologiques et chimiques ou du nucléaire maritime, directement ou indirectement, sont strictement interdites. Les exportations ou réexportations vers des pays sous embargo des Etats-Unis, ou vers des entités figurant sur les listes d'exclusion d'exportation américaines, y compris, mais de manière non exclusive, la liste de personnes qui font objet d'un ordre de ne pas participer, d'une façon directe ou indirecte, aux exportations des produits ou des services qui sont régis par la législation américaine en matière de contrôle des exportations et la liste de ressortissants spécifiquement désignés, sont rigoureusement interdites.

LA DOCUMENTATION EST FOURNIE "EN L'ETAT" ET TOUTES AUTRES CONDITIONS, DECLARATIONS ET GARANTIES EXPRESSES OU TACITES SONT FORMELLEMENT EXCLUES, DANS LA MESURE AUTORISEE PAR LA LOI APPLICABLE, Y COMPRIS NOTAMMENT TOUTE GARANTIE IMPLICITE RELATIVE A LA QUALITE MARCHANDE, A L'APTITUDE A UNE UTILISATION PARTICULIERE OU A L'ABSENCE DE CONTREFACON.



Contents

Preface xix

1. OpenSPARC T1 Overview 1-1

1.1 Introducing the OpenSPARC T1 Processor 1-1

1.2 Functional Description 1-2

1.3 OpenSPARC T1 Components 1-4

1.3.1 SPARC Core 1-4

1.3.1.1 Instruction Fetch Unit 1-6

1.3.1.2 Execution Unit 1-6

1.3.1.3 Load/Store Unit 1-6

1.3.1.4 Floating-Point Frontend Unit 1-7

1.3.1.5 Trap Logic Unit 1-7

1.3.1.6 Stream Processing Unit 1-8

1.3.2 CPU-Cache Crossbar 1-8

1.3.3 Floating-Point Unit 1-9

1.3.4 L2-Cache 1-10

1.3.5 DRAM Controller 1-11

1.3.6 I/O Bridge 1-11

1.3.7 J-Bus Interface 1-11

1.3.8 Serial System Interface 1-12

- 1.3.9 Electronic Fuse 1–12

- 2. SPARC Core 2–1**
 - 2.1 SPARC Core Overview and Terminology 2–2
 - 2.2 SPARC Core I/O Signal List 2–5
 - 2.3 Instruction Fetch Unit 2–6
 - 2.3.1 SPARC Core Pipeline 2–7
 - 2.3.2 Instruction Fetch 2–8
 - 2.3.3 Instruction Registers and Program Counter Registers 2–9
 - 2.3.4 Level 1 Instruction Cache 2–9
 - 2.3.5 I-Cache Fill Path 2–10
 - 2.3.6 Alternate Space Identifier Accesses, I-Cache Line Invalidations, and Built-In Self-Test Accesses to the I-Cache 2–11
 - 2.3.7 I-Cache Miss Path 2–12
 - 2.3.8 Windowed Integer Register File 2–13
 - 2.3.9 Instruction Table Lookaside Buffer 2–15
 - 2.3.10 Thread Selection Policy 2–15
 - 2.3.11 Thread States 2–16
 - 2.3.12 Thread Scheduling 2–18
 - 2.3.13 Rollback Mechanism 2–19
 - 2.3.14 Instruction Decode 2–20
 - 2.3.15 Instruction Fetch Unit Interrupt Handling 2–20
 - 2.3.16 Error Checking and Logging 2–21
 - 2.4 Load Store Unit 2–21
 - 2.4.1 LSU Pipeline 2–22
 - 2.4.2 Data Flow 2–22
 - 2.4.3 Level 1 Data Cache (D-Cache) 2–23
 - 2.4.4 Data Translation Lookaside Buffer 2–24
 - 2.4.5 Store Buffer 2–25

2.4.6	Load Miss Queue	2-26
2.4.7	Processor to Crossbar Interface Arbiter	2-26
2.4.8	Data Fill Queue	2-27
2.4.9	ASI Queue and Bypass Queue	2-27
2.4.10	Alternate Space Identifier Handling in the Load Store Unit	2-28
2.4.11	Support for Atomic Instructions (CAS, SWAP, LDSTUB)	2-28
2.4.12	Support for MEMBAR Instructions	2-29
2.4.13	Core-to-Core Interrupt Support	2-29
2.4.14	Flush Instruction Support	2-29
2.4.15	Prefetch Instruction Support	2-30
2.4.16	Floating-Point BLK-LD and BLK-ST Instructions Support	2-30
2.4.17	Integer BLK-INIT Loads and Stores Support	2-31
2.4.18	STRM Load and STRM Store Instruction Support	2-31
2.4.19	Test Access Port Controller Accesses and Forward Packets Support	2-31
2.4.20	SPARC Core Pipeline Flush Support	2-32
2.4.21	LSU Error Handling	2-32
2.5	Execution Unit	2-33
2.6	Floating-Point Frontend Unit	2-35
2.6.1	Functional Description of the FFU	2-35
2.6.2	Floating-Point Register File	2-36
2.6.3	FFU Control (FFU_CTL)	2-36
2.6.4	FFU Data-Path (FFU_DP)	2-37
2.6.5	FFU VIS (FFU_DP)	2-37
2.7	Multiplier Unit	2-37
2.7.1	Functional Description of the MUL	2-37
2.8	Stream Processing Unit	2-38
2.8.1	ASI Registers for the SPU	2-38
2.8.2	Data Flow of Modular Arithmetic Operations	2-40

- 2.8.3 Modular Arithmetic Memory (MA Memory) 2–40
- 2.8.4 Modular Arithmetic Operations 2–41
- 2.9 Memory Management Unit 2–43
 - 2.9.1 The Role of MMU in Virtualization 2–44
 - 2.9.2 Data Flow in MMU 2–45
 - 2.9.3 Structure of Translation Lookaside Buffer 2–45
 - 2.9.4 MMU ASI Operations 2–47
 - 2.9.5 Specifics on TLB Write Access 2–48
 - 2.9.6 Specifics on TLB Read Access 2–48
 - 2.9.7 Translation Lookaside Buffer Demap 2–48
 - 2.9.8 TLB Auto-Demap Specifics 2–49
 - 2.9.9 TLB Entry Replacement Algorithm 2–49
 - 2.9.10 TSB Pointer Construction 2–49
- 2.10 Trap Logic Unit 2–50
 - 2.10.1 Architecture Registers in the Trap Logic Unit 2–52
 - 2.10.2 Trap Types 2–53
 - 2.10.3 Trap Flow 2–55
 - 2.10.4 Trap Program Counter Construction 2–57
 - 2.10.5 Interrupts 2–57
 - 2.10.6 Interrupt Flow 2–58
 - 2.10.7 Interrupt Behavior and Interrupt Masking 2–61
 - 2.10.8 Privilege Levels and States of a Thread 2–61
 - 2.10.9 Trap Modes Transition 2–62
 - 2.10.10 Thread States Transition 2–63
 - 2.10.11 Content Construction for Processor State Registers 2–64
 - 2.10.12 Trap Stack 2–65
 - 2.10.13 Trap (Tcc) Instructions 2–66
 - 2.10.14 Trap Level 0 Trap for Hypervisor 2–66

2.10.15 Performance Control Register and Performance Instrumentation Counter 2-66

3. CPU-Cache Crossbar 3-1

- 3.1 Functional Description 3-1
 - 3.1.1 CPU-Cache Crossbar Overview 3-1
 - 3.1.2 CCX Packet Delivery 3-2
 - 3.1.3 Processor-Cache Crossbar Packet Delivery 3-3
 - 3.1.4 Cache-Processor Crossbar Packet Delivery 3-4
 - 3.1.5 CPX and PCX Packet Formats 3-5
- 3.2 CCX I/O List 3-9
- 3.3 CCX Timing Diagrams 3-13
- 3.4 PCX Internal Blocks Functional Description 3-17
 - 3.4.1 PCX Overview 3-17
 - 3.4.2 PCX Arbiter Data Flow 3-18
 - 3.4.3 PCX Arbiter Control Flow 3-19
- 3.5 CPX Internal Blocks Functional Description 3-20
 - 3.5.1 CPX Overview 3-20
 - 3.5.2 CPX Arbiters 3-20

4. Level 2 Cache 4-1

- 4.1 L2-Cache Functional Description 4-1
 - 4.1.1 L2-Cache Overview 4-1
 - 4.1.2 L2-Cache Single Bank Functional Description 4-2
 - 4.1.2.1 Arbiter 4-4
 - 4.1.2.2 L2 Tag 4-4
 - 4.1.2.3 L2 VUAD States 4-4
 - 4.1.2.4 L2 Data (scdata) 4-5
 - 4.1.2.5 Input Queue 4-5
 - 4.1.2.6 Output Queue 4-6

- 4.1.2.7 Snoop Input Queue 4–6
- 4.1.2.8 Miss Buffer 4–6
- 4.1.2.9 Fill Buffer 4–7
- 4.1.2.10 Writeback Buffer 4–8
- 4.1.2.11 Remote DMA Write Buffer 4–8
- 4.1.2.12 L2-Cache Directory 4–8
- 4.1.3 L2-Cache Pipeline 4–9
 - 4.1.3.1 L2-Cache Transaction Types 4–9
 - 4.1.3.2 L2-Cache Pipeline Stages 4–10
- 4.1.4 L2-Cache Instruction Descriptions 4–12
 - 4.1.4.1 Loads 4–12
 - 4.1.4.2 Ifetch 4–12
 - 4.1.4.3 Stores 4–13
 - 4.1.4.4 Atomics 4–13
 - 4.1.4.5 J-Bus Interface Instructions 4–14
 - 4.1.4.6 Eviction 4–16
 - 4.1.4.7 Fill 4–16
 - 4.1.4.8 Other Instructions 4–16
- 4.1.5 L2-Cache Memory Coherency and Instruction Ordering 4–17
- 4.2 L2-Cache I/O LIST 4–18

5. Input/Output Bridge 5–1

- 5.1 Functional Description 5–1
 - 5.1.1 IOB Interfaces 5–2
 - 5.1.2 UCB Interface 5–4
 - 5.1.2.1 UCB Request and Acknowledge Packets 5–4
 - 5.1.2.2 UCB Interrupt Packet 5–6
 - 5.1.2.3 UCB Interface Packet Example 5–6
 - 5.1.3 IOB Address Map 5–7

5.1.4	IOB Block Diagram	5-8
5.1.5	IOB Transactions	5-9
5.1.6	IOB Interrupts	5-10
5.1.7	IOB Miscellaneous Functionality	5-11
5.1.8	IOB Errors	5-11
5.1.9	Debug Ports	5-12
5.2	I/O Bridge Signal List	5-12
6.	J-Bus Interface	6-1
6.1	Functional Description	6-1
6.1.1	J-Bus Requests to the L2-Cache	6-3
6.1.1.1	Write Requests to the L2-Cache	6-3
6.1.1.2	Read Requests to the L2-Cache	6-4
6.1.1.3	Flow Control	6-4
6.1.2	I/O Buffer Requests to the J-Bus	6-4
6.1.3	J-Bus Interrupt Requests to the IOB	6-5
6.1.4	J-Bus Interface Details	6-5
6.1.5	Debug Port to the J-Bus	6-6
6.1.6	J-Bus Internal Arbitration	6-6
6.1.7	Error Handling in JBI	6-7
6.1.8	Performance Counters	6-7
6.2	I/O Signal list	6-8
7.	Floating-Point Unit	7-1
7.1	Functional Description	7-1
7.1.1	Floating-Point Instructions	7-4
7.1.2	FPU Input FIFO Queue	7-5
7.1.3	FPU Output Arbitration	7-6
7.1.4	Floating-Point Adder	7-6

- 7.1.5 Floating-Point Multiplier 7–7
- 7.1.6 Floating-Point Divider 7–8
- 7.1.7 FPU Power Management 7–9
- 7.1.8 Floating-Point State Register Exceptions and Traps 7–10
 - 7.1.8.1 Overflow and Underflow 7–12
 - 7.1.8.2 IEEE Exception List 7–13
- 7.2 I/O Signal list 7–15

8. DRAM Controller 8–1

- 8.1 Functional Description 8–1
 - 8.1.1 Arbitration Priority 8–3
 - 8.1.2 DRAM Controller State Diagrams 8–4
 - 8.1.3 Programmable Features 8–5
 - 8.1.4 Errors 8–6
 - 8.1.5 Repeatability and Visibility 8–6
 - 8.1.6 DDR-II Addressing 8–7
 - 8.1.7 DDR-II Supported Features 8–8
- 8.2 I/O Signal List 8–9

9. Error Handling 9–1

- 9.1 Error Handling Overview 9–1
 - 9.1.1 Error Reporting and Logging 9–2
 - 9.1.2 Error Traps 9–2
- 9.2 SPARC Core Errors 9–3
 - 9.2.1 SPARC Core Error Registers 9–3
 - 9.2.2 SPARC Core Error Protection 9–4
 - 9.2.3 SPARC Core Error Correction 9–4
- 9.3 L2-Cache Errors 9–5
 - 9.3.1 L2-Cache Error Registers 9–5

9.3.2	L2-Cache Error Protection	9-6
9.3.3	L2-Cache Correctable Errors	9-6
9.3.4	L2-Cache Uncorrectable Errors	9-7
9.4	DRAM Errors	9-8
9.4.1	DRAM Error Registers	9-8
9.4.2	DRAM Error Protection	9-9
9.4.3	DRAM Correctable Errors	9-9
9.4.4	DRAM Uncorrectable and Addressing Errors	9-9
10.	Clocks and Resets	10-1
10.1	Functional Description	10-1
10.1.1	OpenSPARC T1 Processor Clocks	10-1
10.1.1.1	Phase-Locked Loop	10-3
10.1.1.2	Clock Dividers	10-4
10.1.1.3	Clock Domain Crossings	10-5
10.1.1.4	Clock Gating	10-7
10.1.1.5	Clock Stop	10-7
10.1.1.6	Clock Stretch	10-8
10.1.1.7	Clock <i>n</i> -Step	10-8
10.1.1.8	Clock Signal Distribution	10-8
10.1.2	OpenSPARC T1 Processor Resets	10-10
10.1.2.1	Power-On Reset (PWRON_RST_L)	10-10
10.1.2.2	J-Bus Reset (J_RST_L)	10-11
10.1.2.3	Reset Sequence	10-11
10.1.2.4	Debug Initialization	10-15
10.2	I/O Signal list	10-15

Figures

- [FIGURE 1-1](#) OpenSPARC T1 Processor Block Diagram 1–3
- [FIGURE 1-2](#) SPARC Core Pipeline 1–5
- [FIGURE 1-3](#) CCX Block Diagram 1–9
- [FIGURE 2-1](#) SPARC Core Block Diagram 2–2
- [FIGURE 2-2](#) Physical Location of Functional Units on an OpenSPARC T1 SPARC Core 2–3
- [FIGURE 2-3](#) Virtualization of Software Layers 2–4
- [FIGURE 2-4](#) SPARC Core Pipeline and Support Structures 2–7
- [FIGURE 2-5](#) Frontend of the SPARC Core Pipeline 2–8
- [FIGURE 2-6](#) I-Cache Fill Path 2–10
- [FIGURE 2-7](#) I-Cache Miss Path 2–12
- [FIGURE 2-8](#) IARF and IWRF File Structure 2–14
- [FIGURE 2-9](#) Basic Transition of Non-Active States 2–16
- [FIGURE 2-10](#) Thread State Transition of an Active Thread 2–17
- [FIGURE 2-11](#) State Transition for a Thread in Speculative States 2–18
- [FIGURE 2-12](#) Rollback Mechanism Pipeline Graph 2–19
- [FIGURE 2-13](#) LSU Pipeline Graph 2–22
- [FIGURE 2-14](#) LSU Data Flow Concept 2–23
- [FIGURE 2-15](#) Execution Unit Diagram 2–33
- [FIGURE 2-16](#) Shifter Block Diagram 2–34
- [FIGURE 2-17](#) ALU Block Diagram 2–34

FIGURE 2-18	IDIV Block Diagram	2–35
FIGURE 2-19	Top-Level FFU Block Diagram	2–36
FIGURE 2-20	Multiplexor (MUL) Block Diagram	2–37
FIGURE 2-21	Layout of MA_ADDR Register Bit Fields	2–38
FIGURE 2-22	Data Flow of Modular Arithmetic Operations	2–40
FIGURE 2-23	State Transition Diagram Illustrating MA Operations	2–41
FIGURE 2-24	Multiply Function Result Generation Sequence Pipeline Diagram	2–43
FIGURE 2-25	MMU and TLBs Relationship	2–44
FIGURE 2-26	Virtualization Diagram	2–44
FIGURE 2-27	Translation Lookaside Buffer Structure	2–46
FIGURE 2-28	TLU Role With Respect to All Other Backlogs in a SPARC Core	2–51
FIGURE 2-29	Trap Flow Sequence	2–55
FIGURE 2-30	Trap Flow With Respect to the Hardware Blocks	2–56
FIGURE 2-31	Flow of Hardware and Vector Interrupts	2–58
FIGURE 2-32	Flow of Reset or Idle or Resume Interrupts	2–59
FIGURE 2-33	Flow of Software and Timer Interrupts	2–60
FIGURE 2-34	Trap Modes Transition	2–62
FIGURE 2-35	Thread State Transition	2–63
FIGURE 2-36	PCR and PIC Layout	2–67
FIGURE 3-1	CPU Cache-Crossbar (CCX) Interface	3–2
FIGURE 3-2	Processor Cache-Crossbar (PCX) Interface	3–2
FIGURE 3-3	Cache-Processor Crossbar (CPX) Interface	3–4
FIGURE 3-4	PCX Packet Transfer Timing – One Packet Request	3–13
FIGURE 3-5	PCX Packet Transfer Timing – Two-Packet Request	3–14
FIGURE 3-6	CPX Packet Transfer Timing Diagram – One Packet Request	3–15
FIGURE 3-7	CPX Packet Transfer Timing Diagram – Two Packet Request	3–16
FIGURE 3-8	PCX and CPX Internal Blocks	3–17
FIGURE 3-9	Data Flow in PCX Arbiter	3–18
FIGURE 3-10	Control Flow in PCX Arbiter	3–19
FIGURE 4-1	Flow Diagram and Interfaces for an L2-Cache Bank	4–3

FIGURE 5-1	I/OB Interfaces	5-2
FIGURE 5-2	I/OB UCB Interface to and From the Cluster	5-4
FIGURE 5-3	I/OB Internal Block Diagram	5-8
FIGURE 6-1	JBI Functional Block Diagram	6-2
FIGURE 7-1	FPU Functional Block Diagram	7-2
FIGURE 8-1	DDR-II DRAM Controller Functional Block Diagram	8-2
FIGURE 8-2	DDR-II DRAM Controller Top-Level State Diagram	8-4
FIGURE 8-3	DIMM Scheduler State Diagram	8-5
FIGURE 10-1	Clock and Reset Functional Block Diagram	10-2
FIGURE 10-2	PLL Functional Block Diagram	10-3
FIGURE 10-3	Clock Divider Block Diagram	10-4
FIGURE 10-4	Sync Pulses Waveforms	10-6
FIGURE 10-5	Clock Signal Distribution	10-9

Tables

TABLE 2-1	SPARC Core Terminology	2-4
TABLE 2-2	SPARC Core I/O Signal List	2-5
TABLE 2-3	Modular Arithmetic Operations	2-39
TABLE 2-4	Error Handling Behavior	2-42
TABLE 2-5	Supported OpenSPARC T1 Trap Types	2-54
TABLE 2-6	Privilege Levels and Thread States	2-61
TABLE 3-1	CPX Packet Format – Part 1	3-5
TABLE 3-2	CPX Packet Format – Part 2	3-6
TABLE 3-3	PCX Packet Format – Part 1	3-7
TABLE 3-4	PCX Packet Format – Part 2	3-8
TABLE 3-5	CCX I/O Signal List	3-9
TABLE 4-1	SCDATA I/O Signal List	4-18
TABLE 4-2	SCBUF I/O Signal List	4-19
TABLE 4-3	SCTAG I/O Signal List	4-21
TABLE 5-1	UCB interfaces to Clusters	5-3
TABLE 5-2	UCB Request/Acknowledge Packet format	5-4
TABLE 5-3	UCB Request/ACK Packet Types	5-5
TABLE 5-4	UCB Data Size	5-5
TABLE 5-5	UCB Interrupt Packet Format	5-6
TABLE 5-6	UCB Interrupt Packet Types	5-6

TABLE 5-7	UCB No Payload Over an 8-Bit Interface Without Stalls	5–6
TABLE 5-8	UCB No Payload Over an 8-Bit Interface With Stalls	5–7
TABLE 5-9	IOB Address Map	5–7
TABLE 5-10	I/O Bridge I/O Signal List	5–12
TABLE 6-1	JBI I/O Signal List	6–8
TABLE 7-1	OpenSPARC T1 FPU Feature Summary	7–3
TABLE 7-2	SPARC V9 Single and Double Precision FPop Instruction Set	7–4
TABLE 7-3	FPA Datapath Stages	7–7
TABLE 7-4	FPM Datapath Stages	7–8
TABLE 7-5	FPD Datapath Stages	7–9
TABLE 7-6	IEEE Exception Cases	7–13
TABLE 7-7	FPU I/O Signal List	7–15
TABLE 8-1	DDR-II Addressing	8–7
TABLE 8-2	Physical Address to DIMM Address Decoding	8–7
TABLE 8-3	DDR-II Commands Used by OpenSPARC T1 Processor	8–8
TABLE 8-4	DRAM Controller I/O Signal List	8–9
TABLE 9-1	Error Protection for SPARC Memories	9–4
TABLE 9-2	Error Protection for L2-Cache Memories	9–6
TABLE 10-1	Clock Domain Dividers	10–5
TABLE 10-2	CTU I/O Signal List	10–15

Preface

This *OpenSPARC T1 Microarchitecture Specification* includes detailed functional descriptions of the core OpenSPARC™ T1 processor components. This manual also provides the I/O signal list for each component. This processor is the first chip multiprocessor that fully implements the Sun™ Throughput Computing initiative.

How This Document Is Organized

[Chapter 1](#) introduces the processor and provides a brief overview of each processor component.

[Chapter 2](#) provides a detailed description of the functional units of a SPARC® Core.

[Chapter 3](#) describes the CPU-cache crossbar (CCX) unit and includes detailed CCX block and timing diagrams.

[Chapter 4](#) provides a functional description of the L2-cache and describes the L2-cache pipeline and instructions.

[Chapter 5](#) describes the processor's input/output bridge (IOB).

[Chapter 6](#) gives a functional description of the J-Bus interface (JBI) block.

[Chapter 7](#) provides a functional description of the floating-point unit (FPU).

[Chapter 8](#) describes the dynamic random access memory (DRAM) controller.

[Chapter 9](#) provides a detailed overview of the processor's error handling mechanisms.

[Chapter 10](#) gives a functional description of the processor's clock and test unit (CTU).

Using UNIX Commands

This document might not contain information about basic UNIX® commands and procedures such as shutting down the system, booting the system, and configuring devices. Refer to the following for this information:

- Software documentation that you received with your system
- Solaris™ Operating System documentation, which is at:

<http://docs.sun.com>

Shell Prompts

Shell	Prompt
C shell	<i>machine-name%</i>
C shell superuser	<i>machine-name#</i>
Bourne shell and Korn shell	\$
Bourne shell and Korn shell superuser	#

Typographic Conventions

Typeface ¹	Meaning	Examples
AaBbCc123	The names of commands, files, and directories; on-screen computer output	Edit your <code>.login</code> file. Use <code>ls -a</code> to list all files. <code>% You have mail.</code>
AaBbCc123	What you type, when contrasted with on-screen computer output	<code>% su</code> Password:
<i>AaBbCc123</i>	Book titles, new words or terms, words to be emphasized. Replace command-line variables with real names or values.	Read Chapter 6 in the <i>User's Guide</i> . These are called <i>class</i> options. You <i>must</i> be superuser to do this. To delete a file, type <code>rm filename</code> .

¹ The settings on your browser might differ from these settings.

Related Documentation

The documents listed as online or download are available at:

<http://www.opensparc.net/>

Application	Title	Part Number	Format	Location
OpenSPARC T1 instruction set	<i>UltraSPARC® Architecture 2005 Specification</i>	950-4895	PDF	Online
OpenSPARC T1 processor's internal registers	<i>UltraSPARC T1 Supplement to the UltraSPARC Architecture 2005</i>	819-3404	PDF	Online
OpenSPARC T1 megacells	<i>OpenSPARC T1 Processor Megacell Specification</i>	819-5016	PDF	Download
OpenSPARC T1 signal pin list	<i>OpenSPARC T1 Processor Datasheet</i>	819-5015	PDF	Download
OpenSPARC T1 microarchitecture	<i>OpenSPARC T1 Microarchitecture Specification</i>	819-6650	PDF	Download
OpenSPARC T1 processor J-Bus and SSI interfaces	<i>OpenSPARC T1 Processor External Interface Specification</i>	819-5014	PDF	Download

Documentation, Support, and Training

Sun Function	URL
OpenSPARC T1	http://www.opensparc.net/
Documentation	http://www.sun.com/documentation/
Support	http://www.sun.com/support/
Training	http://www.sun.com/training/

Third-Party Web Sites

Sun is not responsible for the availability of third-party web sites mentioned in this document. Sun does not endorse and is not responsible or liable for any content, advertising, products, or other materials that are available on or through such sites or resources. Sun will not be responsible or liable for any actual or alleged damage or loss caused by or in connection with the use of or reliance on any such content, goods, or services that are available on or through such sites or resources.

OpenSPARC T1 Overview

This chapter contains the following topics:

- [Section 1.1, “Introducing the OpenSPARC T1 Processor” on page 1-1](#)
- [Section 1.2, “Functional Description” on page 1-2](#)
- [Section 1.3, “OpenSPARC T1 Components” on page 1-4](#)

1.1 Introducing the OpenSPARC T1 Processor

The OpenSPARC T1 processor is the first chip multiprocessor that fully implements the Sun Throughput Computing Initiative. The OpenSPARC T1 processor is a highly integrated processor that implements the 64-bit SPARC V9 architecture. This processor targets commercial applications such as application servers and database servers.

The OpenSPARC T1 processor contains eight SPARC® processor cores, which each have full hardware support for four threads. Each SPARC core has an instruction cache, a data cache, and a fully associative instruction and data translation lookaside buffers (TLB). The eight SPARC cores are connected through a crossbar to an on-chip unified level 2 cache (L2-cache).

The four on-chip dynamic random access memory (DRAM) controllers directly interface to the double data rate-synchronous DRAM (DDR2 SDRAM). Additionally, there is an on-chip J-Bus controller that provides an interconnect between the OpenSPARC T1 processor and the I/O subsystem.

1.2 Functional Description

The features of the OpenSPARC T1 processor include:

- 8 SPARC V9 CPU cores, with 4 threads per core, for a total of 32 threads
- 132 Gbytes/sec crossbar interconnect for on-chip communication
- 16 Kbytes of primary (Level 1) instruction cache per CPU core
- 8 Kbytes of primary (Level 1) data cache per CPU core
- 3 Mbytes of secondary (Level 2) cache – 4 way banked, 12 way associative shared by all CPU cores
- 4 DDR-II DRAM controllers – 144-bit interface per channel, 25 GBytes/sec peak total bandwidth
- IEEE 754 compliant floating-point unit (FPU), shared by all CPU cores
- External interfaces:
 - J-Bus interface (JBI) for I/O – 2.56 Gbytes/sec peak bandwidth, 128-bit multiplexed address/data bus
 - Serial system interface (SSI) for boot PROM

FIGURE 1-1 shows a block diagram of the OpenSPARC T1 processor illustrating the various interfaces and integrated components of the chip.

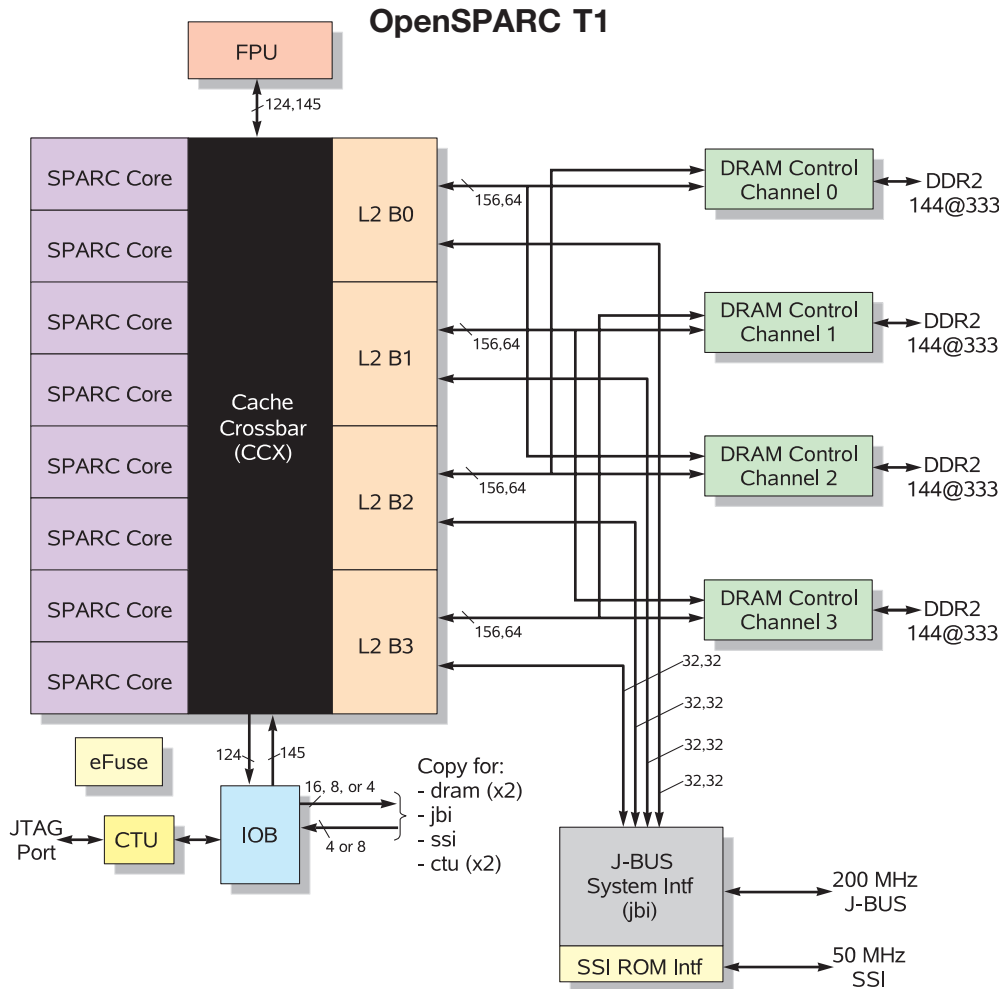

Notes:

- Blocks are not scaled according to physical size!
- Bus widths are labelled as in#,out# where in is into CCX or L2

FIGURE 1-1 OpenSPARC T1 Processor Block Diagram

1.3 OpenSPARC T1 Components

This section provides further details about the OpenSPARC T1 components.

1.3.1 SPARC Core

Each SPARC core has hardware support for four threads. This support consists of a full register file (with eight register windows) per thread, with most of the address space identifiers (ASI), ancillary state registers (ASR), and privileged registers replicated per thread. The four threads share the instruction, the data caches, and the TLBs. Each instruction cache is 16 Kbytes with a 32-byte line size. The data caches are write through, 8 Kbytes, and have a 16-byte line size. The TLBs include an autodemap feature which enables the multiple threads to update the TLB without locking.

Each SPARC core has single issue, six stage pipeline. These six stages are:

1. Fetch
2. Thread Selection
3. Decode
4. Execute
5. Memory
6. Write Back

[FIGURE 1-2](#) shows the SPARC core pipeline used in the OpenSPARC T1 Processor.

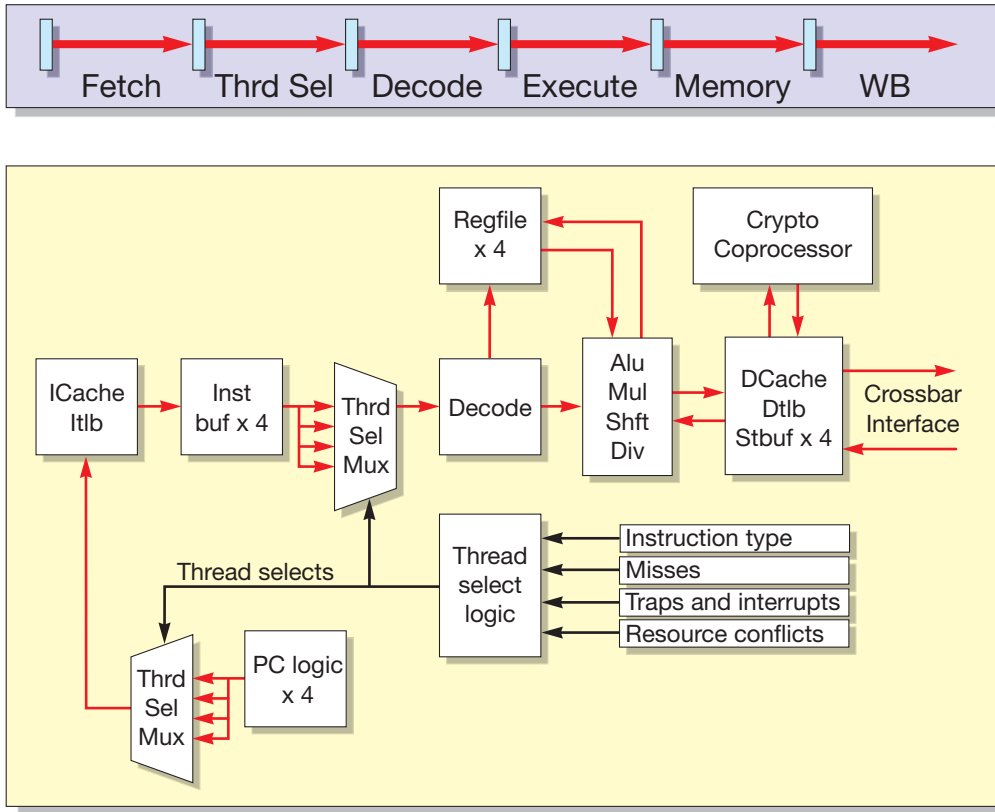

FIGURE 1-2 SPARC Core Pipeline

Each SPARC core has the following units:

1. Instruction fetch unit (IFU) includes the following pipeline stages – fetch, thread selection, and decode. The IFU also includes an instruction cache complex.
2. Execution unit (EXU) includes the execute stage of the pipeline.
3. Load/store unit (LSU) includes memory and writeback stages, and a data cache complex.
4. Trap logic unit (TLU) includes trap logic and trap program counters.
5. Stream processing unit (SPU) is used for modular arithmetic functions for crypto.
6. Memory management unit (MMU).
7. Floating-point frontend unit (FFU) interfaces to the FPU.

1.3.1.1 Instruction Fetch Unit

The thread selection policy is as follows – a switch between the available threads every cycle giving priority to the least recently executed thread. The threads become unavailable due to the long latency operations like loads, branch, MUL, and DIV, as well as to the pipeline stalls like cache misses, traps, and resource conflicts. The loads are speculated as cache hits, and the thread is switched-in with lower priority.

Instruction cache complex has a 16-Kbyte data, 4-way, 32-byte line size with a single ported instruction tag. It also has dual ported (1R/1W) valid bit array to hold cache line state of valid/invalid. Invalidates access the V-bit array, not the instruction tag. A pseudo-random replacement algorithm is used to replace the cache line.

There is a fully associative instruction TLB with 64 entries. The buffer supports the following page sizes: 8 Kbytes, 64 Kbytes, 4 Mbytes, and 256 Mbytes. The TLB uses a pseudo least recently used (LRU) algorithm for replacement. Multiple hits in the TLB are prevented by doing an autodemap on a fill.

Two instructions are fetched each cycle, though only one instruction is issued per clock, which reduces the instruction cache activity and allows for an opportunistic line fill. There is only one outstanding miss per thread, and only four per core. Duplicate misses do not issue requests to the L2-cache.

The integer register file (IRF) of the SPARC core has 5 Kbytes with 3 read/2 write/1 transport ports. There are 640 64-bit registers with error correction code (ECC). Only 32 registers from the current window are visible to the thread. Window changing in background occurs under the thread switch. Other threads continue to access the IRF (the IRF provides a single-cycle read/write access).

1.3.1.2 Execution Unit

The execution unit (EXU) has a single arithmetic logic unit (ALU) and shifter. The ALU is reused for branch address and virtual address calculation. The integer multiplier has a 5 clock latency, and a throughput of half-per-cycle for area saving. One integer multiplication is allowed outstanding per core. The integer multiplier is shared between the core pipe (EXU) and the modular arithmetic (SPU) unit on a round-robin basis. There is a simple non-restoring divider, which allows for one divide outstanding per SPARC core. Thread issuing a MUL/DIV will be rolled back and switched out if another thread is occupying the MUL/DIV units.

1.3.1.3 Load/Store Unit

The data cache complex has an 8-Kbyte data, 4-way, 16-byte line size. It also has single ported data tag. There is a dual ported (1R/1W) valid bit array to hold cache line state of valid or invalid. Invalidates access the V-bit array but not the data tag. A

pseudo-random replacement algorithm is used to replace the data cache line. The loads are allocating, and the stores are non-allocating. The data TLB operates similarly to the instruction TLB.

The load/store unit (LSU) has an 8 entry store buffer per thread, which is unified into a single 32 entry array, with RAW bypassing. Only a single load per thread outstanding is allowed. Duplicate requests for the same line are not sent to the L2-cache. The LSU has interface logic to interface to the CPU-cache crossbar (CCX). This interface performs the following operations:

- Prioritizes the requests to the crossbar for floating-point operation (Fpops), streaming operations, I\$ and D\$ misses, stores and interrupts, and so on.
- Request priority: imiss>ldmiss>stores,{fpu,stream,interrupt}.
- Assembles packets for the processor-cache crossbar (PCX).

The LSU handles returns from the CPX crossbar and maintains the order for cache updates and invalidates.

1.3.1.4 Floating-Point Frontend Unit

The floating-point frontend unit (FFU) decodes floating-point instructions and it also includes the floating-point register file (FRF). Some of the floating-point instructions like move, absolute value, and negate are implemented in the FFU, while the others are implemented in the FPU. The following steps are taken when the FFU detects a floating-point operation (Fpop):

- The thread switches out.
- The Fpop is further decoded and the FRF is read.
- Fpops with operands are packetized and shipped over the crossbar to the FPU.
- The computation is done in the FPU and the results are returned by way of the crossbar.
- Writeback completed to the FRF and the thread restarts.

1.3.1.5 Trap Logic Unit

The trap logic unit (TLU) has support for six trap levels. Traps cause pipeline flush and thread switch until trap program counter (PC) becomes available. The TLU also has support for up to 64 pending interrupts per thread.

1.3.1.6 Stream Processing Unit

The stream processing unit (SPU) includes a modular arithmetic unit (MAU) for crypto (one per core), and it supports asymmetric crypto (public key RSA) for up to a 2048-byte size key. It shares an integer multiplier for modular arithmetic operations. MAU can be used by one thread at a time. The MAU operation is set up by the store to control register, and the thread returns to normal processing. The MAU unit initiates streaming load/store operations to the L2-cache through the crossbar, and compute operations to the multiplier. Completion of the MAU can be checked by polling or issuing an interrupt.

1.3.2 CPU-Cache Crossbar

The eight SPARC cores, the four L2-cache banks, the I/O Bridge, and the FPU all interface with the crossbar. [FIGURE 1-3](#) displays the crossbar block diagram. The CPU-cache crossbar (CCX) features include:

- Each requester queues up to two packets per destination.
- Three stage pipeline – request, arbitrate, and transmit.
- Centralized arbitration with oldest requester getting priority.
- Core-to-cache bus optimized for address plus doubleword store.
- Cache-to-core bus optimized for 16-byte line fill. 32-byte I\$ line fill delivered in two back-to-back clocks.

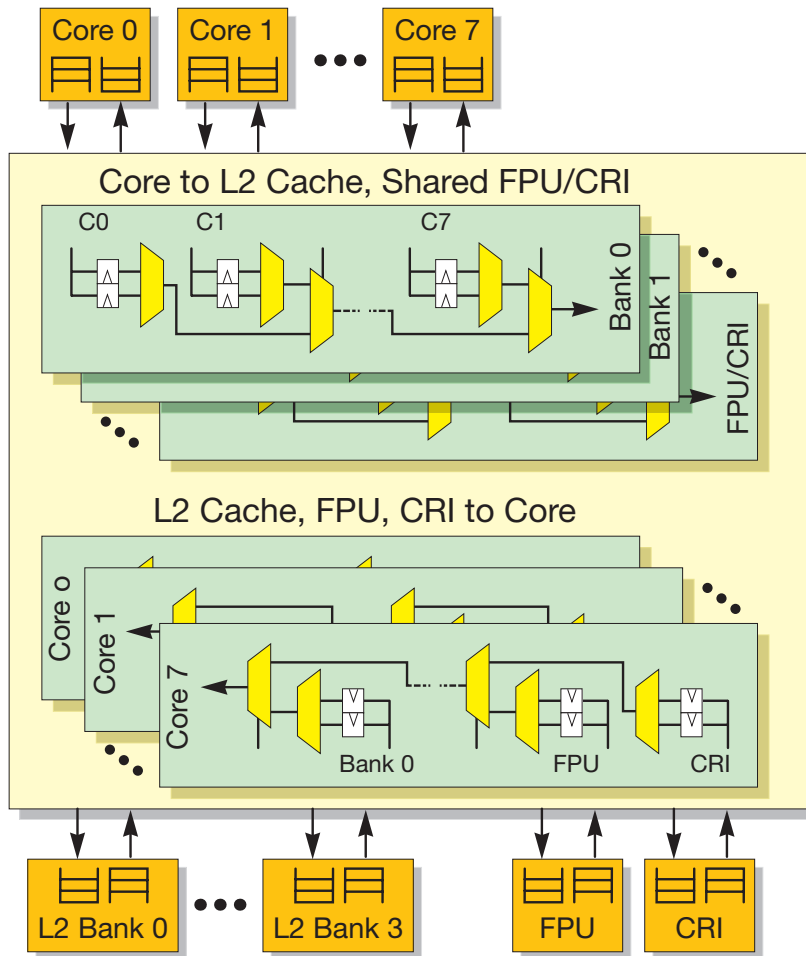

FIGURE 1-3 CCX Block Diagram

1.3.3 Floating-Point Unit

A single floating-point unit (FPU) is shared by all eight SPARC cores. The shared floating-point unit is sufficient for most commercial applications in which typically less than one percent of the instructions are floating-point operations.

1.3.4 L2-Cache

The L2-cache is banked four ways, with the bank selection based on the physical address bits 7:6. The cache is 3-Mbyte, 12-way set-associative with pseudo-least recently used (LRU) replacement (the replacement is based on a used bit scheme). The line size is 64 bytes. Unloaded access time is 23 cycles for an L1 data cache miss and 22 cycles for an L1 instruction cache miss.

L2-cache has a 64-byte line size, with 64 bytes interleaved between banks. Pipeline latency in the L2-cache is 8 clocks for a load, 9 clocks for an I-miss, with the critical chunk returned first. 16 outstanding misses per bank are supported for a 64 total misses. Coherence is maintained by shadowing the L1 tags in an L2-cache directory structure (the L2-cache is a point of global visibility). DMA from the I/O is serialized with respect to the traffic from the cores in the L2-cache.

The L2-cache directory shadows the L1 tags. The L1 set index and the L2-cache bank interleaving is such that one fourth of the L1 entries come from an L2-cache bank. On an L1 miss, the L1 replacement way and set index identifies the physical location of the tag which will be updated by the miss address. On a store, the directory will be cammed. The directory entries are collated by set, so only 64 entries need to be cammed. This scheme is quite power efficient. Invalidates are a pointer to the physical location in the L1-cache, eliminating the need for a tag lookup in the L1-cache.

Coherency and ordering in the L2-cache are described as:

- Loads update directory and fill the L1-cache on return
- Stores are non-allocating in the L1-cache
 - There are two flavors of stores: total store order (TSO) and read memory order (RMO).

Only one outstanding TSO store to the L2-cache per thread is permitted in order to preserve the store ordering. There is no such limitation on RMO stores.
 - No tag check is done at a store buffer insert
 - Stores check directory and determines an L1-cache hit
 - Directory sends store acknowledgements or invalidates to the SPARC core
 - Store updates happens to D\$ on a store acknowledge
- Crossbar orders the responses across cache banks.

1.3.5 DRAM Controller

The OpenSPARC T1 processor DRAM controller is banked four ways, with each L2 bank interacting with exactly one DRAM controller bank (a two-bank option is available for cost-constrained minimal memory configurations). The DRAM controller is interleaved based on physical address bits 7:6, so each DRAM controller bank must have identical dual in-line memory modules (DIMM) installed and enabled.

The OpenSPARC T1 processor uses DDR2 DIMMs and can support one or two ranks of stacked or unstacked DIMMs. Each DRAM bank/port is two-DIMMs wide (128-bit + 16-bit ECC). All installed DIMMs must be identical, and the same number of DIMMs (that is, ranks) must be installed on each DRAM controller port. The DRAM controller frequency is an exact ratio of the core frequency, where the core frequency must be at least three times the DRAM controller frequency. The double data rate (DDR) data buses transfer data at twice the frequency of the DRAM controller frequency.

The OpenSPARC T1 processor can support memory sizes of up to 128 Gbytes with a 25 Gbytes/sec peak bandwidth limit. Memory access is scheduled across 8 reads plus 8 writes, and the processor can be programmed into a two-channel mode for a reduced configuration. Each DRAM channel has 128 bits of data and 16 bytes of ECC interface, with chipkill support, nibble error correction, and byte error detection.

1.3.6 I/O Bridge

The I/O bridge (IOB) performs an address decode on I/O-addressable transactions and directs them to the appropriate internal block or to the appropriate external interface (J-Bus or the serial system interface). Additionally, the IOB maintains the register status for external interrupts.

1.3.7 J-Bus Interface

The J-Bus interface (JBI) is the interconnect between the OpenSPARC T1 processor and the I/O subsystem. The J-Bus is a 200 MHz, 128-bit wide, multiplexed address or data bus, used predominantly for direct memory access (DMA) traffic, plus the programmable input/output (PIO) traffic used to control it.

The J-Bus interface is the functional block that interfaces to the J-Bus, receiving and responding to DMA requests, routing them to the appropriate L2 banks, and also issuing PIO transactions on behalf of the processor threads and forwarding responses back.

1.3.8 Serial System Interface

The OpenSPARC T1 processor has a 50 Mbyte/sec serial system interface (SSI) that connects to an external application-specific integrated circuit (ASIC), which in turn interfaces to the boot read-only memory (ROM). In addition, the SSI supports PIO accesses across the SSI, thus supporting optional control status registers (CSR) or other interfaces within the ASIC.

1.3.9 Electronic Fuse

The electronic fuse (e-Fuse) block contains configuration information that is electronically burned-in as part of manufacturing, including part serial number and core available information.

SPARC Core

An OpenSPARC T1 processor contains eight SPARC cores, and each SPARC core has several function units. These SPARC core units are described in the following sections:

- [Section 2.1, “SPARC Core Overview and Terminology” on page 2-2](#)
- [Section 2.2, “SPARC Core I/O Signal List” on page 2-5](#)
- [Section 2.3, “Instruction Fetch Unit” on page 2-6](#)
- [Section 2.4, “Load Store Unit” on page 2-21](#)
- [Section 2.5, “Execution Unit” on page 2-33](#)
- [Section 2.6, “Floating-Point Frontend Unit” on page 2-35](#)
- [Section 2.7, “Multiplier Unit” on page 2-37](#)
- [Section 2.8, “Stream Processing Unit” on page 2-38](#)
- [Section 2.9, “Memory Management Unit” on page 2-43](#)
- [Section 2.10, “Trap Logic Unit” on page 2-50](#)

2.1 SPARC Core Overview and Terminology

FIGURE 2-1 presents a high-level block diagram of a SPARC core, and FIGURE 2-2 shows the general physical location of these units on an example core.

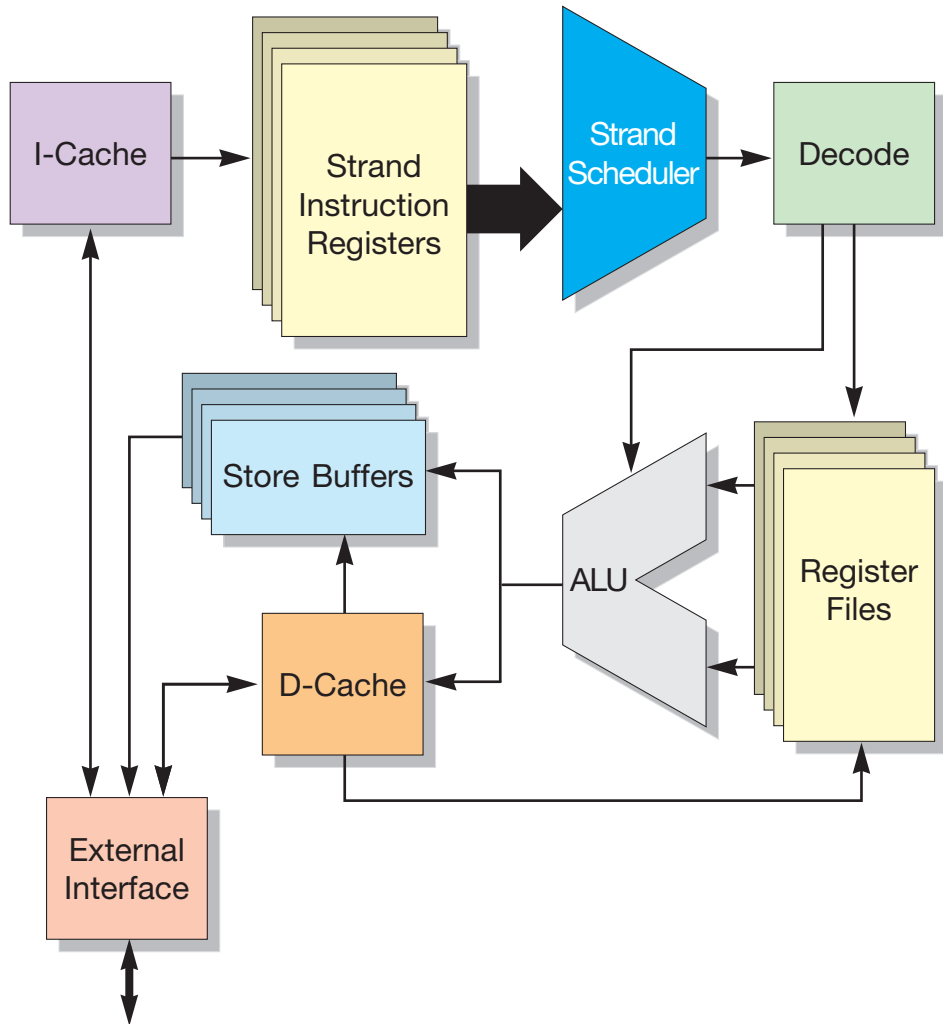

FIGURE 2-1 SPARC Core Block Diagram

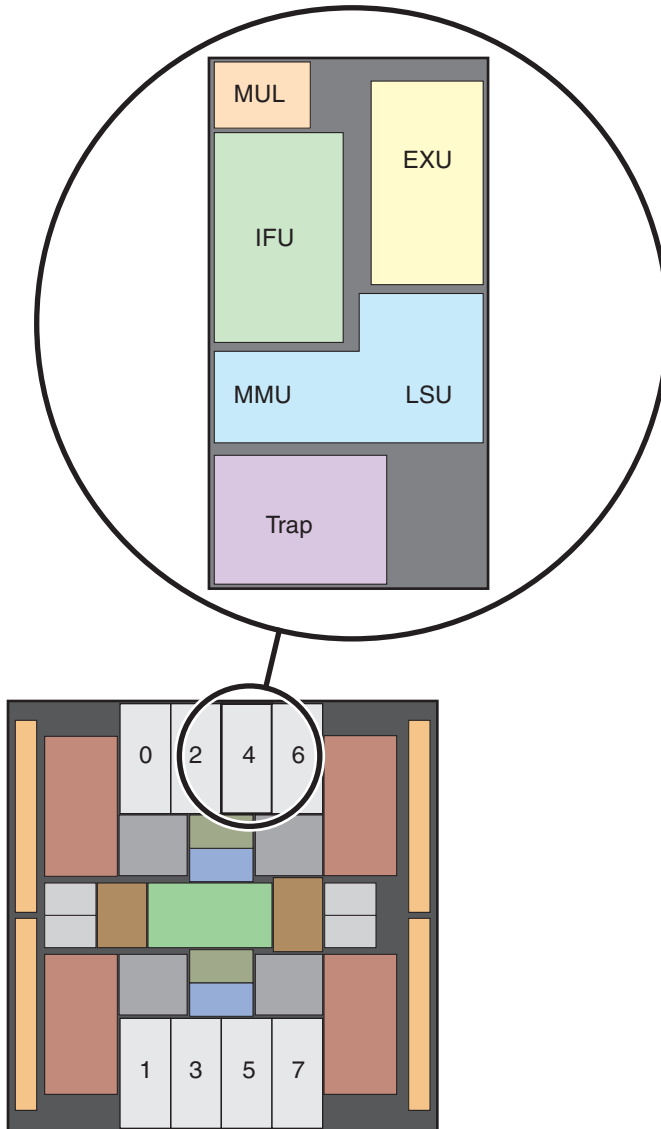

FIGURE 2-2 Physical Location of Functional Units on an OpenSPARC T1 SPARC Core

TABLE 2-1 defines acronyms and terms that are used throughout this chapter.

TABLE 2-1 SPARC Core Terminology

Term	Description
Thread	<p>A thread is a hardware strand (<i>thread</i> and <i>strand</i> will be used interchangeably in this chapter). Each thread, or strand, enjoys a unique set of resources in support of its execution while multiple threads, or strands, within the same SPARC core will share a set of common resources in support of their execution.</p> <p>The per-thread resources include registers, a portion of I-fetch data-path, store buffer, and miss buffer. The shared resources include the pipeline registers and data-path, caches, translation lookaside buffers (TLB), and execution unit of the SPARC Core pipeline.</p>
ST	Single threaded.
MT	Multi-threaded.
Hypervisor (HV)	The hypervisor is the layer of system software that interfaces with the hardware.
Supervisor (SV)	The supervisor is the layer of system software such as operation system (OS) that executes with privilege.
Long latency instruction (LLI)	LLI represents an instruction that would take more than one SPARC core clock cycle to make its results visible to the next instruction.

FIGURE 2-3 shows the view from virtualization, which illustrates the relative privileges of the various software layers.

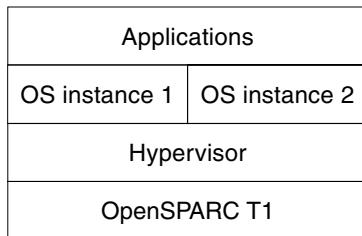

FIGURE 2-3 Virtualization of Software Layers

2.2 SPARC Core I/O Signal List

TABLE 2-2 lists and describes the SPARC Core I/O signals.

TABLE 2-2 SPARC Core I/O Signal List

Signal Name	I/O	Source/ Destination	Description
pcx_spc_grant_px[4:0]	In	CCX:PCX	PCX to processor grant info
cpx_spc_data_rdy_cx2	In	CCX:CPX	CPX data in-flight to SPARC
cpx_spc_data_cx2[144:0]	In	CCX:CPX	CPX to SPARC data packet
const_cpuid[3:0]	In	Hard wired	CPU ID
const_maskid[7:0]	In	CTU	Mask ID
ctu_tck	In	CTU	To IFU of sparc_ifu.v
ctu_sscan_se	In	CTU	To IFU of sparc_ifu.v
ctu_sscan_snap	In	CTU	To IFU of sparc_ifu.v
ctu_sscan_tid[3:0]	In	CTU	To IFU of sparc_ifu.v
ctu_tst_mbist_enable	In	CTU	To test_stub of test_stub_bist.v
efc_spc_fuse_clk1	In	EFC	
efc_spc_fuse_clk2	In	EFC	
efc_spc_ifuse_ashift	In	EFC	
efc_spc_ifuse_dshift	In	EFC	
efc_spc_ifuse_data	In	EFC	
efc_spc_dfuse_ashift	In	EFC	
efc_spc_dfuse_dshift	In	EFC	
efc_spc_dfuse_data	In	EFC	
ctu_tst_macrotest	In	CTU	To test_stub of test_stub_bist.v
ctu_tst_scan_disable	In	CTU	To test_stub of test_stub_bist.v
ctu_tst_short_chain	In	CTU	To test_stub of test_stub_bist.v
global_shift_enable	In	CTU	To test_stub of test_stub_two_bist.v
ctu_tst_scanmode	In	CTU	To test_stub of test_stub_two_bist.v
spc_scanin0	In	DFT	Scan in
spc_scanin1	In	DFT	Scan in

TABLE 2-2 SPARC Core I/O Signal List (*Continued*)

Signal Name	I/O	Source/ Destination	Description
cluster_cken	In	CTU	To spc_hdr of cluster_header.v
gclk	In	CTU	To spc_hdr of cluster_header.v
cmp_grst_l	In	CTU	Synchronous reset
cmp_arst_l	In	CTU	Asynchronous reset
ctu_tst_pre_grst_l	In	CTU	To test_stub of test_stub_bist.v
adbginit_l	In	CTU	Asynchronous reset
gdbginit_l	In	CTU	Synchronous reset
spc_pcx_req_pq[4:0]	Out	CCX:PCX	processor to pcx request
spc_pcx_atom_pq	Out	CCX:PCX	processor to pcx atomic request
spc_pcx_data_pa[123:0]	Out	CCX:PCX	processor to pcx packet
spc_sscan_so	Out	DFT	Shadow scan out
spc_scanout0	Out	DFT	Scan out
spc_scanout1	Out	DFT	Scan out
tst_ctu_mbist_done	Out	CTU	MBIST done
tst_ctu_mbist_fail	Out	CTU	MBIST fail
spc_efc_ifuse_data	Out	EFC	From IFU of sparc_ifu.v
spc_efc_dfuse_data	Out	EFC	From IFU of sparc_ifu.v

2.3 Instruction Fetch Unit

The instruction fetch unit (IFU) is responsible for maintaining the program counters (PC) of different threads and fetching the corresponding instructions. The IFU also manages the level 1 I-cache (L1I) and the instruction translation lookaside buffer (ITLB), as well as managing and scheduling the four threads in a SPARC core. The SPARC core pipeline resides in the IFU, which controls instruction issue and instruction flow in the pipeline. The IFU decodes the instructions flowing through the pipeline, schedules interrupts, and it implements the idle/resume states of the pipeline. The IFU also logs the errors and manages the error registers.

2.3.1 SPARC Core Pipeline

There are six stages in a SPARC core pipeline:

- Fetch – F-stage
- Thread selection – S-stage
- Decode – D-stage
- Execute – E-stage
- Memory – M-stage
- Writeback – W-stage

The I-cache access and the ITLB access take place in fetch stage. A selected thread (hardware strand) will be picked in the thread selection stage. The instruction decoding and register file access occur in the decode stage. The branch evaluation takes place in the execution stage. The access to memory and the actual writeback will be done in the memory and writeback stages. [FIGURE 2-4](#) illustrates the SPARC core pipeline and support structures.

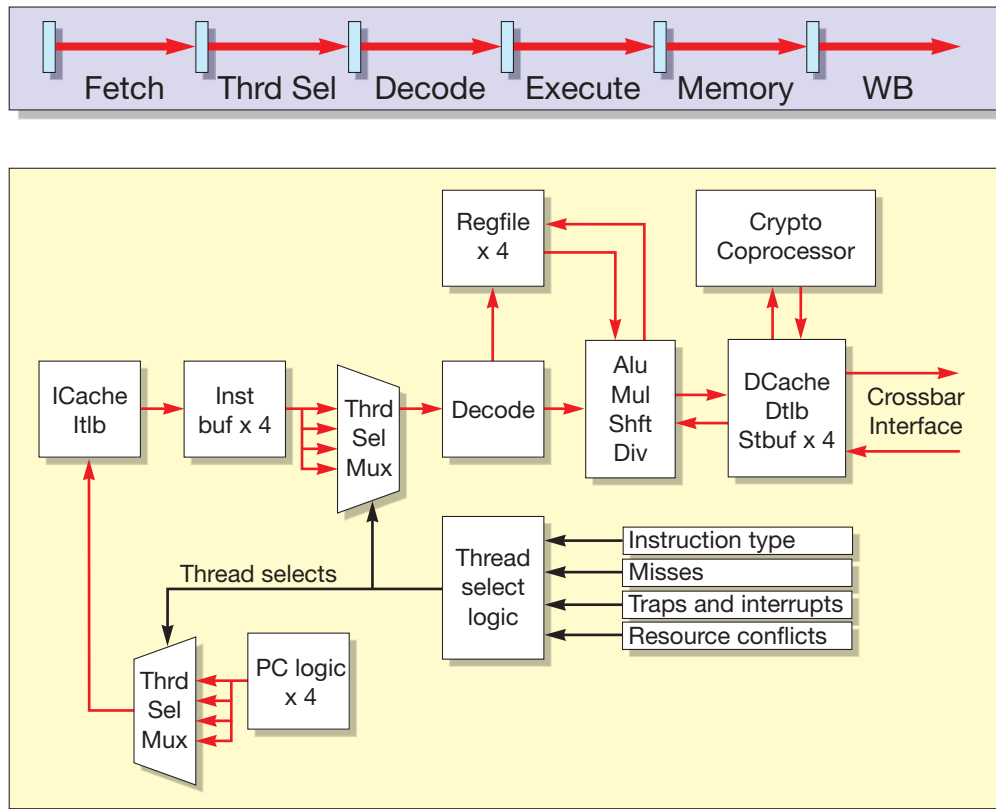

FIGURE 2-4 SPARC Core Pipeline and Support Structures

The instruction fill queue (IFQ) feeds into the I-cache. The missed instruction list (MIL) stores the addresses that missed the I-cache and the ITLB, and the MIL feeds into the load store unit (LSU) for further processing. The instruction buffer is two levels deep, and it includes the thread instruction (TIR) and next instruction (NIR) unit. Thread selection and scheduler (S-stage) resolves the arbitration among the TIR, NIR, branch-PC, and trap-PC to pick one thread send it to the decode stage (D-stage). FIGURE 2-5 shows the support structure for this portion of the thread pipeline.

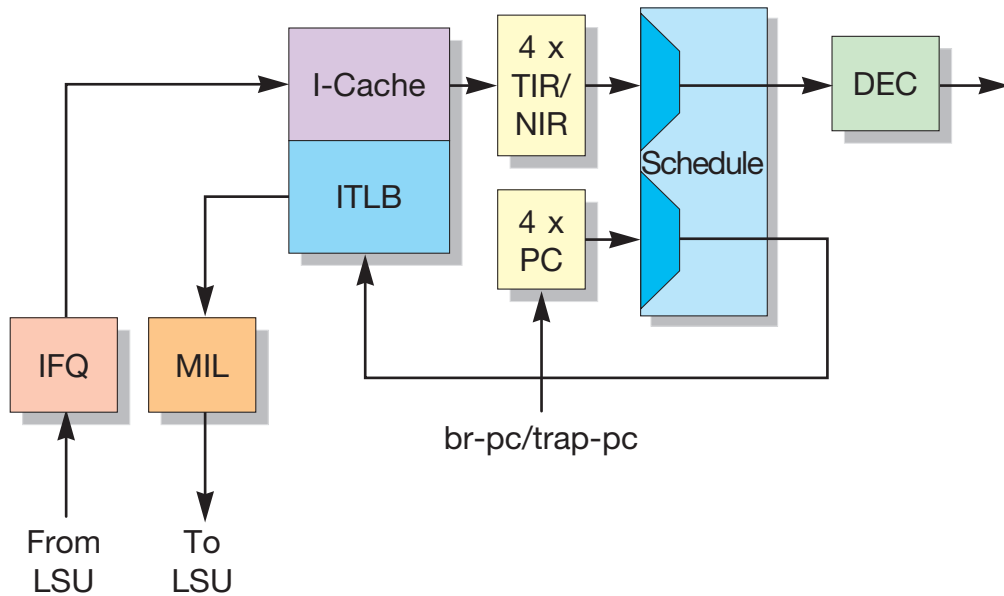

FIGURE 2-5 Frontend of the SPARC Core Pipeline

2.3.2 Instruction Fetch

The instruction fetch unit (IFU) maintains the program counters (PC) and the next-program counters (NPC) of all live instructions executed on the OpenSPARC T1 processor. For every SPARC core clock cycle, two instructions are fetched for every instruction issued. This two fetches per one issue relationship is intended to reduce the I-cache access in order to allow the opportunistic I-cache line fill. Each thread is allowed to have one outstanding I-cache miss, and the SPARC core allows a total of four I-cache misses. Duplicated I-cache misses do not induce the redundant fill request to the level 2 cache (L2-cache).

2.3.3 Instruction Registers and Program Counter Registers

In the instruction buffer, there are two instruction registers per thread – the thread instruction register (TIR) and the next instruction register (NIR). The TIR contains the current thread instruction in the thread selection stage (S-stage), and the NIR contains the next instruction. An I-cache miss fill bypasses the I-cache and writes directly to the TIR, but it never writes to the NIR.

The thread scheduler selects a valid instruction from the TIR. After selecting the instruction, the valid instruction will be moved from the NIR to the TIR. If no valid instruction exists in the TIR, a no operation (NOP) instruction will be inserted.

There is one program counter (PC) register per thread. The next-program counter (NPC) could come from one of these sources:

1. Branch
2. TrapPC
3. Trap NPC
4. Rollback (a thread rolled back due to a load miss)
5. PC + 4

The IFU tracks the PC and NPC through W-stage. The last retired PC will be saved in the trap logic unit (TLU), and, if a trap occurs, it will also be saved in the trap stack.

2.3.4 Level 1 Instruction Cache

The instruction cache is commonly referred to as the level 1 instruction cache (L1I). The L1I is physically indexed and tagged and is 4-way set associative with 16 Kbytes of data. The cache-line size is 32 bytes. The L1I data array has a single port, and the I-cache fill size is 16 bytes per access. The characteristics of cached data include – 32-bit instructions, 1-bit parity, and 1-bit predecode. The tag array also has a single port.

There is a separate array for valid bit (V-bit). This V-bit array holds the cache line state of either valid or invalid, and the array has one read port and one write port (1R1W). The cache line invalidation only accesses the V-bit array, and the cache line replacement policy is pseudo-random.

The read access to the I-cache has a higher priority over the write access. The ASI read and write accesses to the I-cache are set to lower priorities. The completion of the ASI accesses are opportunistic, and there is fairness mechanism built in to prevent the starvation of service to ASI accesses.

The maximum wait period for a write access to the I-cache is 25 SPARC core clock cycles. A wait longer than 25 clock cycles will stall the SPARC core pipeline in order to allow the I-cache write access completion.

2.3.5 I-Cache Fill Path

I-cache fill packets come from the level 2 cache to processor interface (CPX) by way of the load store unit (LSU). Parity and predecode bits will be calculated before the I-cache fills up. CPX packets include invalidations (invalidation packets are non-blocking), test access point (TAP) reads and writes, and error notifications. The valid bit array in the I-cache has a dedicated port for servicing the invalidation packets.

FIGURE 2-6 illustrates the I-cache fill path.

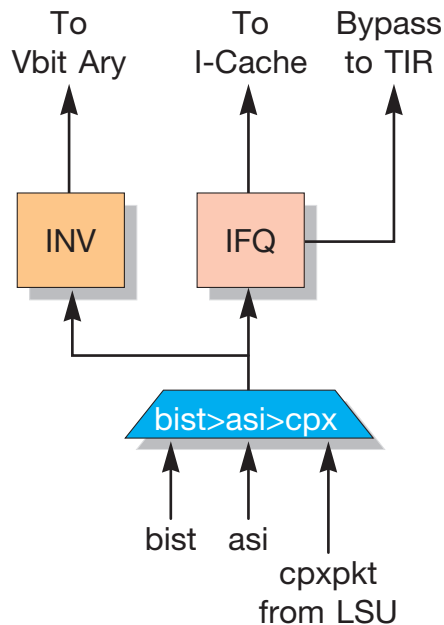

FIGURE 2-6 I-Cache Fill Path

The I-cache line size is 32 bytes, and a normal I-cache fill takes two CPX packets of 16 bytes each. The instruction fill queue (IFQ) has a depth of two. An I-cache line will be invalidated when the first CPX packet is delivered and filled in the I-cache.

That cache line will be marked as valid when the second CPX packet is delivered and filled. I-cache control guarantees the atomicity of the I-cache line fill action between the two halves of the cache line being filled.

An instruction fetch from the boot PROM, by way of the system serial interface (SSI), is a very slow transaction. The boot prom is a part of the I/O address space. All instruction fetches from the I/O space are non-cacheable. The boot PROM fetches only one 4-byte instruction at a time. This 4-byte instruction is replicated four times during the formation of the CPX packet. Only one CPX packet of non-cacheable instructions will be forwarded to the IFQ. The non-cacheable instructions fetched from the boot PROM will not be filled in the I-cache. They will be sent to (or, bypassed to) the thread instruction register (TIR) directly.

2.3.6 Alternate Space Identifier Accesses, I-Cache Line Invalidations, and Built-In Self-Test Accesses to the I-Cache

Alternate space identifiers (ASI) accesses to the I-cache, and the built-in self-test (BIST) accesses to the I-cache, go through the IFQ data-path to the I-cache. All ASI accesses and BIST accesses will cause the SPARC core pipeline to stall, so these accesses are serviced almost immediately.

The load store unit (LSU) initiates all ASI accesses. The LSU serializes all ASI accesses so that the second access will not be launched until the first access has been acknowledged. ASI accesses tend to be slow, and data for an ASI read will be sent back later.

A BIST operation requires atomicity, and it assumes and accommodates no interruptions until it completes.

Level 2 cache invalidations will always undergo a CPU-ID check in order to ensure that this invalidation packet is indeed meant for the specified SPARC core. In the following cases, an invalidation could be addressing anyone:

- A single I-cache line invalidation due to store acknowledgements, or due to a load exclusivity requiring that the invalidation of the other level 1 I-caches resulted from the self-modifying code.
- Invalidating two I-cache lines because of a cache-line eviction in the level 2 cache (L2-cache).
- Invalidating all ways in a given set due to error conditions, such as encountering a tag ECC error in a level 2 cache line.

2.3.7 I-Cache Miss Path

A missed instruction list (MIL) is responsible for sending the I-cache miss request to the level 2 cache (L2-cache) in order to get an I-cache fill. The MIL has one entry per thread, which supports a total of four outstanding I-cache misses for all four threads in the same SPARC core at the same time. Each entry in the MIL contains the physical address (PA) of an instruction that missed the I-cache, the replacement way information, the MIL state information, the cacheability, the error information, and so on. The PA tracks the I-fetch progress from the indication of an I-cache miss until the I-cache has been filled. The dispatch of I-cache miss requests from different threads follow a fairness mechanism based on a round-robin algorithm.

FIGURE 2-7 illustrates the I-cache miss path.

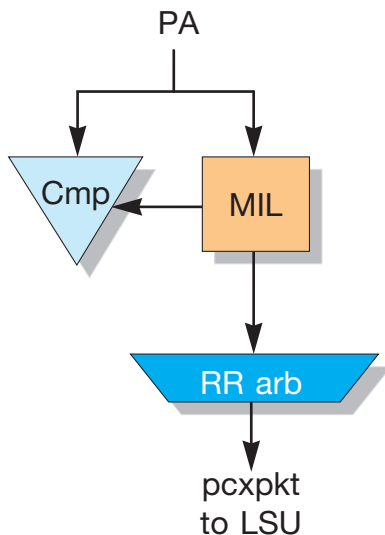

FIGURE 2-7 I-Cache Miss Path

The MIL keeps track of the physical address (PA) of an instruction that missed the I-cache. A second PA that matches the PA of an already pending I-cache miss will cause the second request to be put on hold and marked as a *child* of the pending I-cache miss request. The child request will be serviced when the pending I-cache miss receives its response. The MIL uses a linked list to track and service the duplicated I-cache miss request. The depth for such a linked list is four.

The MIL cycles through the following states:

1. Make request.
2. Wait for an I-cache fill.
3. Fill the first 16 bytes of data. The MIL sends a speculative completion notification to the thread scheduler at the completion of filling the first 16 bytes.
4. Fill the second 16 bytes of data. The MIL sends a completion notification to the thread scheduler at the completion of filling the second 16 bytes.
5. Done.

An I-cache miss request could be canceled because of, for example, a trap. The MIL still goes through the motions of filling a cache line but it does not bypass it to the thread instruction register (TIR). A pending child request must be serviced even if the original parent I-cache miss request was cancelled.

When a child I-cache miss request crosses with a parent I-cache miss request, the child request might not be serviced before the I-cache fill for the parent request occurs. The child instruction fetch shall be retired (rolled back) to the F-stage to allow it to access the I-cache. This kind of case is referred to as miss-fill crossover.

2.3.8 Windowed Integer Register File

The integer register file (IRF) contains 5 Kbytes of storage, and has three read ports, 2 write ports, and one transfer port (3R/2W/1T). The IRF houses 640 64-bit registers that are protected by error correcting code (ECC). All read or write accesses can be completed in one SPARC core clock cycle.

[FIGURE 2-8](#) illustrates the structure of an integer architectural register file (IARF) and an integer working register file (IWRF).

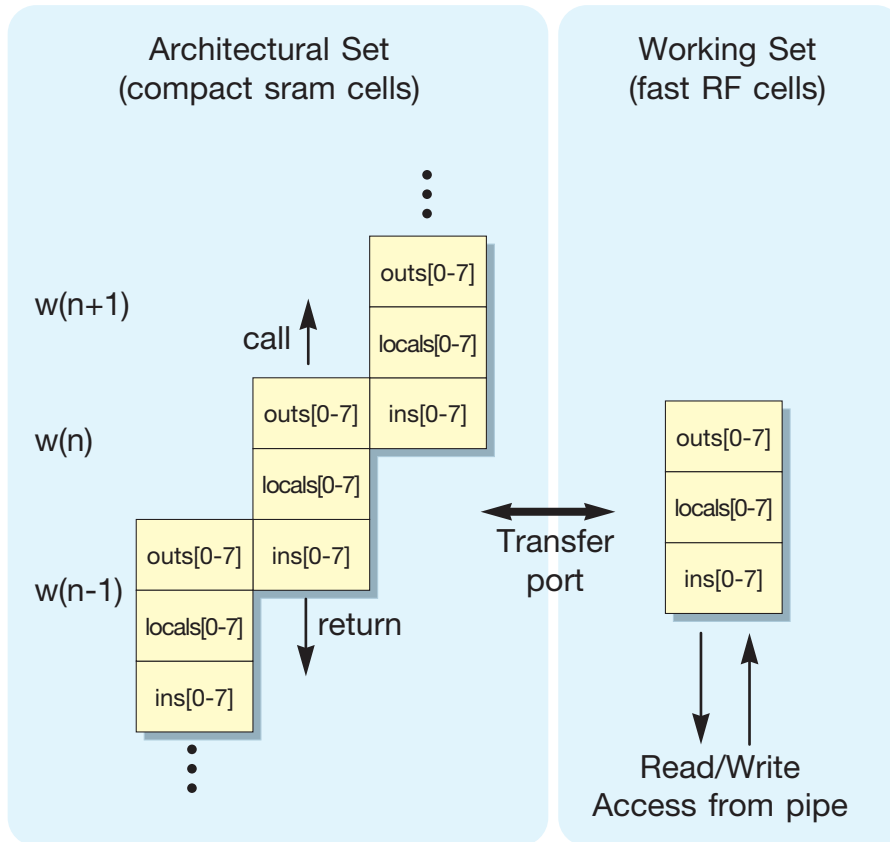

FIGURE 2-8 IARF and IWRF File Structure

Each thread requires 128 registers for the eight windows (with 16 registers per window), and four sets of global registers with eight global registers per set. There are 160 registers per thread, and there are four threads per SPARC core. There are a total of 640 registers per SPARC core.

Only 32 registers from the current window are visible to the thread. A window change occurs in the background under thread switching while the other threads continue to access integer register file.

Please refer to *OpenSPARC T1 Processor Megacell Specification* for additional details on the IRF.

2.3.9 Instruction Table Lookaside Buffer

The instruction table lookaside buffer (ITLB) is responsible for address translation and tag comparison. The ITLB is always turned-on for non-hypervisor mode operations, and the ITLB is always turned-off for hypervisor mode operations.

The ITLB contains 64 entries. The replacement policy is a pseudo least recently used (pseudo-LRU) policy, which is the same policy as that for the I-cache.

The ITLB supports page sizes of 8 Kbytes, 64 Kbytes, 4 Mbytes, and 256 Mbytes. Multiple hits in the ITLB are prevented by the autodemap feature in an ITLB fill.

2.3.10 Thread Selection Policy

Thread switching takes place during every SPARC core clock cycle. At the time of a thread selection, the priority is given to the least recently executed yet available thread. Load instructions will be speculated as cache hits and the thread executing a load instruction will be deemed as available and allowed to be switched-in with a low priority.

A thread could become unavailable due to one of these reasons:

1. The thread is executing one of the long latency instructions, such as load, branch, multiplication, division, and so on.
2. The SPARC core pipeline has been stalled due to one of the long latency operations, such as encountering a cache miss, taking a trap, or experiencing a resource conflict.

2.3.11 Thread States

A thread cycles through these three different states – idle, active, and halt. [FIGURE 2-9](#) illustrates the basic transition of non-active states.

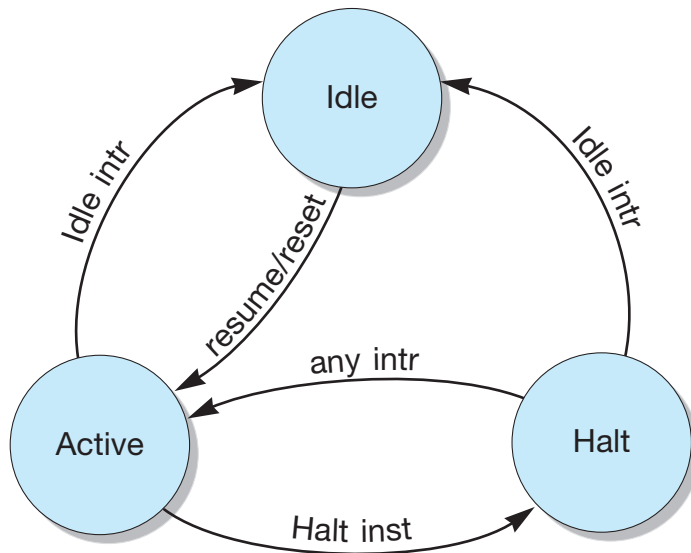

FIGURE 2-9 Basic Transition of Non-Active States

A thread is in an idle state at power-on. An active thread will only be transitioned to an idle state after a wait mask for an I-cache fill has been cleared.

A thread in the idle state should not receive the *resume* command without a previous reset. When a thread is violated, the integrity of the hardware behavior cannot be guaranteed.

[FIGURE 2-10](#) illustrates the thread state transition of an active thread.

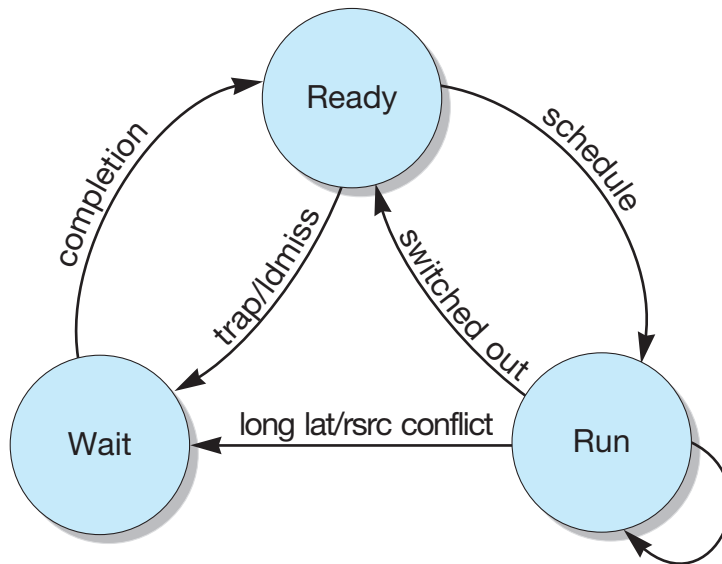

FIGURE 2-10 Thread State Transition of an Active Thread

An active thread could be placed in the wait state because of any of the following reasons:

1. Wait for an I-cache fill.
2. Wait due to store buffer full.
3. Wait due to long latency, or a resource conflict where all resource conflicts arise because of long latency.
4. Wait due to any combination of the preceding reasons.

The current wait state is tracked in the IFU wait masks.

[FIGURE 2-11](#) illustrates the state transition for a thread in speculative states.

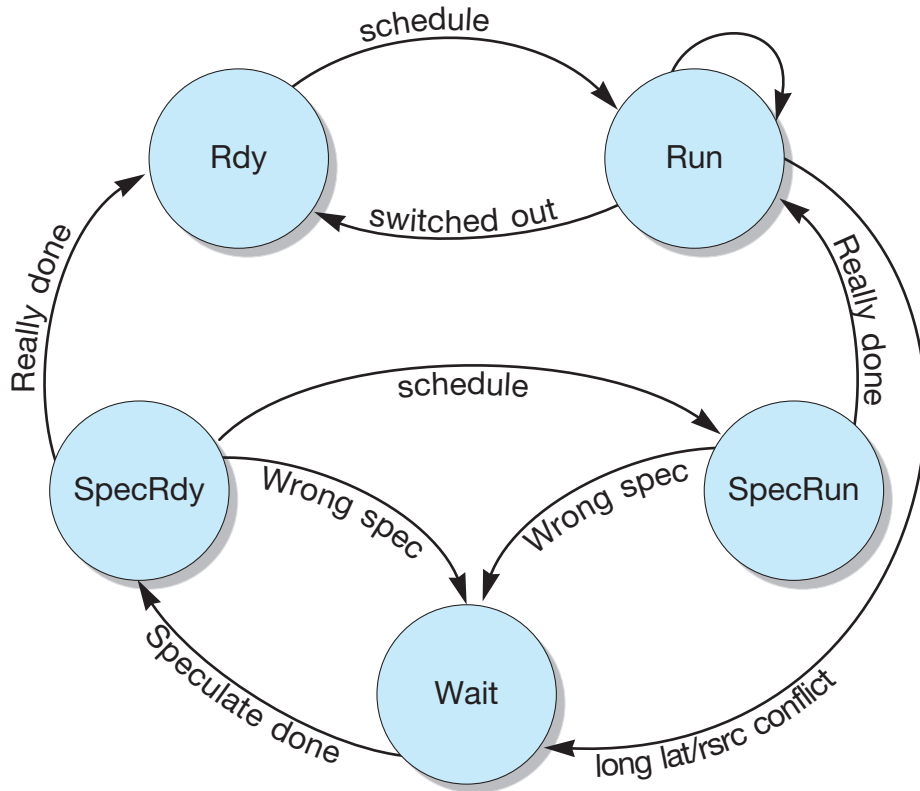

FIGURE 2-11 State Transition for a Thread in Speculative States

2.3.12 Thread Scheduling

A thread can be scheduled when it is in one of the following five states – idle (which happens infrequently, and generally results from a reset or resume interrupt), Rdy, SpecRdy, Run, and SpecRun. The thread priority in each state is different at the time for scheduling. The priority scheme can be characterized as follows:

Idle > Rdy > SpecRdy > (Run = SpecRun)

The fairness scheme for threads in the Run state or the SpecRun state is a round-robin algorithm with the least recently executed thread winning the selection.

Within Idle threads, the priority scheme is as follows:

T0 (thread 0) > T1 (thread 1) > T2 (thread 2) > T3 (thread 3)

2.3.13 Rollback Mechanism

The rollback mechanism provides a way of recovering from a scheduling error. The two reasons for performing a rollback include:

1. All of the stall conditions, or switch conditions, were not known at the time of the scheduling.
2. The scheduling was done speculatively on purpose.

For example, after issuing a load, the scheduler will speculate a level 1 D-cache hit performance reasons. If the speculation was incorrect (because of encountering a load miss), all of the instructions after the speculative load instruction must be rolled back. Otherwise, the performance gain would be a substantial.

Rolled back instructions must be restarted from the S-stage or F-stage of the SPARC core pipeline. [FIGURE 2-12](#) illustrates the pipeline graph for the rollback mechanism.

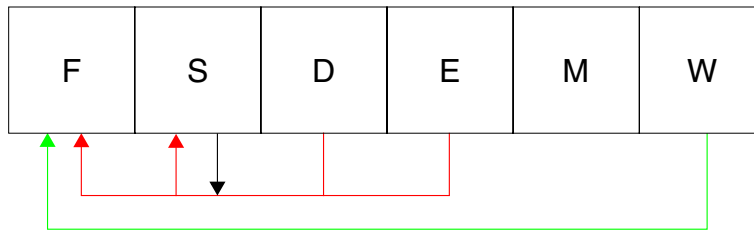

FIGURE 2-12 Rollback Mechanism Pipeline Graph

The three rollback cases include:

1. E to S and D to F
2. D to S and S to F
3. W to F

The possible conditions causing a rollback case 1 or a case 2 include:

- Instruction(s) following a load miss
- Resource conflict due to long latency
- Store buffer full
- I-cache instruction parity error
- I-fetch retry

The possible conditions causing rollback case 3 include:

- Encountering an ECC error during the instruction register file access.
- The floating-point store instruction encountering an ECC error during the floating-point register file access.
- Instruction(s) following a load hits the store buffer and the level 1 D-cache, where the data has not been bypassed from the store buffer to the level 1 D-cache.
- Encountering D-cache parity errors.
- Launching an idle or resume interrupt where the machine states must be restored.
- An interrupt has been scheduled but not yet taken.

2.3.14 Instruction Decode

The IFU decodes the SPARC V9 instructions, and the floating-point frontend unit (FFU) decodes the floating-point instructions. Unimplemented floating-point instructions will cause an `fp_exception_other` trap with a `FSR.ftt=3` (`unimplemented_FPop`). These operations will be emulated by the software.

The privilege is checked in D-stage of the SPARC core pipeline. Some instructions can only be executed with hypervisor privilege or with supervisor privilege.

The branch condition is also evaluated in the D-stage, and the decision for annulling a delay slot is made in this stage as well.

2.3.15 Instruction Fetch Unit Interrupt Handling

All interrupts are delivered to the instruction fetch unit (IFU). For each received interrupt, the IFU shall check the bit's `pstate.ie` (the interrupt enable bit in the processor state register) and `hpstate` (the hypervisor state) before scheduling the interrupt. All interrupts will be prioritized (refer to the *Programmer's Reference Manual* for these priority assignments). Once prioritized, the interrupts will be scheduled just like the instructions.

When executing in the hypervisor (HV) state, an interrupt with a supervisor (SV) privilege will not be serviced at all. An hypervisor state execution shall not be blocked by anything with supervisor privilege.

Nothing could block the scheduling of a reset, idle, or resume interrupt.

Some interrupts are asserted by a level while others are asserted by a pulse. The IFU remembers the form the interrupts were originated in order to preserve the integrity of the scheduling.

2.3.16 Error Checking and Logging

Parity protects the I-cache data and the tag arrays. The error correction action is to re-fetch the instruction from the level 2 cache.

The instruction translation lookaside buffer (ITLB) array is parity decoded without an error-correction mechanism, so all errors are fatal.

All on-core errors, and some of the off-core errors, are logged in the per-thread error registers. Refer to the *Programmer's Reference Manual* for details.

The instruction fetch unit (IFU) maintains the error injection and the error enabling registers, which are accessible by way of ASI operations.

Critical states (such as program counter (PC), thread state, missed instruction list (MIL), and so on) can be snapped and scanned out on-line. This process is referred to as a *shadow scan*.

2.4 Load Store Unit

The load store unit (LSU) processes memory referencing operation codes (opcodes) such as various types of loads, various types of stores, cas, swap, ldstub, flush, prefetch, and membar. The LSU interfaces with all of the SPARC core functional units, and acts as the gateway between the SPARC core units and the CCX. Through the CCX, data transfer paths can be established with the memory subsystem and the I/O subsystem (the data transfers are done with packets).

The threaded architecture of the LSU can process four loads, four stores, one fetch, one FP operation, one stream operation, one interrupt, and one forward packet. Therefore, thirteen sources supply data to the LSU.

The LSU implements the ordering for memory references, whether locally or not. The LSU also enforces the ordering for all the outbound and inbound packets.

2.4.1 LSU Pipeline

There are four stages in the LSU pipeline. [FIGURE 2-13](#) shows the different stages of the LSU pipeline.

E Cache TLB setup	M Cache/Tag TLB read	W stb lookup traps bypass	W2 pcx rcq gcn. and writeback
-----------------------------------	--------------------------------------	---	--

FIGURE 2-13 LSU Pipeline Graph

The cache access set-up and the translation lookaside buffer (TLB) access set-up are done during the pipeline's E-stage (execution). The cache/tag/TLB read operations are done in the M-stage (memory access). The W-stage (writeback) supports the look-up of the store buffer, the detection of traps, and the execution of the data bypass. The W2-stage (writeback-2) is for generating PCX requests and writebacks to the cache.

2.4.2 Data Flow

The LSU includes an 8-Kbyte D-cache, which is a part of the level 1 cache shared by four threads. There is one store buffer (STB) per thread. Stores are total store ordering (TSO) ordered, that is to say that no `membar #sync` is required after each store operation in order to maintain the program order among the stores. Non-TSO compliant stores include `- blk-store` and `blk-init`. Bypass data are reported asynchronously, and they are supported by the bypass queue.

Load misses are kept in the load miss (LSM) queue, which is shared by other opcodes such as atomics and prefetch. The LSM queue supports one outstanding load miss per thread. Load misses with duplicated physical addresses (PA) will not be sent to the level 2 (L2) cache.

Inbound packets from the CCX are queued and ordered for distribution to other units through the data fill queue (DFQ).

The DTLB is fully associative, and it is responsible for the address translations. All CAM/RAM translations are single-cycle operations.

The ASI operations are serialized through the LSU. They are sequenced through the ASI queue to the destination units on the chip.

[FIGURE 2-14](#) illustrates the LSU data flow concept.

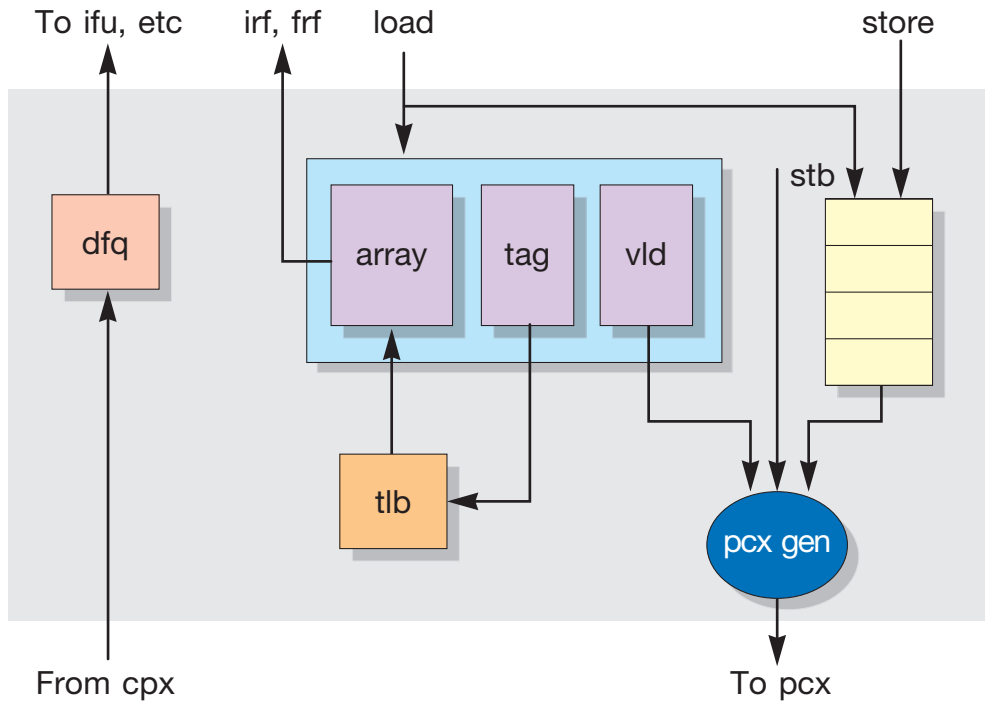

FIGURE 2-14 LSU Data Flow Concept

2.4.3 Level 1 Data Cache (D-Cache)

The 8-Kbyte level 1 (L1) D-cache is 4-way set-associative, and the line size is 16 bytes. The D-cache has a single read and write port (1 RW) for the data and tag array. The valid bit (V-bit) array is dual ported with one read port and one write port (1R/1W). The valid bit array holds the cache line state of valid or invalid. Invalidation access the V-bit array directly without first accessing the data and tag array. The cache line replacement policy follows a pseudo-random algorithm, where loads are allocating and stores non-allocating.

A cacheable load-miss will allocate a line, and it will execute the write-through policy for stores. Stores do not allocate, and local stores may update the L1 D-cache if it is present in the L1 D-cache, as determined by L2 (Level 2) cache directory. If it is deemed that it is not present in L1 D-cache, the local stores will cause the lines to become invalidated. The line replacement policy is pseudo random based on a linear shift register. The data from the bypass queues will be multiplexed into the L1 D-cache in order to be steered to the intended destination. The D-cache supports up to four simultaneous invalidates from the data evictions.

The L2-cache is always inclusive of the L1 D-cache. The exclusivity of the D-cache dictates that a line present in the L1 D-cache will not be present in the L1 I-cache. The data valid array is dual ported with one read port and one write port (1R1W).

Each line in the L1 D-cache is parity protected. A parity error will cause a miss in the L1 D-cache which, in turn, will cause the correct data to be brought back from the L2-cache.

In addition to the pipeline reads, the L1 D-cache can also be accessed by way of diagnostic ASI operations, BIST operations, and RAMtest operations through the test access port (TAP).

2.4.4 Data Translation Lookaside Buffer

The data translation lookaside buffer (DTLB) is the TLB for the D-cache. The DTLB caches up to the 64 most-recently-accessed translation table entries (TTE) in a fully associative array. The DTLB has one CAM port and one read-write port (1 RW). All four threads share the DTLB. The translation table entries of each thread are kept mutually exclusive from the entries of the other threads.

The DTLB supports the following 32-bit address translation operations:

- VA -> PA [virtual address (VA) to physical address (PA) translation]
- VA = PA [address bypass for hypervisor mode operations]
- RA -> PA [Real Address (RA) to Physical Address (PA) bypass translation for supervisor mode operations]

The TTE tag and the TTE data are both parity protected and errors are uncorrectable. TTE access parity errors for load instructions will cause a precise trap. TTE access parity errors for store instructions will cause a deferred trap (that is, the generation of the trap will be deferred to the instruction following the store instruction). However, the trap PC delivered to the system software still points to the store instruction that encountered the parity error in the TTE access. Therefore, the deferred action of the trap generation will still cause a precise trap from the system software perspective.

2.4.5 Store Buffer

The physical structure of the store buffer (STB) consists of a store buffer CAM (SCM) and a store buffer data array (STBDATA). Each thread is allocated with eight fixed entries in the shared data structures. The SCM has one CAM port and one RW port, and the STBDATA has one read (1R) port and one write (1W) port.

All stores reside in the store buffer until they are ordered following a total store ordering (TSO) model and have updated the L1D (level 1 D-cache). The lifecycle of a TSO compliant store follows these four stages:

1. Valid
2. Commit (issued to L2-cache)
3. Acknowledged (L2-cache sent response)
4. Invalidated or L1D updated

Non-TSO complaint stores, such as blk-init and other flavors of bst (block store), will not follow the preceding life-cycle. A response from the L2-cache is not required before releasing the non-TSO complaint stores from the store buffer.

Atomic instructions such as CAS, LDSTUB, and SWAP, as well as flush instructions, can share the store buffer.

The store buffer implements partial and full read after write (RAW) checking. Full-RAW data will be returned to the register files from the pipe. Partial RAW hits will force the load to access the L2-cache while interlocked with the store issued to the CCX. Multiple hits in the store buffer will always force access to the L2-cache in order to enforce data consistency.

If a store hits any part of a quad-load (16-byte access), the quad-load checking will force the serialization of the issue to the CCX. This forced serialization enforces that there will be no bypass operation.

Instructions such as a blk-load (64-byte access) will not detect the potential store buffer hit on the 64-byte boundary. The software must guarantee the data consistency using membar instructions.

2.4.6 Load Miss Queue

The load miss queue (LMQ) contains four entries in its physical structure, and the queue supports up to one load miss per thread. Instructions similar to load (such as atomics and prefetches) may also reside in the load miss queue.

A load instruction speculates on a D-cache miss to reduce the latency in accessing the CCX. The load instruction may also speculate on the availability of a queue entry in the CCX. If the speculation fails, the miss-speculated load instruction can be replayed out of LMQ.

Load requests to the L2-cache from different addresses can alias to the same L2-cache line. Primary versus secondary checking will be performed in order to prevent potential duplication in the L2-cache tags.

The latencies for completing different load instructions may differ (for example, a quad-load fill will have to access integer register file (IRF) twice).

The LMQ is also leveraged by other instructions. For example, the first packet of a CAS instruction will be issued out of the store buffer while the second packet will be issued out the LMQ.

2.4.7 Processor to Crossbar Interface Arbiter

The processor-to-crossbar interface (PCX) is the interface between the processor and the CCX. The arbiter takes on 13 sources to produce one arbitrated output in one cycle. The 13 sources include – four load-type instructions, four store-type instructions, one instruction cache (I-cache) fill, one floating-point unit (FPU) access, one stream processing unit (SPU) access, one interrupt, and one forward-packet.

The 13 sources are further divided into four categories of different priorities. The I-cache miss handling is one category. The load instructions (one outstanding per thread) are in one category. The store instructions (one outstanding per thread) are in another category. The rest of accesses are lumped into one category, and include – the FPU access, SPU access, interrupt, and the forward-packet.

The arbitration is done within the category first and then among the other categories. An I-cache fill is at the highest priority, while all other categories have an equal priority. The priorities can be illustrated in this order:

1. I-cache miss
2. Load miss
3. Stores
4. {FPU operations, SPU operations, Interrupts}

The use of a two-level history allows a fair, per-category scheduling among the different categories. The arbiter achieves a resolution in every cycle. Requests from atomic instructions take two cycles to finish the arbitration.

There are five possible targets, which include four L2-cache banks and one I/O buffer (IOB). The FPU access shares the path through the IOB.

Speculation on the PCX availability does occur, and a history will be established once the speculation is known to be correct.

2.4.8 Data Fill Queue

A SPARC core communicates with memory and I/O using packets. The incoming packets, destined to a SPARC core, are queued in the data fill queue (DFQ) first. These packets can be acknowledgement packets or data packets from independent sources. The DFQ maintains a predefined ordering requirement for all the inbound packets. The targets for the DFQ to deliver the packets to include the instruction fetch unit (IFU), load store unit (LSU), trap logic unit (TLU), and stream processing unit (SPU).

A store to the D-cache is not allowed to bypass another store to the D-cache. Store operations to different caches can bypass each other without violating the total store ordering (TSO) model.

Interrupts are allowed to be delivered to TLU only after all the prior invalidates have been visible in their respective caches. An acknowledgement to a local I-flush is treated the same way as an interrupt.

Streaming stores will be completed to the D-cache before the acknowledgement is sent to the SPU.

2.4.9 ASI Queue and Bypass Queue

Certain SPARC core internal alternate space identifier (ASI) accesses, such as the long latency MMU ASI transactions and all IFU ASI transactions, are queued in the ASI queue. The ASI queue is a FIFO that supports one outstanding ASI transaction per thread. For all read-type ASI transactions, regardless whether they originated from the LSU or not, must have their the return data routed through the LSU and be delivered to the register file by way of the bypass queue.

The bypass queue handles all of the load reference data, other than that received from the L2-cache, that must be asynchronously written to the integer register file (IRF). This kind of *read* data includes full-RAW data from the store buffer, *ldxa* to the internal ASI data, store data for *casa*, a forward packet for the ASI transactions, as well as the pending precise traps.

2.4.10 Alternate Space Identifier Handling in the Load Store Unit

In addition to sourcing alternate space identifier (ASI) data to other functional units of a SPARC core, the load store unit (LSU) decodes and supports a variety of ASI transactions, which include:

- Defining the behavior of ld/st ASI transactions such as blk-ld, blk-st, quad-ASI, and so on
- Defining an explicit context for address translation at all levels of privilege, such as primary, secondary, as_if_user, as_if_supv, and so on
- Defining special attributes, such as non_faulting and endianness, and so on
- Defining address translation bypassed, such as [RA=PA], [VA=PA], and so on, where VA stands for virtual address, PA stands for physical address, and RA stands for real address

2.4.11 Support for Atomic Instructions (CAS, SWAP, LDSTUB)

CAS is issued as a two-packet sequence to the Processor to L2-cache Interface (PCX). Packet 1 contains the compare address (rs1) and the data (rs2). Packet 2 contains the swap data (rd). Packet 1 resides in the store buffer in order to be compliant to the TSO ordering, while Packet 2 occupies the thread's entry into the load miss queue (LMQ).

Packet 1 and Packet 2 are issued in back-to-back order to the PCX. An acknowledgement to the load is returned to the CPX in response to Packet 1. This acknowledgment contains the data in memory from the address-in (rs1). An acknowledgement to the store is returned on the CPX in response to Packet 2. This acknowledgment will cause an invalidation at address-in (rs1) if the cache line is present in the level 1 D-cache.

SWAP and LDSTUB are single packet requests to the PCX, and they reside in the store buffer.

2.4.12 Support for MEMBAR Instructions

MEMBAR instructions ensure that the store buffer of a thread has been drained before the thread gets switched back in. The completion of draining the store buffer implies that all stores prior to the MEMBAR instruction have reached a global visibility, in compliance with TSO ordering. Before a MEMBAR is released, it ensures that all blk-init and blk-st instructions have also reached global visibility. This is accomplished by making sure that *st-ack* counter has been cleared.

There are several flavors of MEMBAR instructions. The implementation for #storestore, #loadstores, and #loadload is to make them behave like NOPs. The implementation for #storeload, #memissue, and #lookaside is to make them to behave like #sync. *membar #sync* is fully implemented to help enforce the compliance to TSO ordering.

A parity error on a store to the DTLB will cause a deferred trap. It will be reported on the follow-up *membar #sync*. The trap PC in this case will point to the store instruction encountering the parity error when storing to the DTLB. The deferred trap will look like a precise trap to the system software because of the way the hardware supports the recording of the precise trap PC.

2.4.13 Core-to-Core Interrupt Support

A core-to-core interrupt is initiated by a write to the interrupt dispatch register IINT_VEC_DIS ASI in Trap Logic Unit (TLU). It will generate a request to LSU for access to PCX. LSU only supports one outstanding interrupt request at any time.

An interrupt is treated similar to a membar. It will be sent to PCX once the store buffer of the corresponding thread has been drained. This interrupt will then immediately be acknowledged to TLU.

After the interrupt packet has been dispatched by way of the L2-cache to Core Interface (CCX), the packet would be executed on the destination thread of a SPARC core. It can be invalidated after all prior invalidates have completed and results arrived at L1 D-cache (L1D).

2.4.14 Flush Instruction Support

A flush instruction does not actually flush the instruction memory. It instead, it acts as a barrier to ensure that all of the prior invalidations for a thread have been visible in the level 1 I-cache (L1I) before causing the thread to be switched back in.

The flush is issued as an interrupt with the flush bit set, which causes the L2-cache to broadcast the packet to all SPARC cores.

For the SPARC core that issued the flush, an acknowledgement from the DFQ upon receiving the packet will cause all of the prior invalidations to complete with the results arrived at the level 1 I-cache and the level 1 D-cache (L1 I/D).

For the SPARC cores that did not issue the flush, the DFQ will serialize the flushes so that the order of the issuing threads actions, relative to the flushes, will be preserved.

2.4.15 Prefetch Instruction Support

A prefetch instruction is treated as a non-cacheable load. A prefetch that misses in the TLB, or accesses I/O space, will be treated as a NOP. The issuing thread will be switched back in without accessing the processor to L2-cache interface (PCX).

The LSU supports a total of eight outstanding prefetch instructions across all four threads. The LSU keeps track of the number of outstanding prefetches per thread, which limits the number of outstanding prefetches.

2.4.16 Floating-Point BLK-LD and BLK-ST Instructions Support

Floating-point blk-ld and blk-st instructions are non-TSO compliant. Only one outstanding blk-ld or blk-st instruction is allowed per SPARC core. These instructions will bypass the level 1 caches and will not allocate in the level 1 caches either. On a level 1 D-cache (L1D) hit, a blk-st instruction will cause an invalidation to the L1D. Both blk-st and blk-ld instructions can access the memory space and the I/O space.

The LSU breaks up a the 64-byte packet of a blk-ld instruction into four of 16-byte load packets so that they can access the processor and L2-cache interface (PCX). The Level 2 cache returns four of the 16-byte packets, which in turn, will cause eight of 8-byte data transfers to the floating-point register file (FRF). Errors are reported on the last packet. A blk-ld instruction could cause a partial update to the FRF. Software must be written to retry the instruction later.

A blk-st instruction will be unrolled into eight helper instructions by the floating-point functional unit (FFU) for a total of a 64-byte data transfer. Each 8-byte data gets an entry of the corresponding thread in the store buffer. The blk-st instructions are non-TSO compliant, so the software must do the ordering.

2.4.17 Integer BLK-INIT Loads and Stores Support

The blk-init load and blk-init store instructions were introduced as the substitute for blk-ld and blk-st in block-copy routines. They can access both the memory space and the I/O space. The blk-init loads do not allocate in the level 1 D-cache. On a level 1 D-cache hit, the blk-init stores will invalidate the level 1 D-cache (L1D).

The blk-init load instructions must be quad-word accesses, and violating this rule will cause a trap. Like quad-load instructions, blk-init loads also send double-pump writes (8-byte access) to the integer register file (IRF) when a blk-init load packet reaches the head of the data fill queue (DFQ).

The blk-init stores are also non-TSO compliant, which allows for greater write throughput and higher-performance yields for the block-copy routine.

Up to only eight of all non-TSO compliant instructions can be allowed outstanding for each SPARC core. The LSU keeps a counter per thread to enforce this limit.

2.4.18 STRM Load and STRM Store Instruction Support

Instructions such as strm-ld and strm-st make requests from the stream processing unit (SPU) to memory by way of the LSU.

The Store buffer will not be looked-up by the strm-ld instructions, and the store buffer will not buffer strm-st data. Software must be written to enforce the ordering and the maintenance of the data coherency.

The acknowledgements for strm-st instructions will be ordered through the data fill queue (DFQ) upon the return to the stream processing unit (SPU). The corresponding store acknowledgement (st ack) will be sent to the SPU once the level 1 D-cache (L1D) invalidation, if any, has been completed.

2.4.19 Test Access Port Controller Accesses and Forward Packets Support

Test access port (TAP) controller can access any SPARC core by way of the SPARC interface of the I/O bridge (IOB). A forward request to the SPARC core might take any of the following actions:

- Read or write level 1 I-cache or D-cache
- Read or write BIST control
- Read or write margin control
- Read or write de-feature bits to the de-feature any, or all, of L1I, L1D, ITLB, DTLB in order to take a cache off-line, or a TLB offline, for diagnostic purposes

A forward reply will be sent back to the I/O bridge (IOB) once the data is read or written. A SPARC core might further forward the request to the L2-cache for an access to the control status register (CSR). The I/O bridge only supports one outstanding forward access at any time.

2.4.20 SPARC Core Pipeline Flush Support

A SPARC core pipeline flush is reported through the LSU since the LSU is the source of the latest traps in the pipeline.

The trap logic unit (TLU) gathers traps from all functional units except the LSU, and it then sends them to the LSU. the LSU performs the *or* function for all of them (plus its own) and then it broadcasts across the entire chip.

The LSU can also send a truncated flush for the internal ASI ld/st to the TLU, the MMU, and the SPU.

2.4.21 LSU Error Handling

Errors can be generated from any, or all, of the following memory arrays – DCACHE (D-cache), D-cache tag array (DTAG), D-cache valid bit array (DVA), DTLB, data fill queue (DFQ), store buffer CAM array (SCM), and store buffer data array (STBDATA). Only the DCACHE, DTAG, and DTLB arrays are parity protected.

- A parity error on a load reference to the DCACHE will be corrected by way of the reloading the correct data from the L2-cache as if there were a D-cache miss.
- A DTAG parity error will result in a correction packet, followed by the actual load request, to the L2-cache. The correction packet synchronizes the L2 directory and the L1 D-cache set. On the load request acknowledgement, the level 1 D-cache will be filled.
- A parity error on the DTLB tte-data will cause an uncorrectable error trap to the originating loads or stores.
- A parity error on the DTLB tte-data can also cause an uncorrectable error trap for ASI reads.
- A parity error on the DTLB tte-tag can only cause an uncorrectable error trap for ASI reads.

2.5 Execution Unit

The execution unit (EXU) contains these four subunits – arithmetic and logic unit (ALU), shifter (SHFT), integer multiplier (IMUL), and integer divider (IDIV).

FIGURE 2-15 presents a top level diagram of the execution unit.

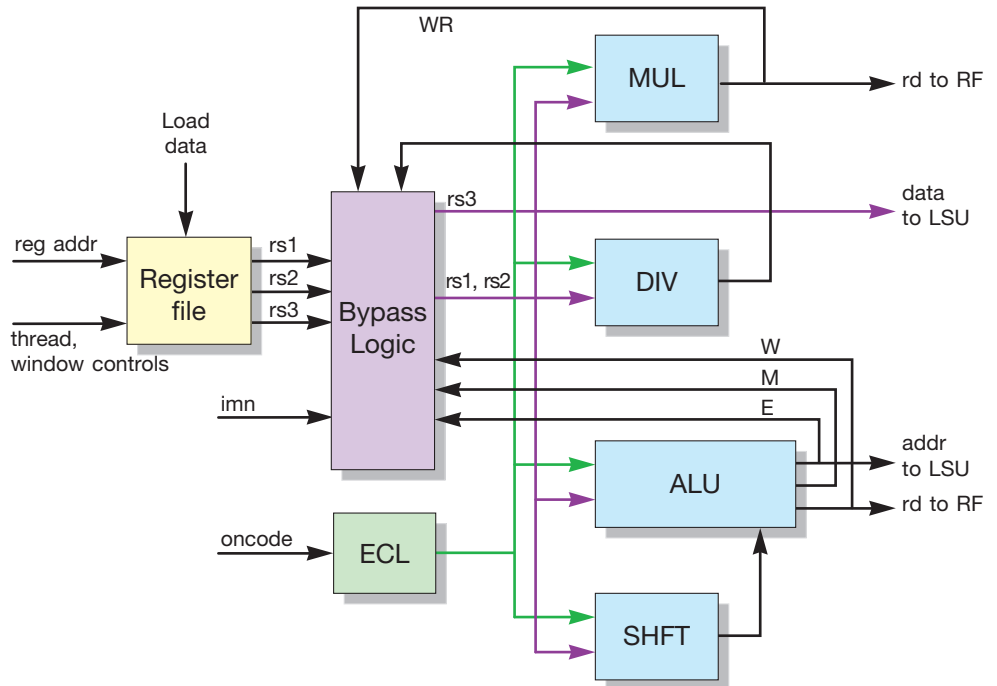

FIGURE 2-15 Execution Unit Diagram

The execution control logic (ECL) block generates the necessary select signals that control the multiplexors, keeps track of the thread and reads of each instruction, and implements the bypass logic. The ECL also generates the write-enables for the integer register file (IRF). The bypass logic block does the operand bypass from the E, M, and W stages to the D stage. Results of long latency operations such as load, mul, and div, are forwarded from the W stage to the D stage. The condition codes are bypassed similar to the operands, and bypassing of the FP results and writes to the status registers are not allowed.

The shifter block (SHFT) implements the 0 - 63-bit shift, and FIGURE 2-16 illustrates the top level block diagram of the shifter.

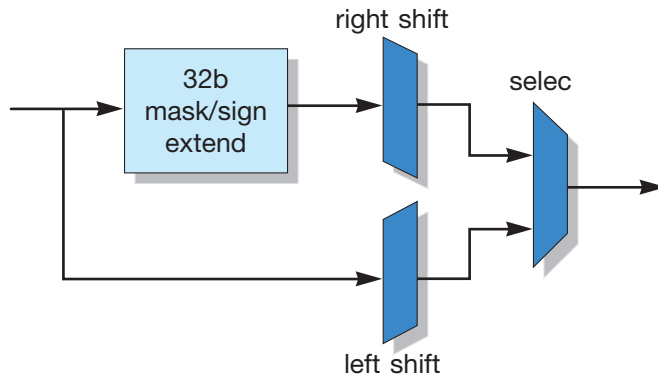

FIGURE 2-16 Shifter Block Diagram

The arithmetic and logic unit (ALU) consists of an adder and logic operations such as – ADD, SUB, AND, NAND, OR, NOR, XOR, XNOR, and NOT. The ALU is also reused when calculating the branch address or a virtual address. [FIGURE 2-17](#) illustrates the top level block diagram of the ALU.

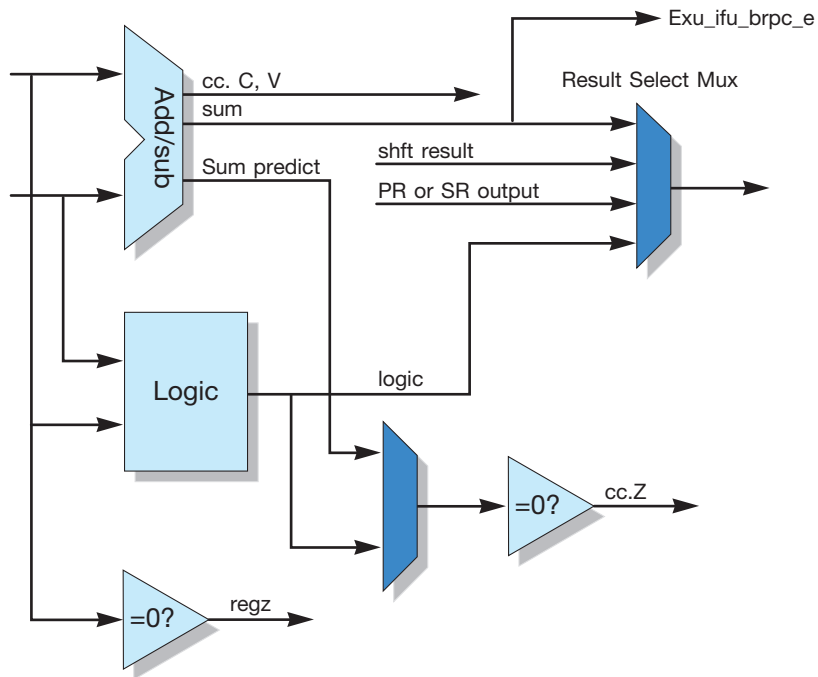

FIGURE 2-17 ALU Block Diagram

MUL is the integer multiplier unit (IMUL), and DIV is the integer divider unit (IDIV). IMUL includes the accumulate function for modular arithmetic. The latency of IMUL is 5 cycles, and the throughput is 1-half per cycle. IMUL supports one outstanding integer multiplication operation per core, and it is shared between a SPARC core pipeline and the modular arithmetic unit (MAU). The arbitration is based on a round-robin algorithm.

IDIV contains a simple non-restoring divider, and it supports one outstanding divide operation per core.

FIGURE 2-18 illustrates the top level diagram of the IDIV.

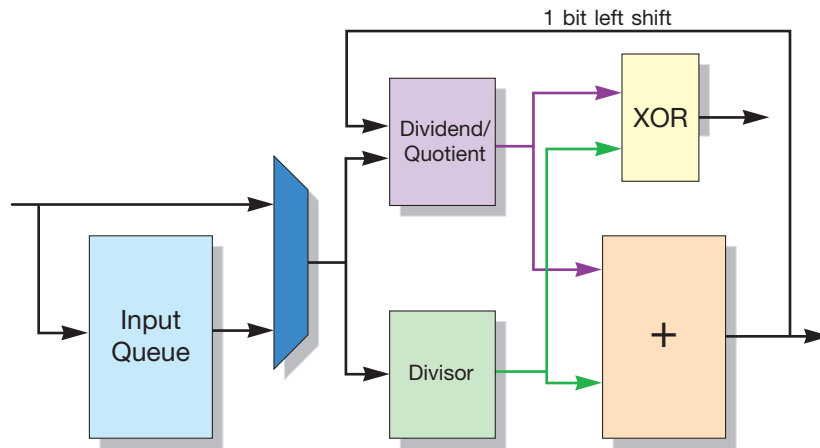

FIGURE 2-18 IDIV Block Diagram

When either IMUL or IDIV is occupied, a thread issuing a MUL or DIV instruction will be rolled back and switched out.

2.6 Floating-Point Frontend Unit

2.6.1 Functional Description of the FFU

The floating-point frontend unit (FFU) is responsible for dispatching floating-point operations (FP ops) to the floating-point unit (FPU) through the LSU, as well as executing simple FP ops (mov, abs, neg) and VIS instructions. The FFU also maintains the floating-point state register (FSR) and the graphics state register (GSR). There can be only one outstanding instruction in the FFU at a time.

The FFU is composed of four blocks – the floating-point register file (FFU_FRF), the control block (FFU_CTL), the data-path block (FFU_DP), and the VIS execution block (FFU_VIS). [FIGURE 2-19](#) shows a block diagram of the FFU illustrating these four sub-blocks.

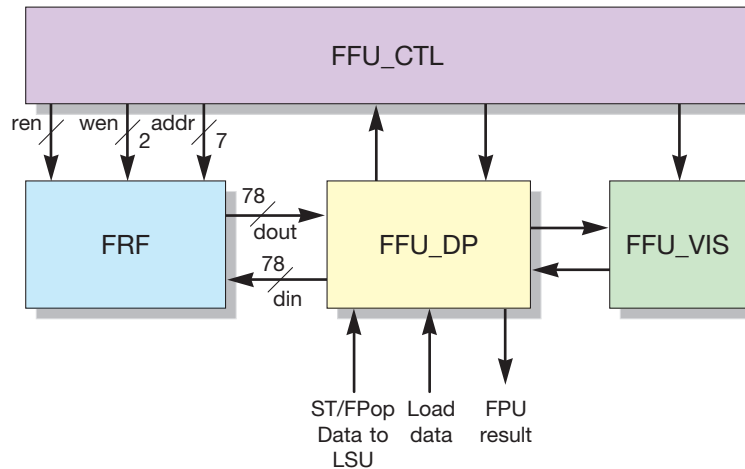

FIGURE 2-19 Top-Level FFU Block Diagram

2.6.2 Floating-Point Register File

The floating-point register file (FRF) has 128 entries of 64-bits of data, plus 14-bits of ECC. The write port has an enable for each half of the data. Bits [38:32] are the ECC bits for the lower word (data[31:0]) and bits [77:71] are the ECC bits for the upper word (data[70:39]).

2.6.3 FFU Control (FFU_CTL)

The FFU control (FFU_CTL) block implements the control logic for the FFU, and it generates the appropriate multiplexor selects and data-path control signals. The FFU control also decodes the *fp_opcode* and contains the state machine for the FFU pipeline. It also generates the FP traps and kill signals, as well as signalling the LSU when the data is ready for dispatch.

2.6.4 FFU Data-Path (FFU_DP)

This FFU data-path block contains the multiplexors and the flops for the data that has been read from, or is about to be written to, the FRF. The FFU data-path also dispatches the data for the STF and the FPops to the LSU, receives LDF from the LSU, and receives the results from the FPops from the CPX. The FFU data-path also implements FMOV, FABS, and FNEG, checks the ECC for the data read from the FRF, and generates the ECC for the data written to the FRF.

2.6.5 FFU VIS (FFU_DP)

The FFU VIS (FFU_DP) block implements a subset of the VIS graphics instructions, including partitioned addition/subtraction, logical operations, and falignedata. All the operations are implemented in a single cycle, and the data inputs and outputs are connected to the FFU_DP.

2.7 Multiplier Unit

2.7.1 Functional Description of the MUL

The SPARC multiplier unit (MUL) performs the multiplication of two 64-bit inputs. The MUL is shared between the EXU and the SPU, and it has a control block and data-path block. [FIGURE 2-20](#) shows how the multiplier is connected to other functional blocks.

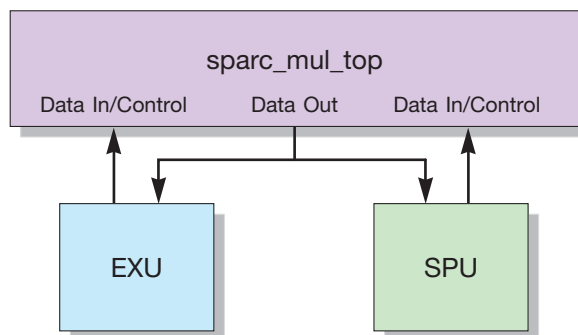

FIGURE 2-20 Multiplexor (MUL) Block Diagram

2.8 Stream Processing Unit

Each SPARC core is equipped with a stream processing unit (SPU) supporting the asymmetric cryptography operations (public-key RSA) for up to a 2048-bit key size.

The SPU shares the integer multiplier with the execution unit (EXU) for the modular arithmetic (MA) operations. The SPU itself supports full modular exponentiation. While the SPU facility is shared among all threads of a SPARC core, only one thread can use the SPU at a time. The SPU operation is set up by a storing a thread to a control register and then returning to normal processing. The SPU will initiate streaming load or streaming store operations to the level 2 cache (L2) and compute operations to the integer multiplier. Once the operation is launched, it can operate in parallel with SPARC core instruction execution. The completion of the operation is detected by polling (synchronous fashion) or by interrupt (asynchronous fashion).

2.8.1 ASI Registers for the SPU

All alternate space identifier (ASI) registers for the SPU are 8 bytes in length. Access to all of the ASI registers for the SPU have hypervisor privilege, so they can only be accessed in hypervisor mode. The following list highlights those ASI registers.

- Modular arithmetic physical address (MPA) register

This register carries the physical address used to access the main memory. MA_LD requests must be on the 16-byte boundary while MA_ST requests must be on the 8-byte boundary.

- Modular arithmetic memory addresses (MA_ADDR) register

This register carries the memory address offsets for various operands, and the size of the exponent. [FIGURE 2-21](#) highlights the layout of the bit fields.

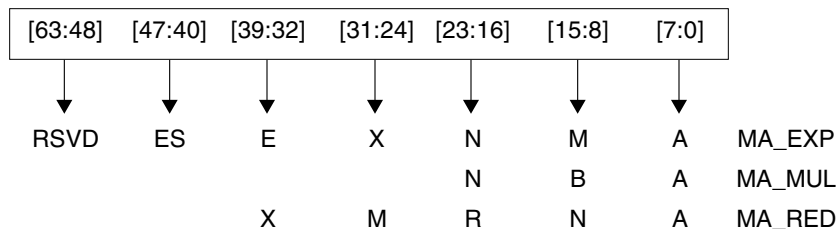

FIGURE 2-21 Layout of MA_ADDR Register Bit Fields

- Modular arithmetic N-prime value (MA_NP) register

This register is used to specify the modular arithmetic N-prime value.

- Modular arithmetic synchronization (MA_SYNC) register

A load operation from this register is used to synchronize a thread with the completion of asynchronous modular arithmetic operations performed by the SPU.
- Modular arithmetic control parameters (MA_CTL) register

This register contains several bit-filed fields that provide these control parameters:

 - PerrInj – Parity error injection

When this parameter is set, each operation that writes to modular arithmetic memory will have the parity bit inverted.
 - Thread – Thread ID for receiving interrupt

If the Int bit is set, this set of bits specifies the thread that will receive the disrupting trap on the completion of the modular arithmetic operation.
 - Busy – SPU is BUSY

When this parameter is set, the SPU is busy working on the specified operation.
 - Int – Interrupt enable

When this parameter is set, the SPU will generate a disrupting trap to the current thread on completion of the current modular arithmetic operation. If cleared, software can synchronize with the current modular arithmetic operation using the MA_Sync instruction.

The disrupting trap will use the *implementation_dependent_exception_20* as the modular arithmetic interrupt.
 - Opcode – Operation code of modular arithmetic operation (see [TABLE 2-3](#))

TABLE 2-3 Modular Arithmetic Operations

Opcode Value	Modular Arithmetic Operation
0	Load from modular arithmetic memory
1	Store to modular arithmetic memory
2	Modular multiply
3	Modular reduction
4	Modular exponentiation loop
5-7	Reserved

- Length – Length of modular arithmetic operations

This field contains the bits for the value of the (length - 1) for the modular arithmetic operations.

2.8.2 Data Flow of Modular Arithmetic Operations

FIGURE 2-22 illustrates the data flow of modular arithmetic operations.

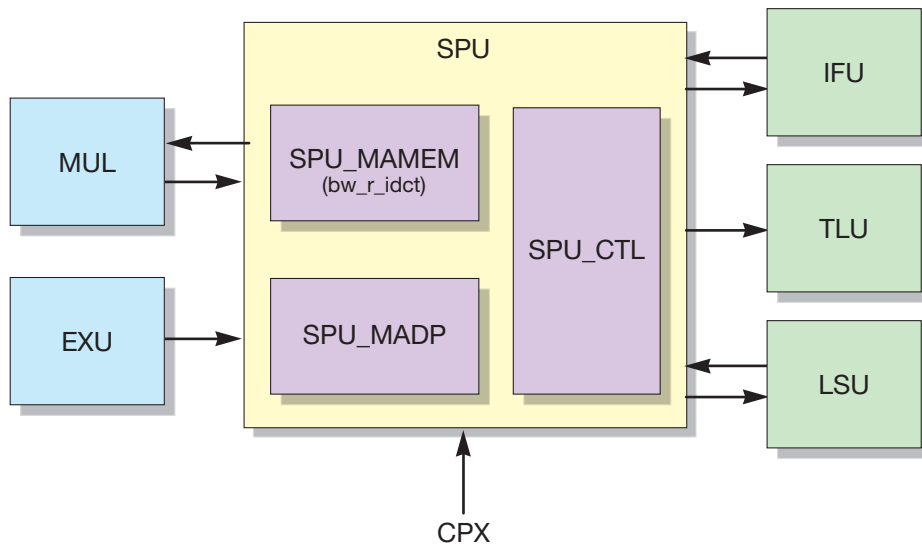

FIGURE 2-22 Data Flow of Modular Arithmetic Operations

2.8.3 Modular Arithmetic Memory (MA Memory)

A total of 1280 bytes of local memory with a single read/write port (1RW) is used to supply operands to modular arithmetic operations. The modular arithmetic memory (MA memory) will house 5 operands with 32 words each, which supports a maximum key size of 2048 bits. This MA memory is parity protected with a 2-bit parity for each 64-bit word.

MA memory requires software initialization prior to the start of MA memory operations. Three MA_LD operations are required to initialize all 160 words of memory because the MA_CTL length field allows up to 64 words to be loaded into MA memory.

Write accesses to the MA memory can be on either the 16-byte boundary or the 8-byte boundary. Read accesses to the MA memory must be on the 8-byte boundary.

2.8.4 Modular Arithmetic Operations

All modular arithmetic registers must be initialized prior to launching a modular arithmetic operation. Modular arithmetic operations (MA ops) start with a stxa to the MA_CTL register if the store buffer for that thread is empty. Otherwise, the thread will wait until the store buffer is emptied before sending stx_ack to the LSU. An MA operation that is in progress can be aborted by another thread by way of a stx to the MA_CTL register.

An ldx to MA registers are blocking. All except ldx to the MA_Sync register will respond immediately. An ldx to the MA_Sync register will return a 0 to the destination register upon the operation completion. The thread ID of this ldx should be equal to that stored in the thread ID field of the MA_CTL register. Otherwise, the SPU will respond immediately and send signals to the LSU to not update the register file. In case of aborting an MA operation, the pending ldx to MA_Sync is unblocked, and the SPU signals the LSU will not update the register file.

FIGURE 2-23 illustrates the MA operations using a state transition diagram.

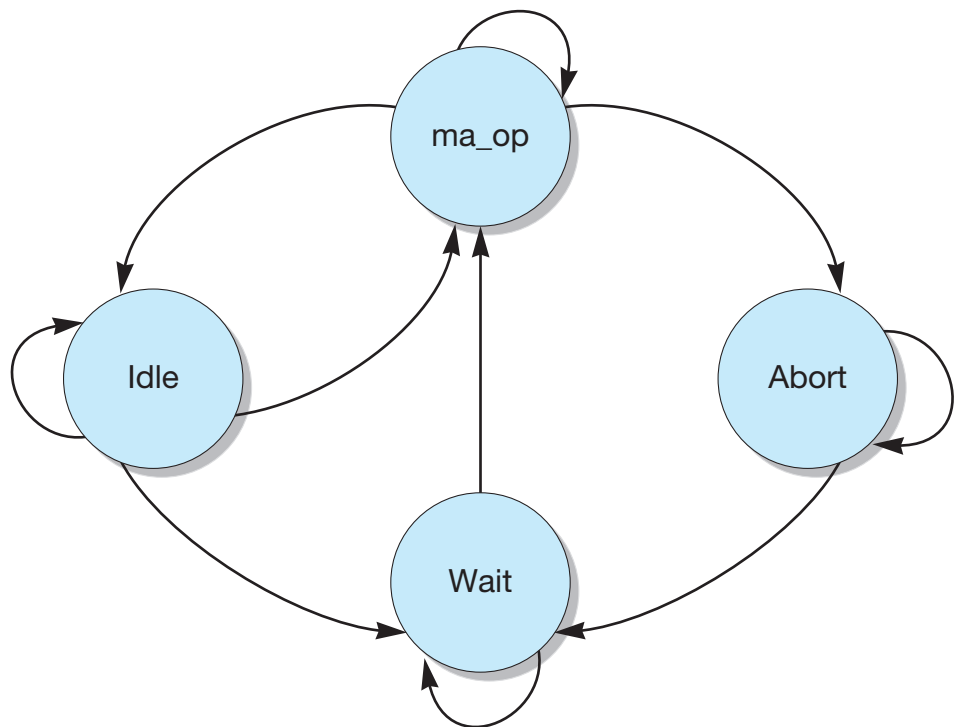

FIGURE 2-23 State Transition Diagram Illustrating MA Operations

The state transitions are clarified by the following set of equations:

```
tr2_maop_frm_idle = cur_idle & stxa_2ctlreq & ~wait_4stb_empty & ~wait_4trapack_set;
tr2_abort_frm_maop = cur_maop & stxa_2ctlreq;
tr2_wait_frm_abort = cur_abort & ma_op_complete;
tr2_maop_frm_wait = cur_wait & ~(stxa_2ctlreq | wait_4stb_empty | wait_4trapack_set);
tr2_idl_frm_maop = cur_maop & ~stxa_2ctlreq & ma_op_complete;
tr2_wait_frm_idle = cur_idle & stxa_2ctlreq & (wait_4stb_empty | wait_4trapack_set);
```

A MA_ST operation is started with a stxa to the MA_CTL register opcode equals the MA_ST, and the length field specifies the number of words to send to the level 2 cache (L2-cache). The SPU sends a processor to cache interface (PCX) request to the LSU and waits for an acknowledgement from the LSU prior to sending another request. If needed, store acknowledgements, which are returned from the L2-cache on level 2 cache to processor interface (CPX), will go to the LSU in order to invalidate the level 1 D-cache (L1D). The LSU will then send the SPU an acknowledgement. The SPU then decrements a local counter and waits for all the stores sent out to be acknowledged and transitioned to the done state.

On a read from the MA Memory, the operation will be halted if a parity error is encountered. The SPU waits for all posted stores to be acknowledged. If the Int bit is cleared (Int = 0), the SPU will signal the LSU and the IFU on all ldx to the MA registers.

An MA_LD operation is started with a stxa to MA_CTL register opcode equals MA_LD, and the length field specifies the number of words to be fetched from the L2-cache. The SPU sends a PCX request to the LSU and waits for an acknowledgement from the LSU before sending out another request. The L2-cache returns data to the SPU directly on CPX.

Any data returned with an uncorrectable error will halt the operation. If the Int bit is cleared (Int = 0), the SPU will send a signal to the LSU and the IFU on any ldx to MA register.

Any data returned with a correctable error will cause the error address to be sent to IFU and be logged, while the operation will continue until completion.

TABLE 2-4 illustrates the error handling behavior.

TABLE 2-4 Error Handling Behavior

NCEEN	Int	LSU	IFU
0	0	-	error_log
0	1	-	error_log
1	0	precise trap	error_log
1	1	-	error_log

The MA_MUL, MA_RED, and the MA_EXP operations all started with a stxa to MA_CTL register with an opcode equal to the respective operation, and the length field specifies the number of 64-bit words for each operation. The maximum length of these operations should never exceed 32 words.

The MA_MUL operates on A, B, M, N and N operands. The result will be stored in the X operand.

The MA_RED operates on A and N operands and the result will be stored in the R operand.

The MA_EXP performs the inner loop of modular exponentiation of A, M, N, X, E, operands stored in the MA Memory. This is the binary approach where the MA_MUL, followed by MA_RED functions, are called and will have the results stored in X operand.

The parity error encountered on an operand read will cause the operation to be halted. The LSU and the IFU will be signaled.

FIGURE 2-24 shows a pipeline diagram that illustrates the sequence of the result generation of the multiply function.

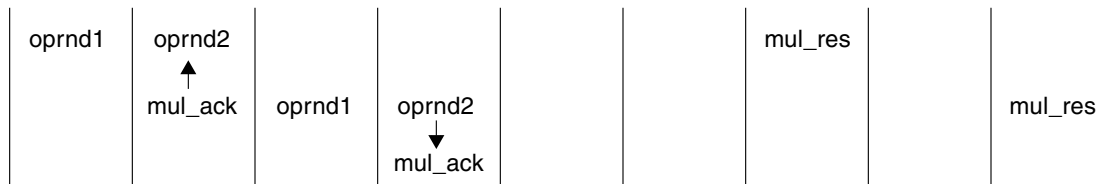

FIGURE 2-24 Multiply Function Result Generation Sequence Pipeline Diagram

2.9 Memory Management Unit

The memory management unit (MMU) maintains the contents of the instruction translation lookaside buffer (ITLB) and the data translation lookaside buffer (DTLB). The ITLB resides in instruction fetch unit (IFU), and the DTLB resides in load and store unit (LSU). FIGURE 2-25 shows the relationship among the MMU and the TLBs.

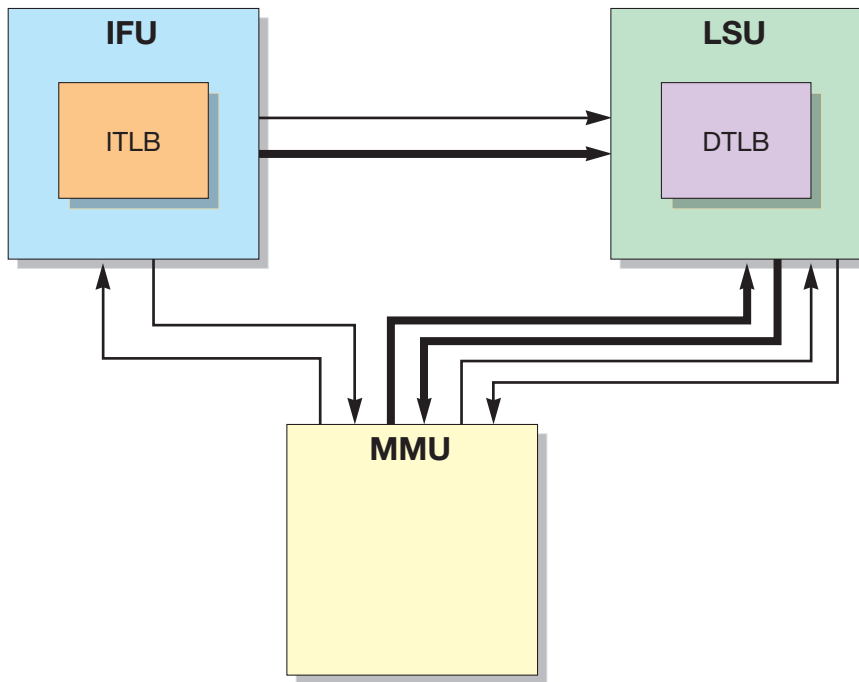

FIGURE 2-25 MMU and TLBs Relationship

2.9.1 The Role of MMU in Virtualization

The OpenSPARC T1 processor provides hardware support for the virtualization where multiple images and/or instances of the operating system (OS) coexist on top of the underlying chip multiple threading (CMT) microprocessor.

[FIGURE 2-26](#) illustrates the view of virtualization.

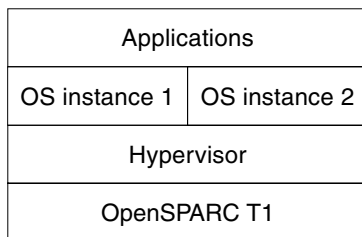

FIGURE 2-26 Virtualization Diagram

The hypervisor (HV) layer virtualizes the underlying central processing units (CPU). The multiple instances of the OS images form multiple partitions of the underlying virtual machine. The hypervisor improves the OS portability to the new hardware and insures that failure in one domain would not affect the operation in the other domains. The OpenSPARC T1 processor supports up to eight partitions, and the hardware provides 3 bits of partition ID in order to distinguish one partition from another.

The hypervisor (HV) layer uses physical addresses (PA) while the supervisor (SV) layer views real addresses (RA) where the RAs represent a different abstraction of the underlying PAs. All applications use virtual addresses (VA) to access memory. (The VA will be translated to RA and then to PA by TLBs and the MMU.)

2.9.2 Data Flow in MMU

The MMU interacts with TLBs to maintain the content of TLBs. The system software manages the content of MMU by way of three kinds of operations – reads, writes, and demap. All TLB entries are shared among the threads, and the consistency among the TLB entries is maintained through auto-demmap. The MMU is responsible for generating the pointers to the software translation storage buffers (TSB), and it also maintains the fault status for the various traps.

The access to the MMU is through the hypervisor-managed ASI operations such as `ldxa` and `stxa`. These ASI operations can be asynchronous or in-pipe, depending on the latency requirements. Those asynchronous ASI reads and writes will be queued up in LSU. Some of the ASI operations can be updated through faults or by a data access exception. Fault data for the status registers will be sent by trap logic unit (TLU) and the load and store unit (LSU).

2.9.3 Structure of Translation Lookaside Buffer

The translation lookaside buffer (TLB) consists of content addressable memory (CAM) and randomly addressable memory (RAM). CAM has one compare port and one read-write port (1C1RW), and RAM has one read-write port (1RW). The TLB supports the following mutually exclusive events.

1. CAM
2. Read
3. Write
4. Bypass
5. Demap

- 6. Soft-reset
- 7. Hard-reset

CAM consists of the following field of bits – partition ID (PID), real (identifies a RA-to-PA translation or a VA-to-PA translation), context ID (CTXT), and virtual address (VA). The VA field is further broken down to page-size based fields with individual enables. The CTXT field also has its own enable in order to allow the flexibility in implementation. The CAM portion of the fields are for comparison purposes. RAM consists of the following field of bits, namely, physical address (PA) and attributes. The RAM portion of the fields are for read purposes, where a read could be caused by a software read or a CAM based 1-hot read.

FIGURE 2-27 illustrates the structure of the TLB.

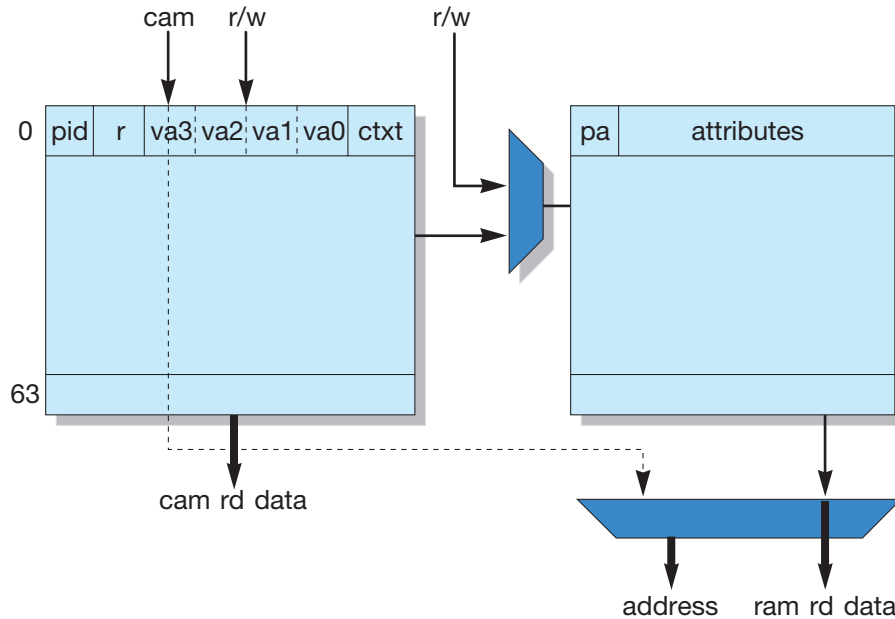

FIGURE 2-27 Translation Lookaside Buffer Structure

2.9.4 MMU ASI Operations

The types of regular MMU ASI operations are as follows:

- Writes
 - IMMU Data-In
 - DMMU Data-In
 - IMMU Data-Access
 - DMMU Data-Access
- Reads
 - IMMU Data-In
 - DMMU Data-In
 - IMMU Tag-Read
 - DMMU Tag-Read
- Demap
 - IMMU Demap Page
 - DMMU Demap Page
 - IMMU Demap Context
 - DMMU Demap Context
 - IMMU Demap All (cannot demap locked pages)
 - DMMU Demap All (cannot demap locked pages)
- Soft-Reset
 - IMMU Invalidate All (including locked pages)
 - DMMU Invalidate All (including locked pages)
- Fault Related ASI Accesses to Registers
 - IMMU Synchronous Fault Status Register (SFSR)
 - DMMU Synchronous Fault Status Register (SFSR)
 - DMMU Synchronous Fault Address Register (SFAR)
 - IMMU Tag Access
 - DMMU Tag Access
 - IMMU Tag Target
 - DMMU Tag Target
- ASI Accesses to Registers as Miss Handler Support
 - IMMU TSB Page Size 0
 - IMMU TSB Page Size 1
 - DMMU TSB Page Size 0
 - DMMU TSB Page Size 1
 - IMMU Context 0 TSB Page Size 0
 - IMMU Context 0 TSB Page Size 1
 - DMMU Context 0 TSB Page Size 0
 - DMMU Context 0 TSB Page Size 1
 - IMMU Context non-0 TSB Page Size 0
 - IMMU Context non-0 TSB Page Size 1

- DMMU Context non-0 TSB Page Size 0
- DMMU Context non-0 TSB Page Size 1
- IMMU Context 0 Config
- DMMU Context 0 Config
- IMMU Context non-0 Config
- DMMU Context non-0 Config

2.9.5 Specifics on TLB Write Access

A stxa to data-in or data-access causes a write operation that is asynchronous to the pipeline flow. Write requests are originated from the four-entry FIFO in the LSU. The LSU passes the write request to the MMU, which forwards it to the ITLB or the DTLB. A handshake from the target completes the write operation, which in turn enables the four-entry FIFO in the LSU to proceed with the next entry.

Write access to the data-in algorithmically places the translation table entry (TTE) in the TLB. Writes occur to the least significant unused entry. In contrast, write access to the data-access places the TTE in the specified entry in the TLB. For diagnostics purposes, a single bit parity error can be injected on writes.

A page may be specified as a real-on write, and a page will have a partition assigned to it on a write.

2.9.6 Specifics on TLB Read Access

TLB read operations follow the same handshake protocol as TLB write operations. The ASI data-access operations will read the RAM portion (that is, the TTE data). The ASI tag-read access operations will read the TTE tag from the RAM. The TLB read data will be returned to the bypass queue in the LSU. If no parity error is detected, the LSU will forward the data. Otherwise, the LSU will take a trap.

2.9.7 Translation Lookaside Buffer Demap

The system software can invalidate entries in the translation lookaside buffer (TLB) selectively using demap operations in any one of the following forms for the ITLB and the DTLB respectively and distinctly. Each demap operation is partition specific.

- Demap by page real – Match VA-tag and translate RA to PA
- Demap by page virtual – Match VA-tag and translate VA to PA
- Demap by context – Match context only (has no effect on real pages)
- Demap all – Demap all but the locked pages

The system software can clear the entire TLB distinctly through an invalidate all operation, which includes all of the locked pages.

2.9.8 TLB Auto-Demap Specifics

Each TLB is shared by all four threads. The OpenSPARC T1 processor provides a hardware auto-demap to prevent the threads from writing to overlapping pages. Each auto-demap operation is partition specific. The sequence of an auto-demap operation is as follows.

1. Schedule a write from the four entry FIFO in the LSU.
2. Construct an equivalent auto-demap key.
3. Assert demap and complete with a handshake.
4. Assert write and complete with a handshake.

2.9.9 TLB Entry Replacement Algorithm

Each entry has a *Used* bit. An entry is picked to be a candidate for a replacement if it is the least significant unused bit among all 64 entries.

A used bit can be set on a write, or on a CAM hit, or when locked. A locked page will have its used bit always set. An invalid entry has its used bit always cleared. All used bits will be cleared when the TLB reaches a saturation point (that is, when all entries have their used bit set while a new entry needs to be put in a TLB). If a TLB remains saturated because all of the entries have been locked, the default replacement candidate (entry 0x63) will be chosen and an error condition will be reported.

2.9.10 TSB Pointer Construction

An MMU miss will cause the write of the faulting address and the context in the tag access. The tag access has a context 0 copy or a context non-0 copy, which is updated depending on the context of the fault. The miss handler will read the pointer of page-size 0 or page-size 1. The hardware will continue with the following sequence in order to complete the operation.

1. Read `zero_ctxt_cfg` or `nonzero_ctxt_cfg` to determine the page size.
2. Read `zero_ctxt_tsb_base_ps0` or `zero_ctxt_tsb_base_ps1` on `nonzero_ctxt_tsb_base_ps0` or `nonzero_ctxt_tsb_base_ps1` to get the TSB base address and size of the TSB.
3. Access tag.

Software will then generate a pointer into the TSB based on the VA, the TSB base address, the TSB size, and the Tag.

2.10 Trap Logic Unit

The trap logic unit (TLU) supports six trap levels. A trap can be in one of the following four modes – reset-error-debug (RED) mode, hypervisor (HV) mode, supervisor (SV) mode, and user mode. Traps will cause the SPARC core pipeline to be flushed, and a thread-switch to occur, until the trap vector (redirect PC) has been resolved.

Software interrupts are delivered to each of the virtual cores using the *interrupt_level_n* trap through the `SOFTINT_REG` register. I/O and CPU cross-call interrupts are delivered to each virtual core using the *interrupt_vector* trap. Up to 64 outstanding interrupts can be queued up per thread—one for each interrupt vector. Interrupt vectors are implicitly prioritized, with vector 0x63 being at the highest priority, while vector 0x0 is at the lowest priority. Each I/O interrupt source has a hardwired interrupt number that is used as the interrupt vector by the I/O bridge block.

The TLU is in a logically central position to collect all of the traps and interrupts and forward them. [FIGURE 2-28](#) illustrates the TLU role with respect to all other backlogs in a SPARC core.

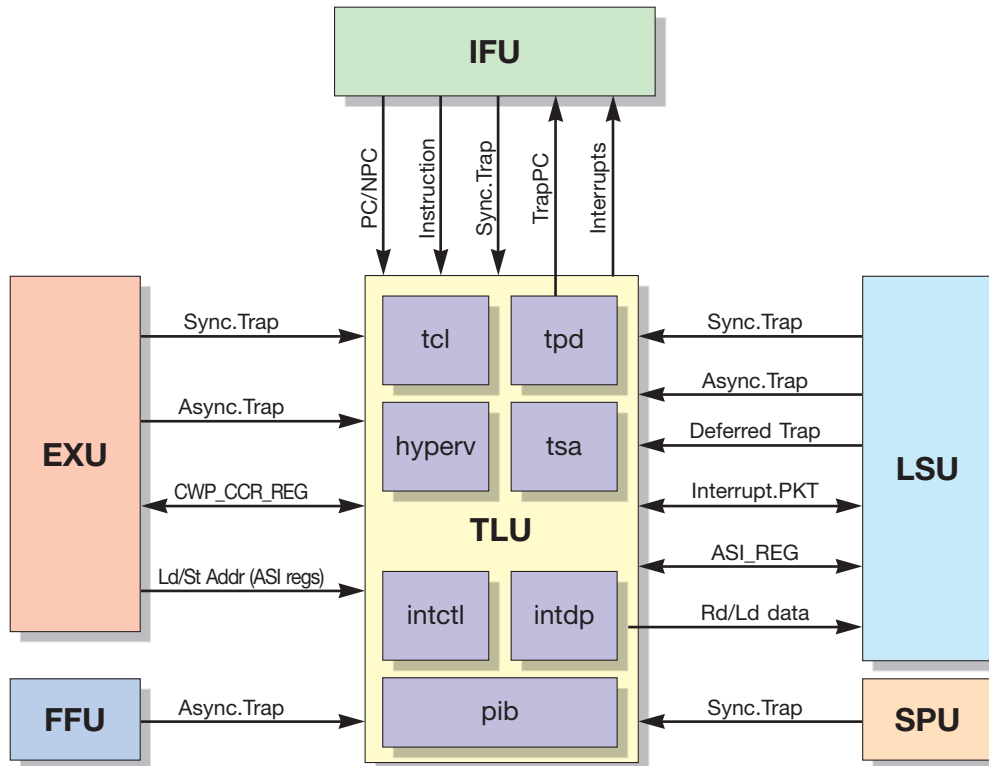

FIGURE 2-28 TLU Role With Respect to All Other Backlogs in a SPARC Core

The following list highlights the functionality of the TLU:

- Collects traps from all units in the SPARC core
- Detects some types of traps internal to the TLU
- Resolves the trap priority and generates the trap vector
- Sends flush-pipe to other SPARC units using a set of non-LSU traps.
- Maintains processors state registers
- Manages the trap stack
- Restores the processor state from the trap stack on done or retry instructions
- Implements an inter-thread interrupt delivery
- Receives and processes all types of interrupts
- Maintains tick, all tick-compares, and the SOFTINT related registers
- Generates timer interrupts and software interrupts (interrupt_level_n type)
- Maintains performance instrumentation counters (PIC)

2.10.1 Architecture Registers in the Trap Logic Unit

The following list highlights the architecture registers maintained by the trap logic unit (TLU). Only supervisor (SV) or hypervisor (HV) privileged code can access these registers.

1. Processor state and control registers
 - PSTATE (processor state) register
 - TL (trap level) register
 - GL (global register window level) register
 - PIL (processor interrupt level) register
 - TBA (trap base address) register
 - HPSTATE (Hypervisor processor state) register
 - HTBA (Hypervisor trap base address) register
 - HINTP (Hypervisor interrupt pending) register
 - HSTICK_CMPR_REG (Hypervisor system tick compare) register
2. Trap stack (six-deep)
 - TPC (trap PC) register
 - TNPC (trap next PC) register
 - TTYPE (trap type) register
 - TSTATE (trap state) register
 - HTSTATE (Hypervisor trap state) register
3. Ancillary state registers
 - TICK_REG (tick) register
 - STICK_REG (system tick) register
 - TICK_CMPR_REG (tick compare) register
 - STICK_CMPR_REG (system tick compare) register
 - SOFTINT_REG (software interrupt) register
 - SET_SOFTINT (set software interrupt register) register
 - CLEAR_SOFTINT (clear software interrupt register) register
 - PERF_CONTROL_REG (performance control) register
 - PERF_COUNTER (performance counter) register

4. ASI mapped registers
 - Scratch-pad registers (eight of them)
 - CPU and device mondo registers
 - Head and tail pointers of resumable and non-resumable error queue
 - CPU interrupt registers
 - Interrupt receive register
 - Incoming vector register
 - Interrupt dispatch registers (for cross-calls)

2.10.2 Trap Types

Traps can be generated from the user code, the supervisor code, or from the hypervisor code. A trap will be delivered to different trap handler levels for further processing, namely the supervisor level (SV level; otherwise known as the privileged level) or the hypervisor level (HV level). The way the traps are generated can help categorize a trap into either an asynchronous trap (asynchronous to the SPARC core pipeline operation) or a synchronous trap (synchronous to the SPARC core pipeline operation).

There are three defined categories of traps – precise trap, deferred trap, and disrupting trap. The following paragraphs briefly describe the nature of each category of trap.

1. Precise trap

A precise trap is induced by a particular instruction and occurs before any program-visible state has been changed by the trap-inducing instruction. When a precise trap occurs, several conditions must be true:

- The PC saved in TPC[TL] points to the instruction that induced the trap, and NPC saved in NTPC[TL] points to the instruction that was to be executed next.
- All instructions issued before the one that induced the trap must have completed their execution.
- Any instructions issued after the one that induced the trap remain unexecuted.

2. Deferred trap

A deferred trap is induced by a particular instruction. However, the trap may occur after the program-visible state has been changed by the execution of either the trap inducing instruction itself, or one or more other instructions.

If an instruction induces a deferred trap, and a precise trap occurs simultaneously, the deferred trap may not be deferred past the precise trap.

3. Disrupting trap

A disrupting trap is caused by a condition (for example, an interrupt), rather than directly caused by a particular instruction. When a disrupting trap has been serviced, the program execution resumes where it left off. A reset type of trap resumes execution at the unique reset address and it is not a disrupting trap.

Disrupting traps are controlled by a combination of the processor interrupt level (PIL) and the interrupt enable (IE) bit field of the processor state register (PSTATE). A disrupting trap condition is ignored when the interrupts are disabled (PSTATE.IE = 0) or the condition's interrupt level is lower than that specified in the PIL.

A disrupting trap may be due to either an interrupt request not directly related to a previously executed instruction, or to an exception related to a previously executed instruction. Interrupt requests may be either internal or external, and can be induced by the assertion of a signal not directly related to any particular processor or memory state.

A disrupting trap, related to an earlier instruction causing an exception, is similar to a deferred trap in that it occurs after instructions, follows the trap-inducing instruction, and modifies the processor or memory state. The difference is that the condition which caused the instruction to induce the trap may lead to unrecoverable errors, since the implantation may not preserve the necessary states.

Disrupting trap conditions should persist until the corresponding trap is taken.

TABLE 2-5 illustrates the type of traps supported by the OpenSPARC T1 processor.

TABLE 2-5 Supported OpenSPARC T1 Trap Types

Trap Type	Deferred	Disrupting	Precise
Asynchronous	None	None	Spill traps, FPU traps, DTLB parity error on loads, SPU-MA memory error return on load to SYNC reg
Synchronous	DTLB parity error on stores (precise to SW)	Interrupts and some error traps	All other traps

Asynchronous traps are taken opportunistically. They will be pending until the TLU can find a *trap bubble* in the SPARC core pipeline. A maximum of one asynchronous trap per thread can be pending at a time. When the other three threads are taking traps back-to-back, an asynchronous trap may wait a maximum three SPARC core clock cycles before the trap is taken.

2.10.3 Trap Flow

An asynchronous trap is normally associated with long latency instructions and saves/restores, so the occurrence of such a trap is not synchronous with the SPARC core pipeline operation. These traps are all precise traps in the OpenSPARC T1 processor. A trap bubble is identified in the W-stage when there is no valid instruction available, or the instruction there is taking a trap. Asynchronous traps will be taken at the W-stage when a trap bubble has been identified.

Disrupting traps are associated with certain particular conditions. The TLU collects them and forward them to the IFU. The IFU sends them down the pipeline as interrupts instead of sending instructions down. A trap bubble is thus guaranteed at the W-stage, and the trap will be taken.

FIGURE 2-29 illustrates the trap flow sequence.

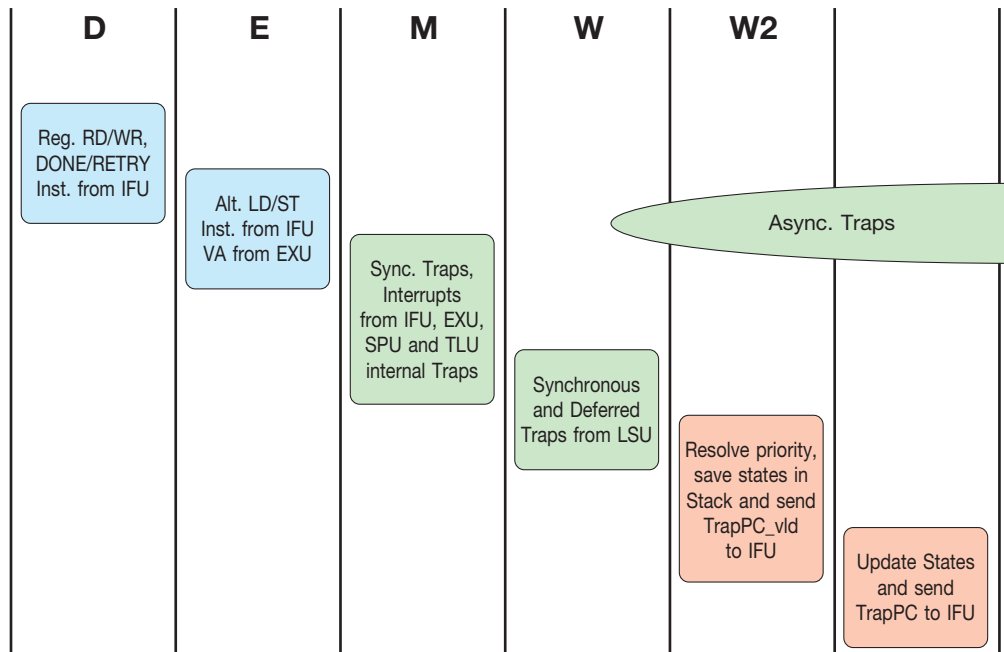

FIGURE 2-29 Trap Flow Sequence

All the traps from the IFU, EXU, SPU, LSU, and the TLU will be sorted through in order to resolve the priority first, and also to determine the following – trap type (TTYPE) and trap vector (redirect PC). After these are resolved, the trap base address (TBA) will be selected to travel down the pipeline for further execution.

FIGURE 2-30 illustrates the trap flow with respect to the hardware blocks.

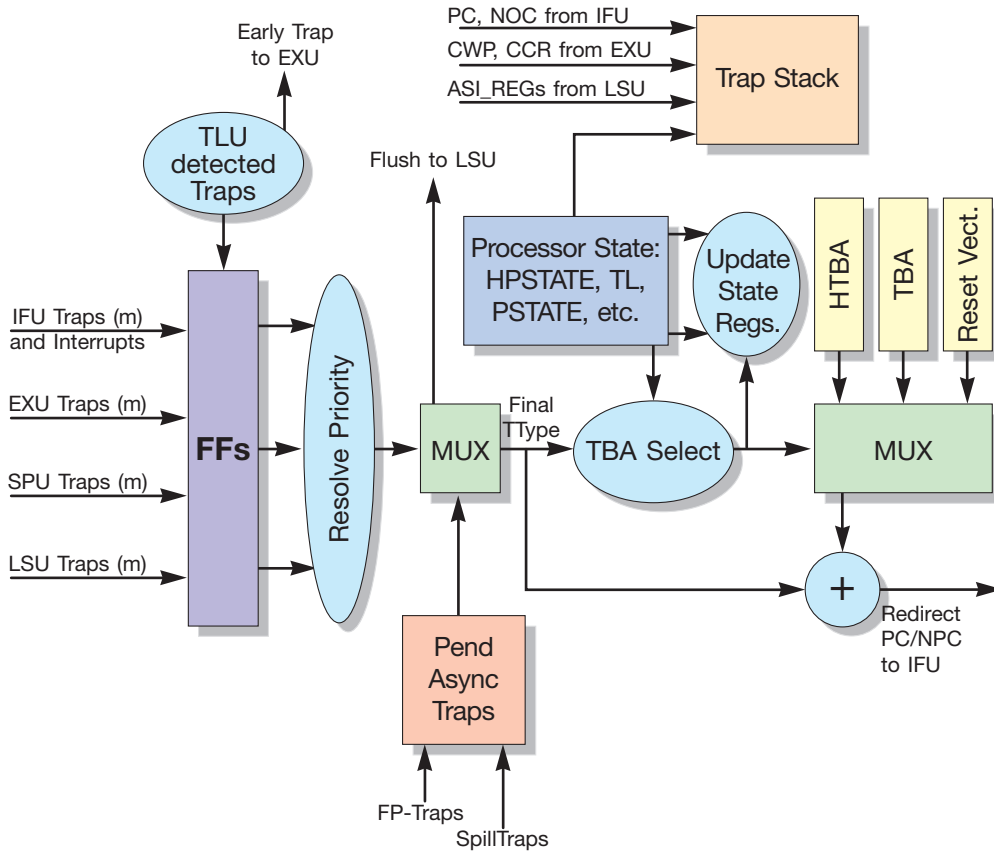

FIGURE 2-30 Trap Flow With Respect to the Hardware Blocks

2.10.4 Trap Program Counter Construction

The following list highlights the algorithm for constructing the trap program counter (TPC).

- Supervisor trap (SV trap)
Redirect PC \leq {TBA[47:15], (TL>0), TTYPE[8:0], 5'b000000}
- Hypervisor trap (HV trap)
Redirect PC \leq {TBA[47:14], TTYPE[8:0], 5'b000000}
- Traps in non-split mode
Redirect PC \leq {TBA[47:15], (TL>0), TTYPE[8:0], 5'b000000}
- Reset trap
Redirect PC \leq {RSTVAddr[47:8], (TL>0), RST_TYPE[2:0], 5'b000000}
 - RSTVAddr = 0xFFFFFFFFF0000000
- Done instruction
Redirect PC \leq TNPC[TL]
- Retry instruction
Redirect PC \leq TPC[TL]
Redirect NPC \leq TNPC[TL]

2.10.5 Interrupts

The software interrupts are delivered to each virtual core using the `interrupt_level_n` traps (0x41-0x4f) through the `SOFTINT_REG` register. I/O and CPU cross-call interrupts are delivered to each virtual core using the `interrupt_vector` trap (0x60).

`Interrupt_vector` traps for software interrupts have a corresponding 64-bit `ASI_SWVR_INTR_RECEIVE` register.

I/O devices and CPU cross-call interrupts contain a 6-bit identifier, which determines which interrupt vector (level) in the `ASI_SWVR_INTR_RECEIVE` register the interrupt will target. Each strand's `ASI_SWVR_INTR_RECEIVE` register can queue up to 64 outstanding interrupts, one for each interrupt vector. Interrupt vectors are implicitly prioritized with vector 63 being the highest priority and vector 0 being the lowest priority.

Each I/O interrupt source has a hard-wired interrupt number, which is used to index a table of interrupt vector information (`INT_MAN`) in the I/O bridge unit. Generally, each I/O interrupt source will be assigned a unique virtual core target and vector level. This association is defined by the software programming of the

interrupt vector and the VC_ID fields in the INT_MAN table of the I/O bridge (IOB). The software must maintain the association between the interrupt vector and the hardware interrupt number in order to index the appropriate entry in the INT_MAN and the INT_CTL tables.

2.10.6 Interrupt Flow

FIGURE 2-31 illustrates the flow of hardware interrupts and vector interrupts.

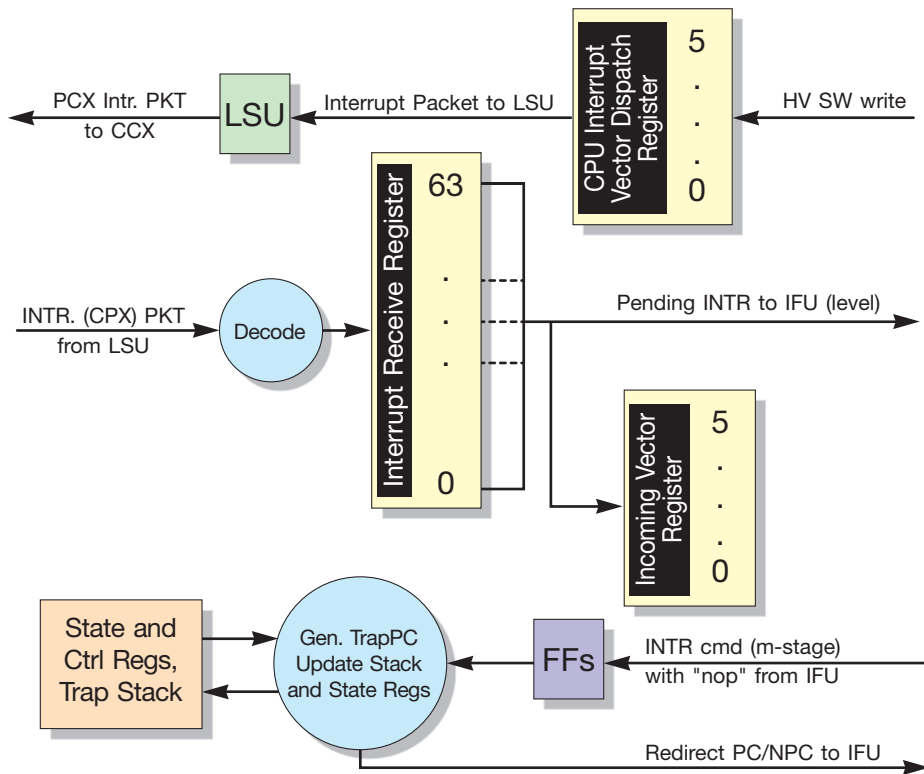

FIGURE 2-31 Flow of Hardware and Vector Interrupts

FIGURE 2-32 illustrates the flow of reset, idle, or resume interrupts.

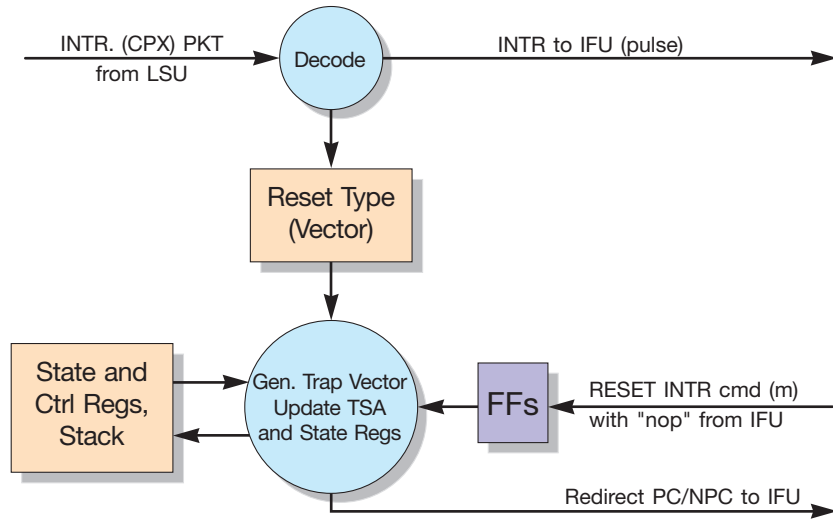

FIGURE 2-32 Flow of Reset or Idle or Resume Interrupts

FIGURE 2-33 illustrates the flow of software and timer interrupts.

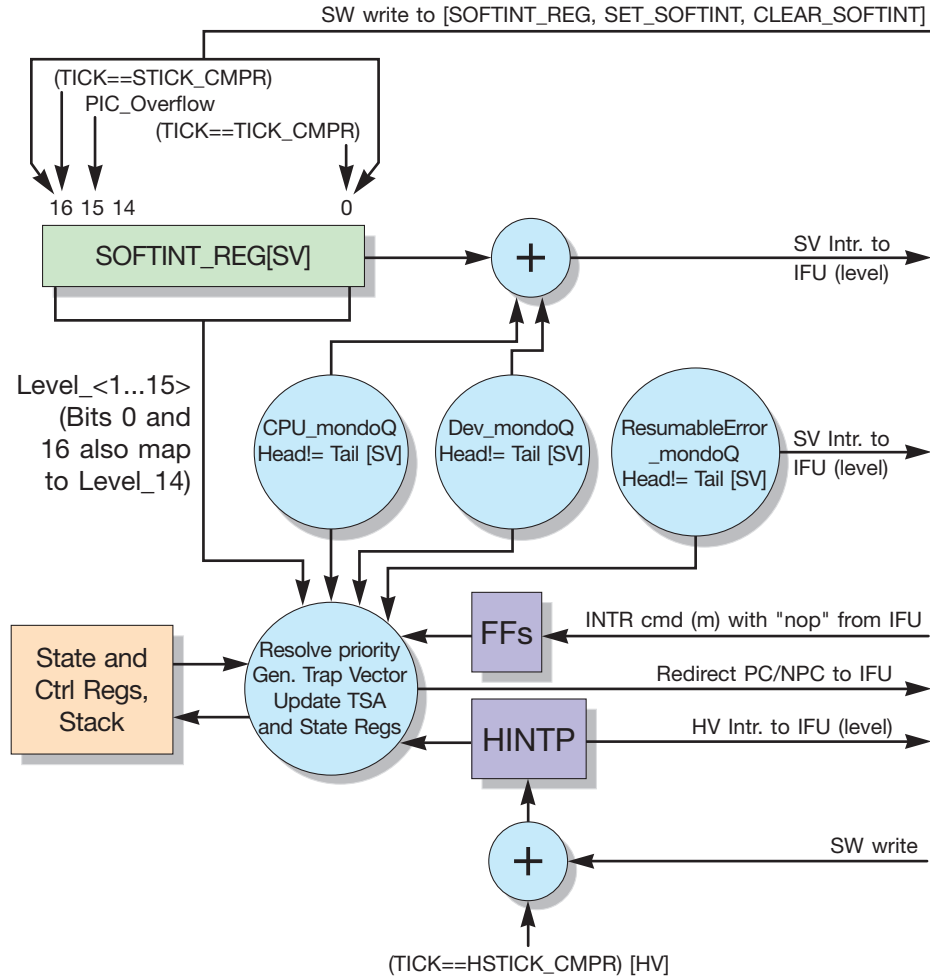

FIGURE 2-33 Flow of Software and Timer Interrupts

2.10.7 Interrupt Behavior and Interrupt Masking

The following list highlights the behavior and the masking of interrupts.

1. Hypervisor interrupts cannot be masked by the supervisor nor the user and can only be masked by the hypervisor by way of the PSTATE.IE bit. Such interrupts include hardware interrupts, HINTP, and so on.
2. Normal inter-core or inter-thread interrupts such as cross-calls can be sent by software writing to the CPU INT_VEC_DIS_REG register.
3. Special inter-core or inter-thread interrupts (such as reset, idle, or resume) can only be sent by software through the I/O bridge (IOB) by writing to the IOB INT_VEC_DIS_REG register.
4. Hypervisor will always suspend supervisor interrupts.
5. Some supervisor interrupts such as Mondo-Qs can only be masked by the PSTATE.IE bit.
6. Interrupts of *Interrupt_level_n*-type can only be masked by the PIL and the PSTATE.IE bit at the supervisor or user level.

2.10.8 Privilege Levels and States of a Thread

Split mode is referred to as the operating mode where hypervisor and supervisor modes are uniquely distinguished. Otherwise, the mode is referred to as non-split mode.

TABLE 2-6 illustrates the privilege levels and states of a thread.

TABLE 2-6 Privilege Levels and Thread States

		Split Mode			Non-Split Mode	
	Red	Hypervisor	Supervisor	User	Privileged	User
HPSTATE.enb	X	1	1	1	0	0
HPSTATE.red	1	0	0	0	0	0
HPSTATE.priv	1	1	0	0	X(1)	0
PSTATE.priv	1	X	1	0	1	0

2.10.9 Trap Modes Transition

FIGURE 2-34 illustrates the mode transitions among the different levels of traps.

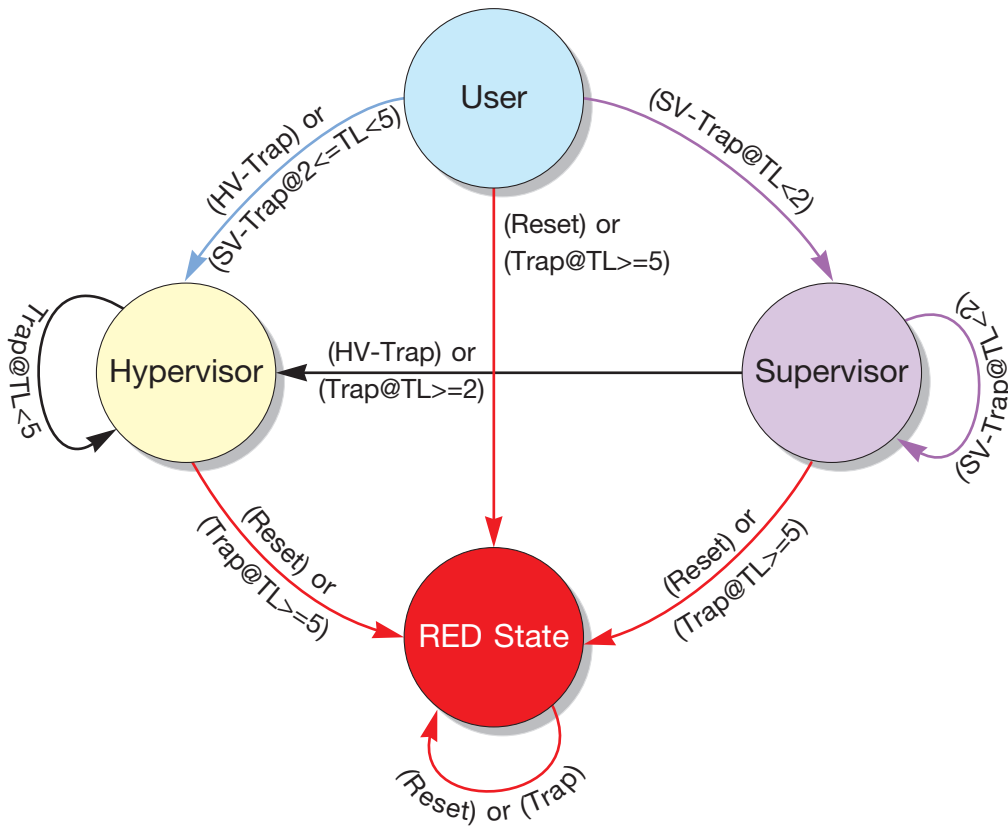

FIGURE 2-34 Trap Modes Transition

2.10.10 Thread States Transition

A thread can be in any one of these four states – RED (reset, error, debug), supervisor (SV), hypervisor (HV), or user. The privilege level is very different in each different states. [FIGURE 2-35](#) illustrates the state transition of a thread.

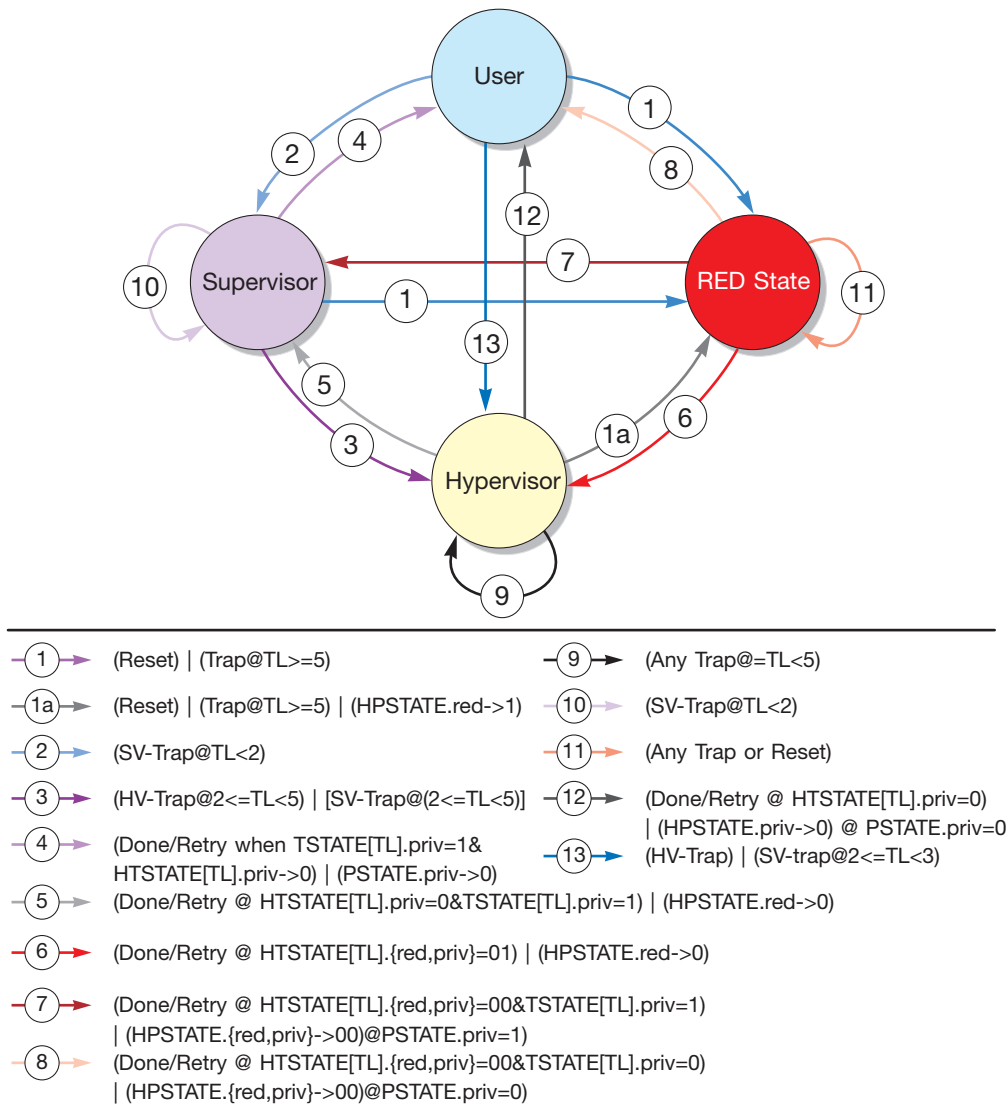

FIGURE 2-35 Thread State Transition

2.10.11 Content Construction for Processor State Registers

Processor state registers (PSRs) carry different content in different situations, such as, traps, interrupts, done instructions, or retry instructions. The following list highlights the register contents.

1. On traps or interrupts – save states in the trap stack and update them
 - a. Update trap level (TL) and global level (GL)
 - i. On normal traps or interrupts
$$TL = \min(TL+1, MAXTL)$$
$$GL = \min(GL+1, MAXGL) \text{ for hypervisor}$$
$$GL = \min(GL+1, 2) \text{ for supervisor}$$
 - ii. On power-on reset (POR) or warm reset
$$TL = MAXTL (=6)$$
$$GL = MAXGL (=3)$$
 - iii. On software write
For hypervisor:
$$TL \leq \min(wr\text{-}data[2:0], MAXTL) \text{ for hypervisor}$$
$$GL \leq \min(wr\text{-}data[3:0], MAXGL) \text{ for hypervisor}$$

For supervisor:
$$TL \leq \min(wr\text{-}data[2:0], 2) \text{ for supervisor}$$
$$GL \leq \min(wr\text{-}data[3:0], 2) \text{ for supervisor}$$
 - b. PC => TPC[TL]
 - c. NPC => TNPC[TL]
 - d. {ASI_REG, CCR_REG, GL, PSTATE} => TSTATE[TL]
 - e. Final_Trap_Type => TTYPE[TL]
 - f. HPSTATE => HTSTATE[TL]
 - g. Update HPSTATE[enb, red, priv, and so on] register
 - h. Update PSTATE[priv, ie, and so on] register

2. On done or retry instructions – restore states from trap stack
 - a. Update the trap level (TL) and the global level (GL)
TL <= TL -1
GL <= Restore from trap stack @TL and apply CAP
 - b. Restore all the registers including PC, NPC, HPSTATE, PSTATE, from the trap stack @[TL]
 - c. Send CWP and CCR register updates to the execution unit (EXU)
 - d. Send ASI register update to load store unit (LSU)
 - e. Send restored PC and NPC to the instruction fetch unit (IFU)
 - f. Decrement TL

2.10.12 Trap Stack

The OpenSPARC T1 processor supports a six deep trap stack for six trap levels. The trap stack has one read port and one write port (1R1W), and it stores the following registers:

- PC
- NPC
- HPSTATE (Note: The HPSTATE.enb bit is not saved)
- PSTATE
- GL
- CWP
- CCR
- ASI_REG
- TTYPE

Synchronization based on the HTSTATE.priv bit and the TSTATE.priv bit for the non-split mode is not enforced on software writes, but synchronized while restoring done and retry instructions.

Software writes in supervisor mode to the TSTATE.gl bit do not cap at two. The cap is applied while restoring done and retry instructions.

2.10.13 Trap (Tcc) Instructions

Traps number 0x0 to 0x7f are all SPARC V9 compliant. They can be used by user software or by privileged software. The trap will be delivered to the supervisor if $TL < MAXPTL(2)$. Otherwise, it will be delivered to the hypervisor.

Traps number 0x80 to 0xff can only be used by privileged software. These traps are always delivered to hypervisor. User software using trap number 0x80 to 0xff will result in an *illegal instruction* trap if the *condition code* evaluates to true. Otherwise, it is just a NOP.

The instruction decoding and condition code evaluation of Tcc instructions are done by the instruction fetch unit (IFU) and the seventh bit of the Trap# is checked by the TLU.

2.10.14 Trap Level 0 Trap for Hypervisor

Whenever the trap level (TL) changes from non-zero to zero, and if the HPSTATE.tlz bit is set to 1, and the thread is not at Hypervisor privilege level, then a precise trap level 0 (TLZ) trap will be delivered to the hypervisor on the next following instruction.

The trap level can be changed by the done or the retry instructions or a WRPR instruction to TL. The trap is taken on the instruction immediately following these instructions. The change could be stepping down the trap level, or changing the TL from >0 to 0. The HPSTATE.tlz bit will not be cleared by the hardware when a trap is taken so the TLZ trap (tlz-trap) handler has to clear this bit before returning in order to avoid the infinite tlz-trap loop.

2.10.15 Performance Control Register and Performance Instrumentation Counter

Each thread has a privileged performance control register (PCR). Non-privileged accesses to this register causes a *privileged_opcode* trap.

Each thread has a performance instrumentation counter (PIC) register. The access privileged is controlled by the setting the PERF_CONTROL_REG.PRIV bit. When PERF_CONTROL_REG.PRIV=1, non-privileged accesses to this register cause a *privileged_action* trap.

FIGURE 2-36 highlights the layout of PCR and PIC.

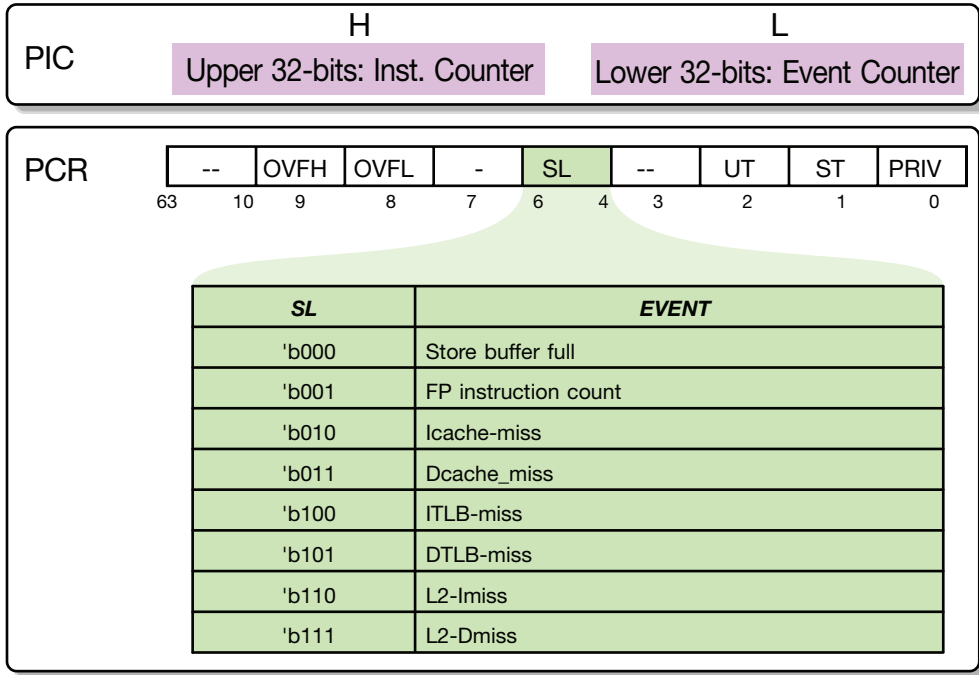

FIGURE 2-36 PCR and PIC Layout

If the PCR.OVFH bit is set to 1, the PIC.H has overflowed and the next event will cause a disrupting trap that appears to be precise to the instruction following the event.

If the PCR.OVFL bit is set to 1, the PIC.L has overflowed and next event will cause a disrupting trap that appears to be precise to the instruction following the event.

If the PCR.UT bit is set to 1, it counts events in user mode. Otherwise, it will ignore user mode events.

If the PCR.ST bit is set to 1 and HPSTATE.ENB is also set to 1, it counts events in supervisor mode. Otherwise, it will ignore supervisor mode events.

If the PCR.ST bit is set to 1 and HPSTATE.ENB is also set to 0, it counts events in hypervisor mode. Otherwise, it will ignore hypervisor mode events.

If the PCR.PRIV bit is set to 1, it prevents user code access to the PIC counter. Otherwise, it allows the user code to access the PIC counter.

The PIC.H bits form the instruction counter. Trapped or canceled instructions will not be counted. The Tcc instructions will be counted even if some other trap is taken on them.

The PIC.L bits form the event counter. The TLU includes only the counter control logic, while the other functional units in the SPARC core provide the logic to signal any event. An event counter overflow will generate a disrupting trap, while a performance counter overflow will generate a disrupting but precise trap (of a type level_15 interrupt) on the next following instruction and set the PCR.OVFH or the PCR.OVFL bits and bit-15 of the SOFTINT_REG register.

Software writes to the PCR that set one of the overflow bits (OVFH, OVFL) will also cause a disrupting but precise trap on the instruction following the next incrementing event.

CPU-Cache Crossbar

This chapter contains the following topics:

- [Section 3.1, “Functional Description” on page 3-1](#)
- [Section 3.2, “CCX I/O List” on page 3-9](#)
- [Section 3.3, “CCX Timing Diagrams” on page 3-13](#)
- [Section 3.4, “PCX Internal Blocks Functional Description” on page 3-17](#)
- [Section 3.5, “CPX Internal Blocks Functional Description” on page 3-20](#)

3.1 Functional Description

3.1.1 CPU-Cache Crossbar Overview

The CPU-cache crossbar (CCX) manages the communication among the eight CPU cores, the four L2-cache banks, the I/O bridge, and the floating-point unit (FPU). These functional units communicate with each by sending packets, and the CCX arbitrates the packet delivery.

Each SPARC CPU core can send a packet to any one of the L2-cache banks, the I/O bridge, or the FPU. Conversely, packets can also be sent in the reverse direction, where any of the four L2-cache banks, the I/O bridge, or the FPU can send a packet to any one of the eight CPU cores.

[FIGURE 3-1](#) shows that each of the eight SPARC CPU cores can communicate with each of the four L2-cache banks, the I/O bridge, and the FPU. The cache-processor crossbar (CPX) and the processor-cache crossbar (PCX) packet formats are described in [Section 3.1.5, “CPX and PCX Packet Formats” on page 3-5](#).

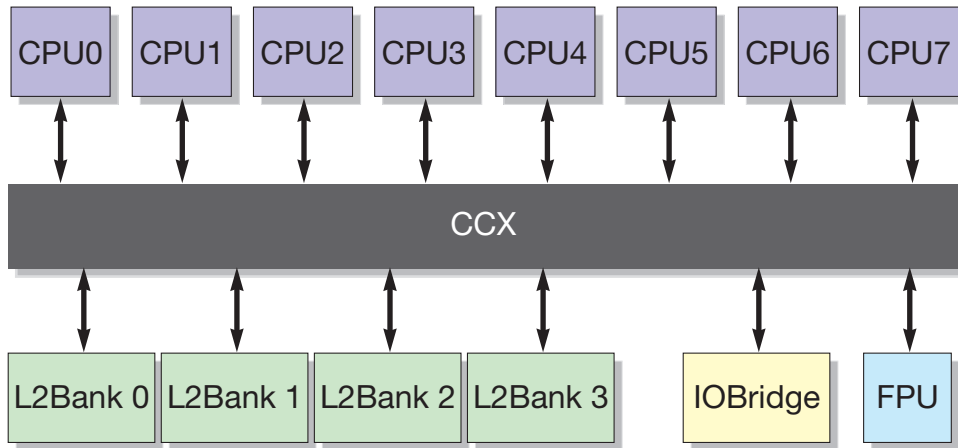

FIGURE 3-1 CPU Cache-Crossbar (CCX) Interface

3.1.2 CCX Packet Delivery

The CCX consists of two main blocks – processor-cache crossbar (PCX) and the cache-processor crossbar (CPX). The PCX block manages the communication from any of the eight CPUs (source) to any of the four L2-cache banks, I/O bridge, or FPU (destination). The CPX manages communication from any of the four L2-cache banks, I/O bridge, or FPU (source), to any of the eight CPUs (destination). [FIGURE 3-2](#) illustrates the PCX interface and [FIGURE 3-3](#) illustrates the CPX interface.

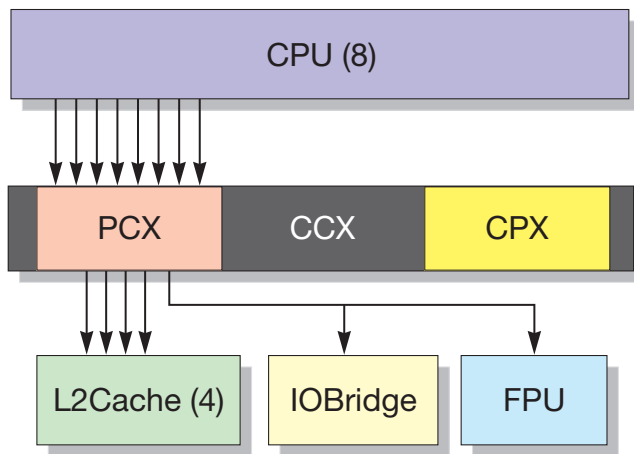

FIGURE 3-2 Processor Cache-Crossbar (PCX) Interface

When multiple sources send a packet to the same destination, the CCX buffers each packet and arbitrates its delivery to the destination. The CCX does not modify or process any packet.

In one cycle, only one packet can be delivered to a particular destination. The CCX handles two types of communication requests. The first type of requests contain one packet and it is delivered in one cycle. The second type of request contains two packets, and these two packets are delivered in two cycles.

The total number of cycles required for a packet to travel from the source to the destination may be more than the number of cycles required to deliver a packet. This issue occurs when the PCX (or the CCX) uses more than one cycle to deliver the packet. The PCX (or the CCX) uses more than one cycle to deliver a particular packet if multiple sources can send packets for the same destination.

3.1.3 Processor-Cache Crossbar Packet Delivery

The processor-cache crossbar (PCX) accepts packets from a source (any of eight SPARC CPU cores) and delivers the packet to its destination (any one of the four L2-cache banks, the I/O bridge, or the FPU).

A source sends a packet and a destination ID to the PCX. These packets are sent on a 124-bit wide bus. Out of the 124 bits, 40 bits are used for address, 64 bits for data, and rest of the bits are used for control. The destination ID is sent on a separate 5-bit bus. Each source connects with its own separate bus to the PCX. Therefore, there are eight buses that connect from the CPUs to the PCX.

The PCX connects to each destination by way of a separate bus. However, the FPU and I/O bridge share the same bus. Therefore, there are five buses that connect the PCX to the six destinations. The PCX does not perform any packet processing and therefore the bus width from the PCX to each destination is 124-bits wide, which is identical to the PCX packet width. [FIGURE 3-2](#) illustrates this PCX interface.

Since both the FPU and the I/O bridge share a destination ID, the packets intended for each get routed to both. The FPU and I/O bridge each decode the packet to decide whether to consume or discard the packet.

A source can send at most two single-packet requests or one two-packet request to a particular destination. There is a *2 deep* queue inside the PCX for each source-destination pair that holds the packet. The PCX sends a grant to the source after dispatching a packet to its destination. Each source uses this handshake signal to monitor the queue full condition.

The L2-caches and the I/O bridge can process a limited number of packets. When a destination reaches its limit, it sends a stall signal to the PCX. This stall signal prevents the PCX from sending the grant to a source (CPU core). The FPU, however, cannot stall the PCX.

3.1.4 Cache-Processor Crossbar Packet Delivery

The cache-processor crossbar (CPX) accepts packets from a source (which can be one of the four L2-cache banks, the I/O bridge, or the FPU) and delivers the packet to its destination (one any of eight SPARC CPU cores).

A source sends a packet and a destination ID to the CPX. The packets are sent on a 145-bit wide bus. Out of the 145 bits, the 128 bits is used for data and the rest of the bits are used for control.

The destination ID is sent on a separate 8-bit bus. Each source connects with the CPX on its own separate bus. Therefore, there are six buses that connect from the four L2-caches, the I/O bridge, and the FPU to the CPX. The CPX connects by way of a separate bus to each destination. Therefore, there are eight buses from the CPX that connect it to the six destinations. The CPX does not perform any packet processing, so the bus width from the CPX to each destination is 145-bits wide, which is identical to the bus width from the source to the CPX. [FIGURE 3-3](#) illustrates the CPX interface.

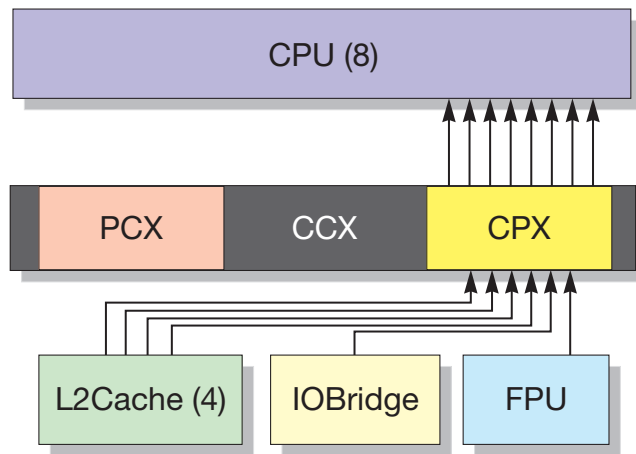

FIGURE 3-3 Cache-Processor Crossbar (CPX) Interface

A source can send at most two single-packet requests, or one two-packet request, to a particular destination. There is a 2 *deep* queue inside the CPX for each source-destination pair that holds the packet. The CPX sends a grant to the source after dispatching a packet to its destination. Each source uses this handshake signal to monitor the queue full condition.

Unlike the PCX, the CPX does *not* receive a stall from any of its destinations, as each CPU has an efficient mechanism to drain the buffer that stores the incoming packets.

3.1.5 CPX and PCX Packet Formats

TABLE 3-1 and TABLE 3-2 define the CPX packet format, and TABLE 3-3 and TABLE 3-4 define the PCX packet format.

Note – For the next four packet format tables, the table entries are defined as follows:

- x – Not used or don't care
- V – Valid
- rs – Source register
- rd – Destination register
- T – Thread ID
- FD – Forwarded data
- src – Source
- tar – Target

TABLE 3-1 CPX Packet Format – Part 1

Pkt	bits	No.	Load	ISfill (1) L2,IJOB	ISfill (2) L2	Strm Load	Evict Inv
Valid	144	1	V	V	V	V	V
Rtntyp	143:140	4	0000	0001	0001	0010	0011
L2 miss	139	1	V	V	0	V	x
ERR	138:137	2	V	V	V	V	x
NC	136	1	V	V	V	V	V
Shared bit	135	1	T	T	T	T	x
Shared bit	134	1	T	T	T	T	x
Shared bit	133	1	WV	WV,0	WV	WV	x
Shared bit	132	1	W	W,x	W	W	x
Shared bit	131	1	W	W,x	W	W	x
Shared bit	130	1	0	0, F4B	0	A	x
Shared bit	129	1	atomic	0	1	B	x
Reserved	128	1	PFL	0	0	0	0
Data	127:0	128	V	V	V	V	{INV1 +6(pa) +112(inv)}

TABLE 3-2 CPX Packet Format – Part 2

Pkt	bits	No.	Store Ack	Strm Store Ack	Int	FP	Fwd req	Fwd Reply	Error
Valid	144	1	V	V	V	V	V	V	V
Rtntyp	143:140	4	0100	0101 0110	0111	1000 1001	1010	1011	1100
L2 miss	139	1	x	x	x	x	x	x	x
ERR	138:137	2	x	x	x	x	x	V	V
NC	136	1	V	V	flush	V	R/!W	R/!W	x
Shared bit	135	1	T	T	x	T	x	x	0
Shared bit	134	1	T	T	x	T	x	x	0
Shared bit	133	1	x	x	x	x	src	tar	x
Shared bit	132	1	x	x	x	x	src	tar	x
Shared bit	131	1	x	x	x	x	src	tar	x
Shared bit	130	1	x/R	A	x	x	SASI	x	x
Shared bit	129	1	atomic	x	x	x	x	x	x
Reserved	128	1	x/R	0	0	0 0	0	0	0
Data	127:0	128	{INV2 +3(cpu) +6(pa) +112(inv)}	{INV3 +3(cpu) +6(pa) +112(inv)}	V!	V*	FD	{64(x) + Data}	x

TABLE 3-3 PCX Packet Format – Part 1

Pkt	Bits	No.	Load	Ifill Req	ST	CAS(1)	CAS(2)
Valid	123	1	V	V	V	V	V
Rqtyp	122:118	5	00000	10000	00001	00010	00011
NC	117	1	V	V	V	'1'	'1'
Cpu_idfs	116:114	3	V	V	V	V	V
Thread_id	113:112	2	V	V	V	V	V
Invalidate	111	1	V	V	0	0	0
Prefetch	110	1	V	0	BST	0	0
Block init store/ Displacement flush	109	1	DF	0	BIS/BST	0	0
Rep_L1_way	108:107	2	V	V	P	V	x
Size	106:104	3	V	x	V	V	V
Address	103:64	40	V	V#	V	V	V
Data	63:0	64	x	x	V	Vrs2	Vrd

TABLE 3-4 PCX Packet Format – Part 2

Pkt	Bits	No.	SWP Ldstb	Stream loads	Stream Store	Int	FP (1)	FP (2)	Fwd req	Fwd reply
Valid	123	1	V	V	V	V	V	V	V	V
Rqtyp	122:118	5	00110	00100	00101	01001	01010	01011	01100	01101 01110
NC	117	1	'1'	'1'	V	Br	x	x	R/!W	R/!W
Cpu_id	116:114	3	V	V	V	V	V	V	src	tar
Thread_id	113:112	2	V	V	V	V	V	V	000	x
Invalidate	111	1	0	0	0	0	x	x	0	0
Prefetch	110	1	0	0	0	0	x	x	0	0
Block init store/ Displacement flush	109	1	0	0	0	0	x	x	0	0
Rep_L1_way	108:107	2	V	V	A,x	x	x	x	x	x
Size	106:104	3	V	A,B,x	V	x	x	x	011	ERR
Address	103:64	40	V	V	V	x	V*	V*	V	x
Data	63:0	64	Vrs2	x	V	V!	RS2	RS1	V/x	V/x

3.2 CCX I/O List

TABLE 3-5 lists the CCX I/O signals.

TABLE 3-5 CCX I/O Signal List

Signal Name	I/O	Source/Destination	Description
adbginit_l	In		Asynchronous reset
ccx_scanin0	In	DFT	Scan in 0
ccx_scanin1	In	DFT	Scan in 1
clk_ccx_cken	In	CTU	
cmp_arst_l	In	CTU	Asynchronous reset
cmp_grst_l	In	CTU	Synchronous reset
ctu_tst_macrotest	In	CTU	
ctu_tst_pre_grst_l	In	CTU	
ctu_tst_scan_disable	In	CTU	
ctu_tst_scanmode	In	CTU	
ctu_tst_short_chain	In	CTU	
fp_cpx_data_ca[144:0]	In	FPU	FPU CPX data
fp_cpx_req_cq[7:0]	In	FPU	FPU CPX request
gclk[1:0]	In	CTU	Clock
gdbginit_l	In	CTU	Synchronous reset
global_shift_enable	In	CTU	
iob_cpx_data_ca[144:0]	In	IOB	IOB CPX data
iob_cpx_req_cq[7:0]	In	IOB	IOB CPX request
sctag0_cpx_atom_cq	In	L2-Bank0	Atomic packet
sctag0_cpx_data_ca[144:0]	In	L2-Bank0	L2 CPX data
sctag0_cpx_req_cq[7:0]	In	L2-Bank0	L2 CPX request
sctag0_pcx_stall_pq	In	L2-Bank0	PCX Stall
sctag1_cpx_atom_cq	In	L2-Bank1	Atomic packet
sctag1_cpx_data_ca[144:0]	In	L2-Bank1	L2 CPX data
sctag1_cpx_req_cq[7:0]	In	L2-Bank1	L2 CPX request

TABLE 3-5 CCX I/O Signal List (*Continued*)

Signal Name	I/O	Source/Destination	Description
sctag1_pcx_stall_pq	In	L2-Bank1	PCX stall
sctag2_cpx_atom_cq	In	L2-Bank2	Atomic packet
sctag2_cpx_data_ca[144:0]	In	L2-Bank2	L2 CPX data
sctag2_cpx_req_cq[7:0]	In	L2-Bank2	L2 CPX request
sctag2_pcx_stall_pq	In	L2-Bank2	PCX stall
sctag3_cpx_atom_cq	In	L2-Bank3	Atomic packet
sctag3_cpx_data_ca[144:0]	In	L2-Bank3	L2 CPX data
sctag3_cpx_req_cq[7:0]	In	L2-Bank3	L2 CPX request
sctag3_pcx_stall_pq	In	L2-Bank3	PCX stall
spc0_pcx_atom_pq	In	sparc0	Atomic packet
spc0_pcx_data_pa[123:0]	In	sparc0	SPARC PCX data/address
spc0_pcx_req_pq[4:0]	In	sparc0	SPARC PCX request
spc1_pcx_atom_pq	In	sparc1	Atomic packet
spc1_pcx_data_pa[123:0]	In	sparc1	SPARC PCX data/address
spc1_pcx_req_pq[4:0]	In	sparc1	SPARC PCX request
spc2_pcx_atom_pq	In	sparc2	Atomic packet
spc2_pcx_data_pa[123:0]	In	sparc2	SPARC PCX data/address
spc2_pcx_req_pq[4:0]	In	sparc2	SPARC PCX request
spc3_pcx_atom_pq	In	sparc3	Atomic packet
spc3_pcx_data_pa[123:0]	In	sparc3	SPARC PCX data/address
spc3_pcx_req_pq[4:0]	In	sparc3	SPARC PCX request
spc4_pcx_atom_pq	In	sparc4	Atomic packet
spc4_pcx_data_pa[123:0]	In	sparc4	SPARC PCX data/address
spc4_pcx_req_pq[4:0]	In	sparc4	SPARC PCX request
spc5_pcx_atom_pq	In	sparc5	Atomic packet
spc5_pcx_data_pa[123:0]	In	sparc5	SPARC PCX data/address
spc5_pcx_req_pq[4:0]	In	sparc5	SPARC PCX request
spc6_pcx_atom_pq	In	sparc6	Atomic packet
spc6_pcx_data_pa[123:0]	In	sparc6	SPARC PCX data/address
spc6_pcx_req_pq[4:0]	In	sparc6	SPARC PCX request

TABLE 3-5 CCX I/O Signal List (*Continued*)

Signal Name	I/O	Source/Destination	Description
spc7_pcx_atom_pq	In	sparc7	Atomic racket
spc7_pcx_data_pa[123:0]	In	sparc7	SPARC PCX data/address
spc7_pcx_req_pq[4:0]	In	sparc7	SPARC PCX request
iob_pcx_stall_pq	In		IOB PCX stall
ccx_scanout0	Out	DFT	Scan out 0
ccx_scanout1	Out	DFT	Scan out 1
cp_x_iob_grant_cx2[7:0]	Out	IOB	CPX grant
cp_x_sctag0_grant_cx[7:0]	Out	L2-Bank0	CPX grant
cp_x_sctag1_grant_cx[7:0]	Out	L2-Bank1	CPX grant
cp_x_sctag2_grant_cx[7:0]	Out	L2-Bank2	CPX grant
cp_x_sctag3_grant_cx[7:0]	Out	L2-Bank3	CPX grant
cp_x_spc0_data_cx2[144:0]	Out	sparc0	CPX SPARC data
cp_x_spc0_data_rdy_cx2	Out	sparc0	CPX data ready
cp_x_spc1_data_cx2[144:0]	Out	sparc1	CPX SPARC data
cp_x_spc1_data_rdy_cx2	Out	sparc1	CPX data ready
cp_x_spc2_data_cx2[144:0]	Out	sparc2	CPX SPARC data
cp_x_spc2_data_rdy_cx2	Out	sparc2	CPX data ready
cp_x_spc3_data_cx2[144:0]	Out	sparc3	CPX SPARC data
cp_x_spc3_data_rdy_cx2	Out	sparc3	CPX data ready
cp_x_spc4_data_cx2[144:0]	Out	sparc4	CPX SPARC data
cp_x_spc4_data_rdy_cx2	Out	sparc4	CPX data ready
cp_x_spc5_data_cx2[144:0]	Out	sparc5	CPX SPARC data
cp_x_spc5_data_rdy_cx2	Out	sparc5	CPX data ready
cp_x_spc6_data_cx2[144:0]	Out	sparc6	CPX SPARC data
cp_x_spc6_data_rdy_cx2	Out	sparc6	CPX data ready
cp_x_spc7_data_cx2[144:0]	Out	sparc7	CPX SPARC data
cp_x_spc7_data_rdy_cx2	Out	sparc7	CPX data ready
pcx_fp_data_px2[123:0]	Out	FPU	PCX data
pcx_fp_data_rdy_px2	Out	FPU	PCX data ready
pcx_iob_data_px2[123:0]	Out	IOB	PCX data

TABLE 3-5 CCX I/O Signal List (*Continued*)

Signal Name	I/O	Source/Destination	Description
pcx_iob_data_rdy_px2	Out	IOB	PCX data ready
pcx_sctag0_atm_px1	Out	L2-Bank0	PCX atomic packet
pcx_sctag0_data_px2[123:0]	Out	L2-Bank0	PCX data
pcx_sctag0_data_rdy_px1	Out	L2-Bank0	PCX data ready
pcx_sctag1_atm_px1	Out	L2-Bank1	PCX atomic packet
pcx_sctag1_data_px2[123:0]	Out	L2-Bank1	PCX data
pcx_sctag1_data_rdy_px1	Out	L2-Bank1	PCX data ready
pcx_sctag2_atm_px1	Out	L2-Bank2	PCX atomic packet
pcx_sctag2_data_px2[123:0]	Out	L2-Bank2	PCX data
pcx_sctag2_data_rdy_px1	Out	L2-Bank2	PCX data ready
pcx_sctag3_atm_px1	Out	L2-Bank3	PCX atomic packet
pcx_sctag3_data_px2[123:0]	Out	L2-Bank3	PCX data
pcx_sctag3_data_rdy_px1	Out	L2-Bank3	PCX data ready
pcx_spc0_grant_px[4:0]	Out	sparc0	PCX grant to SPARC
pcx_spc1_grant_px[4:0]	Out	sparc1	PCX grant to SPARC
pcx_spc2_grant_px[4:0]	Out	sparc2	PCX grant to SPARC
pcx_spc3_grant_px[4:0]	Out	sparc3	PCX grant to SPARC
pcx_spc4_grant_px[4:0]	Out	sparc4	PCX grant to SPARC
pcx_spc5_grant_px[4:0]	Out	sparc5	PCX grant to SPARC
pcx_spc6_grant_px[4:0]	Out	sparc6	PCX grant to SPARC
pcx_spc7_grant_px[4:0]	Out	sparc7	PCX grant to SPARC
rclk	Out	CCX	Clock

3.3 CCX Timing Diagrams

FIGURE 3-4 shows the timing diagram for processing a single packet request.

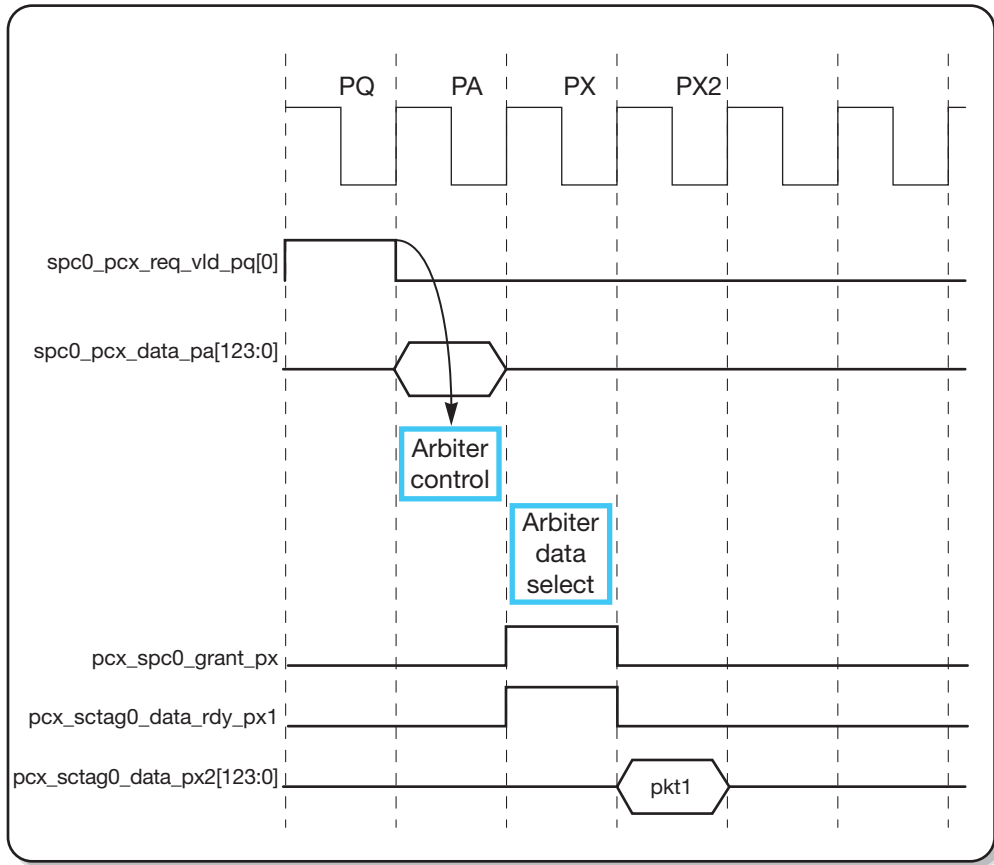

FIGURE 3-4 PCX Packet Transfer Timing – One Packet Request

CPU0 signals the PCX that it is sending a packet in cycle PQ. CPU0 then sends a packet in cycle PA. ARB0 looks at all pending requests and issues a grant to CPU0 in cycle PX. ARB0 sends a data ready signal to the L2-cache Bank0 in cycle PX. ARB0 sends the packet to the L2-cache Bank0 in cycle PX2.

FIGURE 3-5 shows timing diagram for processing a two-packet request.

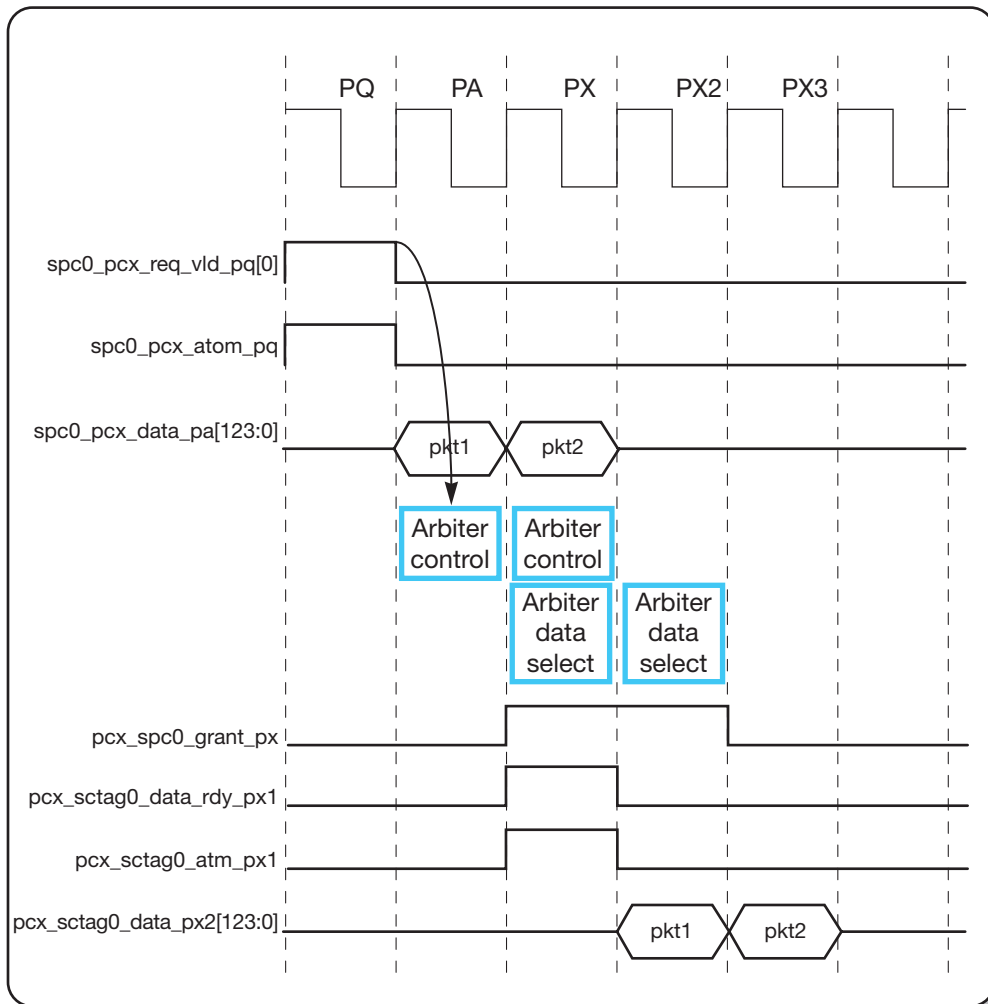

FIGURE 3-5 PCX Packet Transfer Timing – Two-Packet Request

CPU0 signals the PCX that it is sending a packet in cycle PQ. CPU0 also asserts `spc0_pcx_atom_pq`, which tells the PCX that CPU0 is sending a two-packet request. The PCX handles all two-packet requests atomically. CPU0 sends the first packet in cycle PA and the second packet in cycle PX. ARB0 looks at all pending requests and issues a grant to CPU0 in cycle PX. The grant is asserted for two cycles. The PCX also asserts `pcx_sctag0_atm_px1` in cycle PX, which tells the L2-cache Bank0 that the PCX is sending a two-packet request. ARB0 sends a data ready signal to the L2-cache Bank0 in cycle PX. ARB0 sends the two packets to the L2-cache Bank0 in cycles PX2 and PX3.

Note – FIGURE 3-4 and FIGURE 3-5 represent the best case scenario when there are no pending requests.

The timing for CPX transfers is similar to PCX transfers with the following difference—the data ready signal from the CPX is delayed by one cycle before sending the packet to its destination. FIGURE 3-6 and FIGURE 3-7 shows the CPX packet transfer timing diagrams.

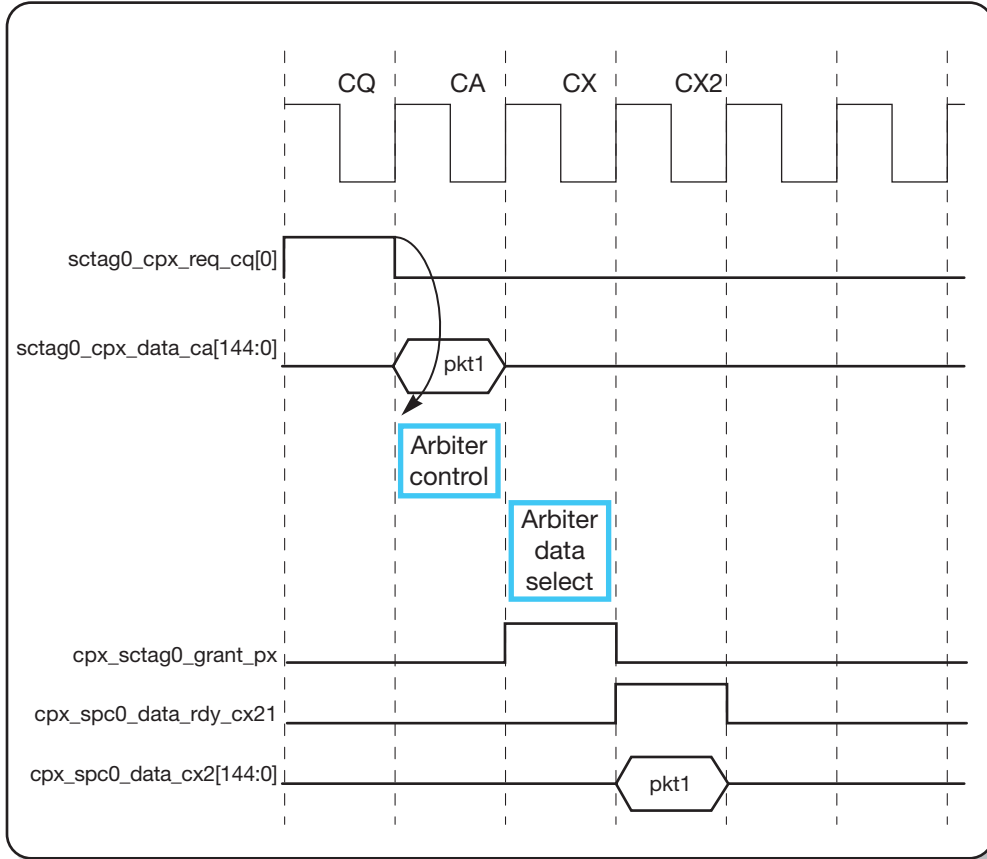

FIGURE 3-6 CPX Packet Transfer Timing Diagram – One Packet Request

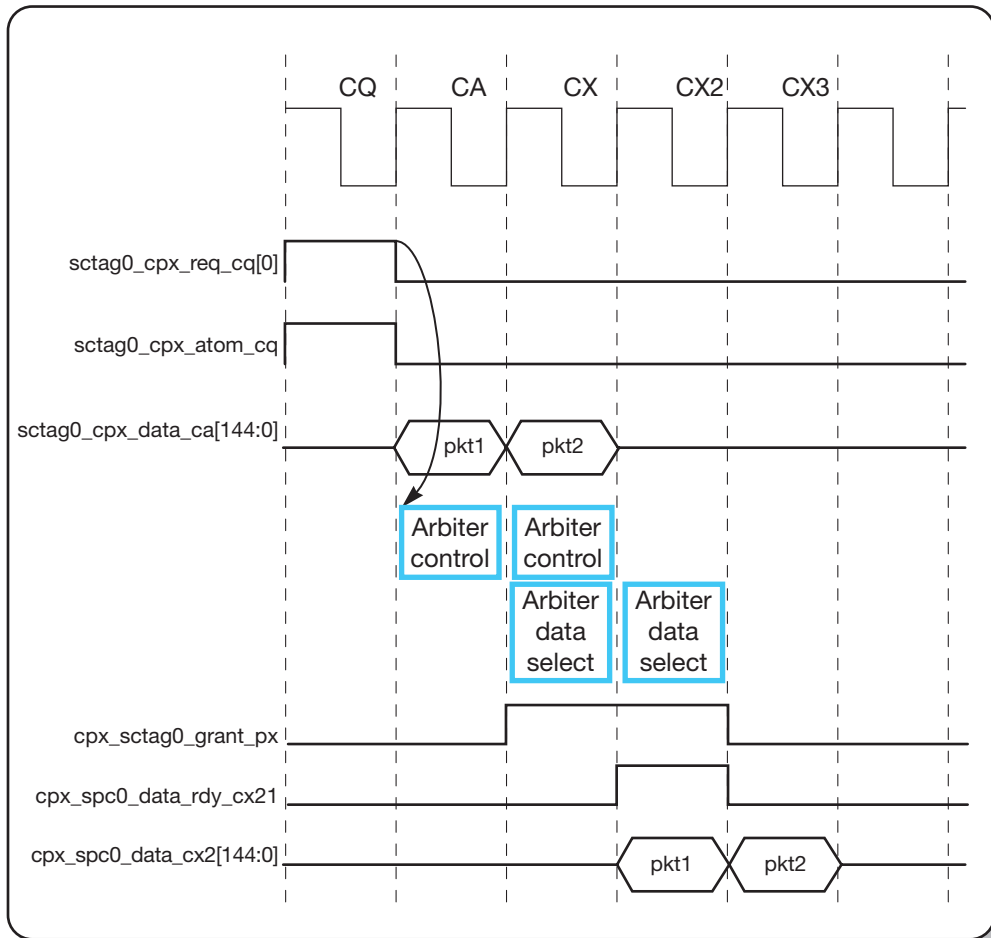

FIGURE 3-7 CPX Packet Transfer Timing Diagram – Two Packet Request

3.4 PCX Internal Blocks Functional Description

3.4.1 PCX Overview

The PCX contains five identical arbiter modules—one for each destination. An arbiter stores the packets from the sources for one particular destination. The PCX then arbitrates and dispatches packets to that destination. [FIGURE 3-8](#) shows a block diagram of the PCX arbitration.

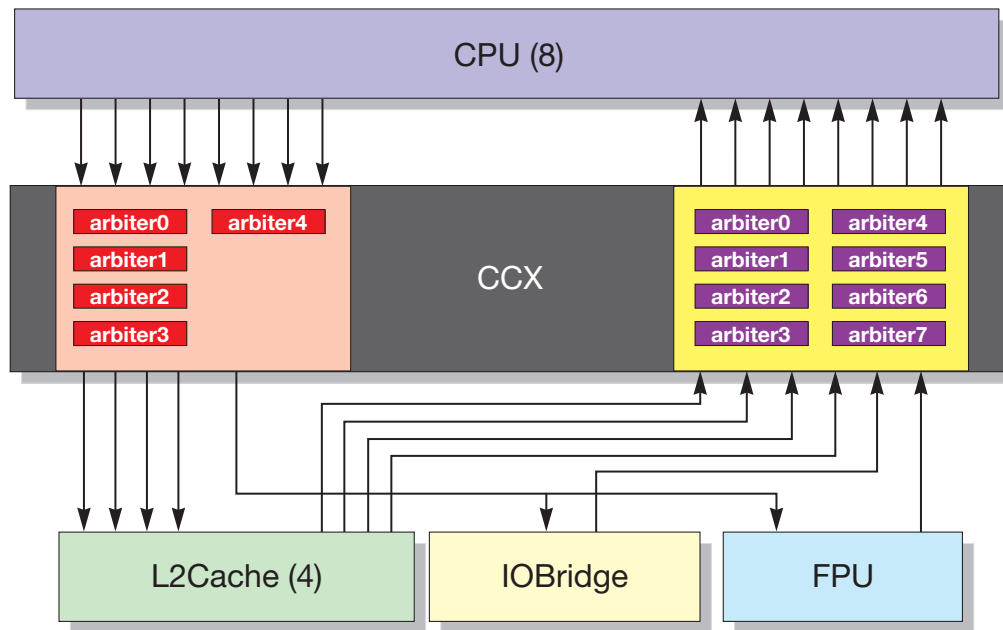

FIGURE 3-8 PCX and CPX Internal Blocks

3.4.2 PCX Arbiter Data Flow

The PCX contains five identical arbiter modules. While data flows similarly inside other arbiters, this section will describe the data flow inside one of the arbiters (ARB0). There is a 124-bit wide bus from each SPARC CPU core that extends out to the five arbiters (one bus for each arbiter corresponding to a destination).

ARB0 can receive packets from any of the eight CPUs for the L2-cache Bank0, and it stores packets from each CPU in a separate queue. Therefore, ARB0 contains eight queues. Each queue is a two entry deep FIFO, and each entry can hold one packet. A packet is 124-bits wide and it contains the address, the data, and the control bits. ARB0 delivers packets to the L2-cache Bank0 on a 124-bit wide bus. FIGURE 3-9 shows this data flow.

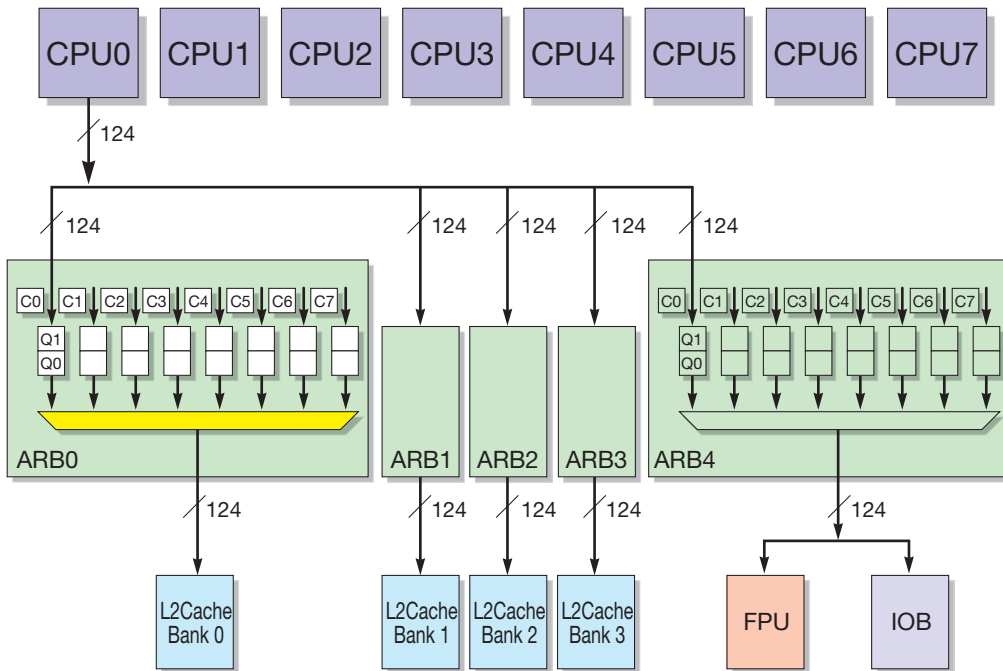

FIGURE 3-9 Data Flow in PCX Arbiter

ARB1, ARB2, and ARB3 receive packets for the L2-cache Bank1, Bank2, and Bank3 respectively. ARB4 receives packets for both the FPU and the I/O bridge.

3.4.3 PCX Arbiter Control Flow

This section describes the control flow inside ARB0 (the control flow is similar inside other arbiters).

ARB0 dispatches packets to the destination in the order it receives each packet. Therefore, a packet received in cycle 4 will be dispatched before a packet received in cycle 5. When multiple sources dispatch a packet in the same cycle, ARB0 follows a round-robin policy to arbitrate among packets from multiple sources.

A 5-bit bus originates from each CPU, and the bit corresponding to the destination is high while all other bits are low. Each arbiter receives one bit from the 5-bit bus from each CPU.

The arbitration scheme is implemented using a simple checkerboard as shown in [FIGURE 3-10](#).

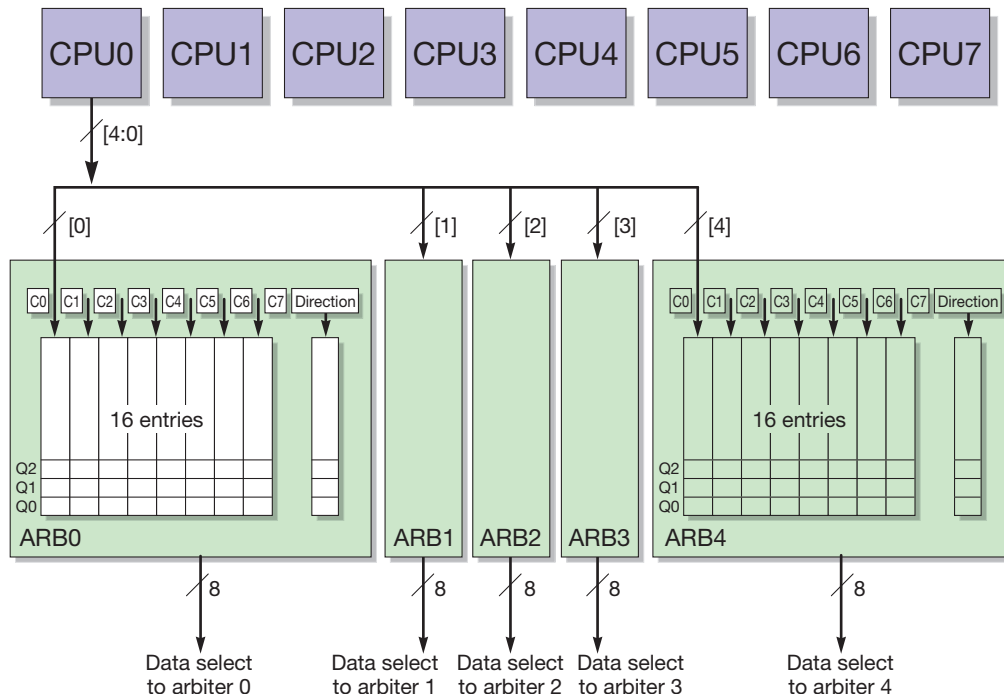

FIGURE 3-10 Control Flow in PCX Arbiter

The checkerboard consists of eight FIFOs. Each FIFO is sixteen entries deep, and each entry holds a single valid bit received from its corresponding CPU. Each valid FIFO entry represents a valid packet from a source for the L2-cache Bank0. Since each source can send at the most two entries for the L2-cache Bank0, there can be at

most two valid bits in each FIFO. Therefore, the entire checkerboard can have a maximum of 16 valid bits. This maximum represents the case when the L2-cache Bank0 is unable to process any new entry. The PCX reaches the maximum limit of storing two packets from each source.

There can be only one entry for each request, even if a request contains two packets. Such requests occupy one valid entry in the checkerboard and two FIFO entries in the data queue. A separate bit identifies a two-packet request.

The direction for the round-robin selection depends on the direction bit. Round-robin selection is left-to-right (C0 - C7) if the direction bit is high, or right-to-left (C7 - C0) if the direction bit is low. The direction bit toggles every cycle.

The direction bit is low for all arbiters at a reset. The direction bit toggles for all arbiters during every cycle. This requirement is required to maintain the TSO ordering for invalidates sent by an L2-cache bank.

ARB0 picks the first valid entry from the last row of the checkerboard every cycle. ARB0 then sends an 8-bit signal to the multiplexer at the output of the FIFOs storing the data (as show in [FIGURE 3-9](#)). The 8-bit signal is 1-hot, and the index of the high bit is same as the index of the entry picked in the last row. If there are multiple valid entries, ARB0 picks them in a round-robin fashion. ARB0 decides the direction for round-robin based on the direction bit.

3.5 CPX Internal Blocks Functional Description

3.5.1 CPX Overview

The CPX contains eight identical arbiter modules – one for each destination. The arbiters inside the CPX are identical to those inside PCX, so see [Section 3.4.1, “PCX Overview”](#) on page 3-17 for more information.

3.5.2 CPX Arbiters

Data and control flow inside the CPX are identical to those inside the PCX, so see [Section 3.4.2, “PCX Arbiter Data Flow”](#) on page 3-18 and [Section 3.4.3, “PCX Arbiter Control Flow”](#) on page 3-19 for more information.

Level 2 Cache

This chapter contains the following sections:

- [Section 4.1, “L2-Cache Functional Description” on page 4-1](#)
- [Section 4.2, “L2-Cache I/O LIST” on page 4-18](#)

4.1 L2-Cache Functional Description

The following sections describe the OpenSPARC T1 processor level 2 cache (L2-cache):

- [Section 4.1.1, “L2-Cache Overview” on page 4-1](#)
- [Section 4.1.2, “L2-Cache Single Bank Functional Description” on page 4-2](#)
- [Section 4.1.3, “L2-Cache Pipeline” on page 4-9](#)
- [Section 4.1.4, “L2-Cache Instruction Descriptions” on page 4-12](#)
- [Section 4.1.5, “L2-Cache Memory Coherency and Instruction Ordering” on page 4-17](#)

4.1.1 L2-Cache Overview

The OpenSPARC T1 processor L2-cache is 3 Mbytes in size and is composed of four symmetrical banks that are interleaved on a 64-byte boundary. Each bank operates independently of each other. The banks are 12-way set associative and 768 Kbytes in size. The block (line) size is 64 bytes, and each L2-cache bank has 1024 sets.

The L2-cache accepts requests from the SPARC CPU cores on the processor-to-cache crossbar (PCX) and responds on the cache-to-processor crossbar (CPX). The L2-cache is also responsible for maintaining the on-chip coherency across all L1-caches on the chip by keeping a copy of all L1 tags in a directory structure. Since the OpenSPARC

T1 processor implements system on a chip, with single memory interface and no L3 cache, there is no off-chip coherency requirement for the OpenSPARC T1 L2-cache other than it needs to be coherent with the main memory.

Each L2-cache bank has a 128-bit fill interface and a 64-bit write interface with the DRAM controller. Each bank had a dedicated DRAM channel, and each 32-bit word is protected by 7-bits of single error correction double error detection (SEC/DED) ECC code.

4.1.2 L2-Cache Single Bank Functional Description

The L2-cache is organized into four identical banks. Each bank has its own interface with the J-Bus, the DRAM controller, and the CPU-cache crossbar (CCX).

Each L2-cache bank interfaces with the eight SPARC CPU cores through a processor-cache crossbar (PCX). The PCX routes the L2-cache requests (loads, ifetches, stores, atomics, ASI accesses) from all of the eight CPUs to the appropriate L2-cache bank. The PCX also accepts read return data, invalidation packets, and store ACK packets from each L2-cache banks and forwards them to the appropriate CPU(s).

Each L2-cache bank interfaces with one DRAM controller in order to issue reads and evictions to the DRAM on misses in the L2-cache. A writeback gets issued 64-bits at a time to the DRAM controller. A fill happens 128-bits at a time from the DRAM controller to the L2-cache.

The L2-cache interfaces with the J-Bus interface (JBI) by way of the snoop input queue and the RDMA write buffer.

Each L2-cache bank consists of these three main sub-blocks:

- *sctag* (secondary cache tag) contains the tag array, VUAD array, L2-cache directory, and the cache controller
- *scbuf* contains write back buffer (WBB), fill buffer (FB) and DMA buffer
- *sdata* contains the *sdata* array

FIGURE 4-1 shows the various L2-cache blocks and their interfaces. The following paragraphs provide additional details about each functional block.

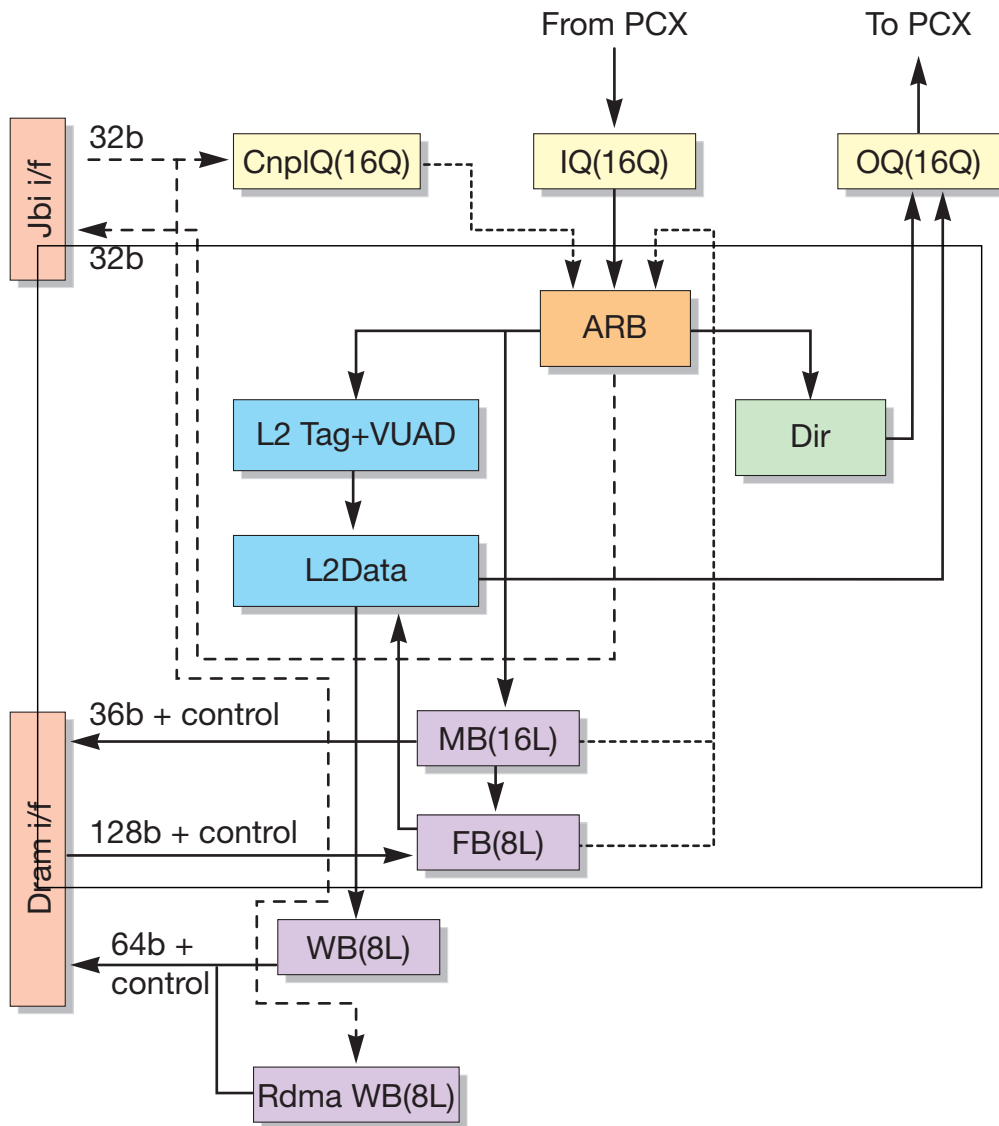

FIGURE 4-1 Flow Diagram and Interfaces for an L2-Cache Bank

4.1.2.1 Arbiter

The arbiter (ARB) manages the access to the L2-cache pipeline from the various sources that request access. The arbiter gets inputs from the following:

- Instructions from the CCX, and from the bypass path for input queue (IQ)
- DMA instructions from the snoop input queue (which is the RDMA input queue interface with the JBI)
- Instructions for recycle from the fill buffer and the miss buffer
- Stall signals from the pipeline (a stall condition will evaluate to true for a signal currently in the pipeline)

4.1.2.2 L2 Tag

The L2 tag block contains the *sctag* array and the associated control logic. Each 22-bit tag is protected by 6-bits of SEC ECC (the L2 tag does not support double-bit error detection). *sctag* is a single ported array, and it supports inline false hit detection. In the C1 stage of pipeline, the access address bits, as well the check bits, are compared. Therefore, there is never a false hit.

The state of each line is maintained using valid (V), used (U), allocated (A), and dirty (D) bits. These bits are stored in the L2 VUAD array.

4.1.2.3 L2 VUAD States

The four state bits for *sctags* are organized in a dual-ported array structure in the L2 VUAD array. The four states are – valid (V), used (U), allocated (A), and dirty (D). The used bit is not protected because a used error will not cause incorrect functionality. VAD bits are parity protected because an error will be fatal. The L2 VUAD array has two read and two write ports.

A valid bit indicates that the line is valid. The valid bit (per way) gets set when a new line is installed in that way. It gets reset when that line gets invalidated.

The used bit is a reference bit used in the replacement algorithm. The L2-cache uses a pseudo LRU algorithm for selecting a way to be replaced. There are 12 used bits per set in the L2-cache. The used bit gets set when there are any store/load hits (1 per way). Used bits get cleared (all 12 at a time) when there are no unused or unallocated entries for that set.

The allocate bit indicates that the marked line has been allocated to a miss. This bit is also used in the processing of some special instructions, such as atomics and *partial* stores. (Because these stores do read-modify-writes, which involve two passes through the pipe, the line needs to be locked until the second pass completes; otherwise, the line may get replaced before the second pass happens). The allocate

bit, therefore, acts analogous to a lock bit. The allocate bit (per way) gets set when a line gets picked for replacement. For a load or an ifetch, the bit gets cleared when a fill happens, and for a store when a store completes.

The dirty bit indicates that L2-cache contains the only valid copy of the line. The dirty bit (per way) gets set when a stores modifies the line. It gets cleared when the line is invalidated.

The pseudo least recently used (LRU) algorithm examines all the ways starting from a certain point in a round-robin fashion. The first unused, unallocated ways is selected for replacement. If no unused, unallocated way is found, then the first unallocated way is selected.

4.1.2.4 L2 Data (*sdata*)

The L2 data (*sdata*) array bank is a single ported SRAM structure. Each L2-cache bank is 768 Kbytes in size, with each logical line 64 bytes in size. The bank allows read access of 16 bytes and 64 bytes, and each cache line has 16 byte-enables to allow writing into each 4-byte part. However, a fill updates all 64 bytes at a time.

Each *sdata* array bank is further subdivided into four columns. Each column consists of six 32-Kbyte sub-arrays.

Any L2-cache data array access takes two cycles to complete, so no columns can be accessed in consecutive cycles. All access can be pipelined except back-to-back accesses to the same column. The *sdata* array has a throughput of one access per cycle.

Each 32-bit word is protected by seven bits of SEC/DED ECC. (Each line is $32 \times [32 + 7 \text{ ECC}] = 1248$ bits). All sub-word accesses require a read modify write operation to be performed, and they are referred to in this chapter as *partial stores*.

4.1.2.5 Input Queue

The input queue (IQ) is a 16-entry FIFO that queues packets arriving on the PCX when they cannot be immediately accepted into the L2-cache pipe. Each entry in the IQ is 130-bits wide

The FIFO is implemented with a dual-port array. The write port is used for writing into the IQ from the PCX interface. The read port is for reading contents for issue into the L2-cache pipeline. If the IQ is empty when a packet comes to the PCX, the packet can pass around the IQ if it is selected for issue to the L2-cache pipe. The IQ asserts a stall to the PCX when all eleven entries are used in the FIFO. This stall allows space for the packets already in flight.

4.1.2.6 Output Queue

The output queue (OQ) is a 16 entry FIFO that queues operations waiting for access to the CPX. Each entry in the OQ is 146-bits wide. The FIFO is implemented with a dual-ported array. The write port is used for writing into the OQ from the L2-cache pipe. The read port is used for reading contents for issue to the CPX. If the OQ is empty when a packet arrives from the L2-cache pipe, the packet can pass around the OQ if it is selected for issue to the CPX.

Multicast requests are dequeued from the FIFO only if all the of CPX destination queues can accept the response packet. When the OQ reaches its high-water mark, the L2-cache pipe stops accepting inputs from miss buffer or the PCX. Fills can happen while the OQ is full since they do not generate CPX traffic.

4.1.2.7 Snoop Input Queue

The Snoop input queue (SNPIQ) is a two-entry FIFO for storing DMA instructions coming from the JBI. The non-data portion (the address) is stored in the snoop input queue (SNPIQ). For a partial line write (WR8), both the control and the store data is stored in snoop input queue.

4.1.2.8 Miss Buffer

The 16-entry miss buffer (MB) stores instructions which cannot be processed as a simple cache hit. These instructions include true L2-cache misses (no tag match), instructions that have the same cache line address as a previous miss or an entry in the writeback buffer, instructions requiring multiple passes through the L2-cache pipeline (atomics and partial stores), unallocated L2-cache misses, and accesses causing tag ECC errors.

The miss buffer is divided into a non-tag portion which holds the store data, and a tag portion which contains the address. The non-tag portion of the buffer is a RAM with 1 read and 1 write port. The tag portion is a CAM with 1 read, 1 write, and 1 cam port.

A read request is issued to the DRAM and the requesting instruction is replayed when the *critical quad-word* of data arrives from the DRAM.

All entries in the miss buffer that share the same cache line address are linked in the order of insertion in order to preserve the coherency. Instructions to the same address are processed in age order, whereas instructions to different addresses are not ordered and exist as a free list.

When an MB entry gets picked for issue to the DRAM (such as a load, store, or ifetch miss), the MB entry gets copied into the fill buffer and a valid bit gets set. There can be up to 8 reads outstanding from the L2-cache to the DRAM at any point of time.

Data can come from the DRAM to the L2-cache out of order with respect to the address order. When the data comes back out of order, the MB entries get readied for issue in the order of the data return. This means that there is no concept of age in the order of data returns to the CPU as these are all independent accesses to different addresses. Therefore, when a later read gets replayed from the MB down the pipe and invalidates its slot in the MB, a new request from the pipe will take its slot in the MB, even while an older read has not yet returned data from the DRAM.

In most cases, when a data return happens, the replayed load from the MB makes it through the pipe before the fill request can. Therefore, the valid bit of the MB entry gets cleared (after the replayed MB instruction execution is complete in the pipe) before the fill buffer valid bit. However, if there are other prior MB instructions, like partial stores that get picked instead of the MB instruction of concern, the fill request can enter the pipe before the MB instruction. In these cases, the valid bit in the fill buffer gets cleared prior to the MB valid bit. Therefore, the MB valid bit and FB valid bits always get set in the order of MB valid bit first, and FB valid bit second. (These bits can get cleared in any order, however.)

4.1.2.9 Fill Buffer

The fill buffer (FB) contains a cache-line wide entry to the stage data from the DRAM before it fills the cache. Addresses are also stored for maintaining the age ordering in order to satisfy coherency conditions.

The fill buffer is an 8 entry buffer used to temporarily store data arriving from the DRAM on an L2-cache miss request. Data arrives from the DRAM in four 16-byte blocks starting with the critical quad-word. A load instruction waiting in the miss buffer can enter the pipeline after the critical quad-word arrives from the DRAM (the critical 16 bytes will arrive first from the DRAM). In this case, the data is bypassed. After all four quad-words arrive, the fill instruction enters the pipeline and fills the cache (and the fill buffer entry gets invalidated).

When data comes back in the FB, the instruction in the MB gets readied for reissue and the cache line gets written into the data array. These two events are independent and can happen in any order.

For a non-allocating read (for example, an I/O read), the data gets drained from the fill buffer directly to the I/O interface when the data arrives (and the fill buffer entry gets invalidated). When the FB is full, the miss buffer cannot make requests to the DRAM.

The fill buffer is divided into a RAM portion, which stores the data returned from the DRAM waiting for a fill to the cache, and a CAM portion, which contains the address. The fill buffer has a read interface with the DRAM controller.

4.1.2.10 Writeback Buffer

The writeback buffer (WBB) is an eight entry buffer used to store the 64-byte evicted dirty data line from the L2-cache. The replacement algorithm picks a line for eviction on a miss. The evicted lines are streamed out to the DRAM opportunistically. An instruction whose cache line address matches the address of an entry in the WBB is inserted into the miss buffer. This instruction must wait for the entry in the WBB to write to the DRAM before entering the L2-cache pipe.

The WBB is divided into a RAM portion, which stores the evicted data until it can be written to the DRAM, and a CAM portion, which contains the address.

The WBB has a 64-byte read interface with the *sdata* array and a 64-bit write interface with the DRAM controller. The WBB reads from the *sdata* array faster than it can flush data out to the DRAM controller.

4.1.2.11 Remote DMA Write Buffer

The remote DMA (RDMA) write buffer is a four entry buffer that accommodates the cache line for a 64-byte DMA write. The output interface is with the DRAM controller that it shares with the WBB. The WBB has a direct input interface with the JBI.

4.1.2.12 L2-Cache Directory

Each L2-cache directory has 2048 entries, with one entry per L1 tag that maps to a particular L2-cache bank. Half of the entries correspond to the L1 instruction-cache (icache) and the other half of the entries correspond to the L1 data-cache (dcache). The L2 directory participates in coherency management and it also maintains the inclusive property of the L2-cache.

The L2-cache directory also ensures that the same line is not resident in both the icache and the dcache (across all CPUs). The L2-cache directory is written in the C5 cycle of a load or an I-miss that hits the L2-cache, and is cammed in the C5 cycle of a store/streaming store operation that hits the L2-cache. The lookup operation is performed in order to invalidate all the SPARC L1-caches that own the line other than the SPARC core that performed the store.

The L2-cache directory is split into an icache directory (icdir) and a dcache directory (dcdir), which are both similar in size and functionality.

The L2-cache directory is written only when a load is performed. On certain data accesses (loads, stores and evictions), the directory is cammed to determine whether the data is resident in the L1-caches. The result of this CAM operation is a set of

match bits which are encoded to create an invalidation vector that is to be sent back to the SPARC CPU cores to invalidate the L1-cache lines. Descriptions of these data access are as follows:

- Loads – The icdir is cammed to maintain I/D exclusivity. The dcdir is updated to reflect the load data that fills the L1-cache.
- IFetch – The dcdir is cammed to maintain the I/D exclusivity. The icdir is updated to reflect the instruction data that fills the L1-cache.
- Stores – Both directories are cammed, which ensures that (1) if the store is to instruction space, the L1 icache invalidates the line and does not pick up stale data; (2) if a line is shared across SPARC CPUs, the L1 dcache invalidates the other CPUs and does not pick up the stale data; and (3) the issuing CPU has the most current information on the validity of its line.
- Evictions from the L2-cache – Both directories are cammed to invalidate any line that is no longer resident in the L2-cache.

The dcache directory is organized as sixteen panels with sixty-four entries in each panel. Each entry number is formed using the cpu ID, way number, and bit 8 from the physical address. Each panel is organized in four rows and four columns. The icache directory is organized similarly. For an eviction, all four rows are cammed.

4.1.3 L2-Cache Pipeline

This section describes the L2-cache transaction types and the stages of the L2-cache pipeline.

4.1.3.1 L2-Cache Transaction Types

The L2-cache processes three main types of instructions:

- Requests from a CPU by way of the PCX
- Requests from the I/O by way of the JBI
- Requests from the IOB by way of the PCX

The requests from a CPU include the following instructions – load, streaming load, Ifetch, prefetch, store, streaming store, block store, block init store, atomics, interrupt, and flush.

The requests from the I/O include the following instructions – block read (RD64), write invalidate (WRI), and partial line write (WR8).

The requests from the I/O buffer includes the following instructions – forward request load and forward request store (these instructions are used for diagnostics). The test access port (TAP) device cannot talk to the L2-cache directly. The TAP

performs diagnostic reads from the JTAG or the L2-cache, and it sends a request to a CPU by way of the CPX. The CPU bounces the request to the L2-cache by way of the PCX.

4.1.3.2 L2-Cache Pipeline Stages

The L2-cache access pipeline has eight stages (C1 to C8), and the following sections describe the logic executed during each stage of the pipeline.

C1

- All buffers (WBB, WB and MB) are cammed. The instruction is a dependent instruction if the instruction address is found in any of the buffers.
- Generate ECC for store data.
- Access VUAD and TAG array to establish a miss or a hit.

C2

- Pipeline stall conditions are evaluated. The following conditions require that the pipeline be stalled:
 - 32-byte access requires two cycles in the pipeline.
 - An I-miss instruction stalls the pipeline for one cycle. When an I-miss instruction is encountered in the C2 stage, it stalls the instruction in the C1 stage so that it stays there for two cycles. The instruction in the C1 stage is replayed.
- For instructions that hit the cache, the way-select generation is completed.
- Pseudo least recently used (LRU) is used for selecting a way for replacement in case of a miss.
- VUAD is updated in the C5 stage. However, VUAD is accessed in the C1 stage. The bypass logic for VUAD generation is completed in the C2 stage. This process ensures that the correct data is available to the current instruction from the previous instructions because the C2 stage of the current instruction completes before the C5 stage of the last instruction.
- The miss buffer is cammed in the C1 stage. However, the MB is written in the C3 stage. The bypass logic for a miss buffer entry generation is completed in the C2 stage. This ensures that the correct data is available to the current instruction from previous instructions, because the C2 stage of the current instruction starts before the C3 stage of the last instruction completes.

C3

- The set and way select is transmitted to *sdata*.
- An entry is created in miss buffer for instructions that miss the cache.

C4

- The first cycle of read or write to the *sdata* array for load/store instructions that hit the cache.

C5

- The second cycle of read or write to the *sdata* array for load/store instructions that hit the cache.
- Write into the L2-cache directory for loads, and CAM the L2-cache directory for stores.
- Write the new state of line into the VUAD array (by now the new state of line has been computed).
- Fill buffer bypass – If the data to service the load that missed the cache is available in the FB, then do not wait for the data to be available in the data array. The FB provides the data directly to the pipeline.

C6

- 128-bits of data and 28-bits of ECC are transmitted from the *sdata* (data array) to the *sctag* (tag array).

C7

- Error correction is done by the *sctag* (data array).
- The *sctag* sends the request packet to the CPX, and the *sctag* is the only interface the L2-cache has with the CPX.

C8

- A data packet is sent to the CPX. This stage corresponds with the CQ stage of the CPX pipeline.

Cache miss instructions are reissued from the miss buffer after the data returns from the DRAM controller. These reissued instructions follow the preceding pipeline.

4.1.4 L2-Cache Instruction Descriptions

The following instructions follow a skewed pipeline. They do not follow the simple pipeline like the one described in [Section 4.1.3, “L2-Cache Pipeline”](#) on page 4-9.

4.1.4.1 Loads

A load instruction to the L2-cache is caused by any one of the following conditions:

- A miss in the L1-cache (the primary cache) by a load, prefetch, block load, or a quad load instruction.
- A streaming load issued by the stream processing unit (SPU)
- A forward request read issued by the IOB

The output of the *sdata* array, returned by the load, is 16 bytes in size. This size is same as the size of the L1 data cache line. An entry is created in the dcache directory. An icache directory entry is invalidated if it exists. An icache directory entry is invalidated for L1-cache of every CPU in which it exists.

From an L2-cache perspective, a block load is the same as eight load requests. A quad load is same as four load requests.

A prefetch instruction is issued by a CPU and is identical to a load, except for this one difference – the results of a prefetch are not written into the L1-cache and therefore the tags are not copied into the L2-cache directory.

From an L2-cache perspective, a streaming load behaves same as a normal load except for one difference. The L2-cache understands that it will not install the data in the L1-cache. Therefore, the dcache entry is not created and the icache entries are not invalidated. The L2-cache returns 128-bits of data.

A forward request read returns 39-bits (32 + 7 ECC) of data. The data is returned without an ECC check. Since the forward request load is not installed in the L1-cache, there is no L2-cache directory access.

4.1.4.2 Ifetch

An ifetch is issued to the L2-cache in response to an instruction missing the L1 icache. The size of icache is 256-bits. The L2-cache returns the 256-bits of data in two packets over two cycles to the requesting CPU over the CPX. The two packets are returned as an atomic. The L2-cache then creates an entry in the icache directory and invalidates any existing entry in the dcache directory.

4.1.4.3 Stores

A store instruction to L2-cache is caused by any of the following conditions:

- A miss in the L1-cache by a store, block store, or a block init store instruction.
- A streaming store issued by the stream processing unit (SPU).
- A forward request write issued by the IOB.

The store instruction writes (in a granularity of) 32-bits of data into the *sdata* array. An acknowledgment packet is sent to the CPU that issued the request, and an invalidate packet is sent to all other CPUs. The icache directory entry for every CPU is cammed and invalidated. The dcache directory entry of every CPU, except the requesting CPU, is cammed and invalidated.

A block store is the same as eight stores from an L2-cache perspective. A block init store is same as a block store except for one difference – in the case of a miss for a block init store, a dummy read request is issued to the DRAM controller. The DRAM controller returns a line filled with all zeroes. Essentially, this line return saves DRAM read bandwidth.

The LSU treats every store as a total store order (TSO) store. The LSU waits for an acknowledgement to arrive before processing the next store. However, block init stores can be processed without waiting for acknowledgements.

From the L2-cache's perspective, a streaming store is the same as a store.

A forward request write stores 64-bits of data in the *sdata*. The icache and the dcache directory entries are not cammed afterwards.

The forward request write and the streaming store may stride a couple of words and therefore may require partial stores.

Partial stores (PST) perform sub-32-bit writes into the *sdata* array. As mentioned earlier, the granularity of the writes into the *sdata* is 32-bits. A partial stores is executed as a read-modify-write operation. In the first step the cache line is read and merged with the write data. It is then saved in the miss buffer. The cache line is written into the *sdata* array in the second pass of the instruction through the pipe.

4.1.4.4 Atomics

The L2-cache processes three types of atomic instructions – load store unsigned byte (LDSTUB), SWAP, and compare and swap (CAS). These instructions require two passes down the L2-cache pipeline.

LDSTUB/SWAP

The instruction reads a byte from memory into a register, and then it writes 0xFF into memory in a single, indivisible operation. The value in the register can then be examined to see if it was already 0xFF, which means that another processor got there first. If the value is 0x00, then this processor is in charge. This instruction is used to make mutual exclusion locks (known as mutexes) that make sure only one processor at a time can hold the lock. The lock is acquired through the LDSTUB and cleared by storing 0x00 back to the memory.

The first pass reads the addressed cache line and returns 128-bits of data to the requesting CPU. It also merges it with unsigned-byte/swap data. This merged data is written into the miss buffer.

In the second pass of the instruction, the new data is stored in the *scdata* array. An acknowledgement is sent to the issuing CPU and the invalidation is sent to all other CPUs appropriately. The icache and the dcache directories are cammed and the entries are invalidated. In case of atomics, the directory entry of even the issuing CPU is invalidated.

CAS/CAS(X)

CAS{X} instructions are handled as two packets on the PCX. The first packet (CAS(1)) contains the address and the data (against which the read data will be compared).

The first pass reads the addressed cache line and sends 128-bits of data read back to the requesting CPU. (The comparison is performed in the first pass.)

The second packet (CAS(2)) contains the store data. The store data is inserted into the miss buffer as a store at the address contained in the first packet. If the comparison result is true, the second pass proceeds like a normal store. If the result was false, the second pass proceeds to generate the store acknowledgment only. The *scdata* array is not written.

4.1.4.5 J-Bus Interface Instructions

I/O requests are sent to the L2-cache by way of the J-Bus interface (JBI). The L2-cache processes the following instructions from a JBI – block read (RD64), write invalidate (WRI), and partial line write (WR8).

Block Read

A block read (RD64) from the JBI goes through the L2-cache pipe like a regular load from the CPU. On a hit, 64 bytes of data is returned to the JBI. On a miss, the L2-cache does not allocate, but sends a non-allocating read to the DRAM. It gets 64 bytes of data from the DRAM and sends it back to the JBI directly (read once data only) without installing it in the L2-cache. The CTAG (the instruction identifier) and the 64-byte data is returned to the JBI on a 32-bit interface.

Write Invalidate

For a 64-byte write (the write invalidate (WRI) from the JBI), the JBI issues a 64-byte write request to the L2-cache.

When the write progresses through the pipe, it looks up the tags. If a tag hit occurs, it invalidates the entry and all primary cache entries that match. If a tag miss occurs, it does nothing (it just continues down the pipe) to maintain the order.

Data is not written into the *sdata* cache on a miss. However, the *sdata* entry, and all primary cache lines, are invalidated on a hit.

The CTAG (the instruction identifier) is returned to the JBI when the processor sends an acknowledgement to the cache line invalidation request sent over the CPX.

After the instruction is retired from the pipe, 64 bytes of data is written to the DRAM.

Partial Line Write

A partial line write (WR8) supports the writing of any subset of 8 bytes to the *sdata* array by the JBI. However, the bytes written have to be contiguous. The JBI breaks down any store that is not composed of contiguous bytes.

When the JBI issues 8-byte writes to the L2-cache with random byte enables, the L2-cache treats them just like 8-bytes stores from the CPU. (That is, it does a two-pass partial store if an odd number of byte enables are active or if there is a misaligned access. Otherwise, it does a regular store.)

Data is written into the *sdata* cache on a miss (allocated).

The CTAG (the instruction identifier) is returned to the JBI when the processor sends an acknowledgement to the cache line invalidation request sent over the CPX.

The directory entry is not created in the case of a miss.

4.1.4.6 Eviction

When a load or a store instruction is a miss in the L2-cache, a request goes to the DRAM controller to bring the cache line from the main memory. Before the arriving data can be installed, one of the ways must be evicted. The pseudo LRU algorithm described earlier picks the way to be evicted.

The L2-cache (*sdata*) includes all valid L1-cache lines. In order to preserve the inclusion, the L2-cache directory (both icache and dcache) is cammed with the evicted tag, and the corresponding entry is invalidated. The invalidated packets are all sent to the appropriate CPUs.

If the evicted line is dirty, it is written into the write back buffer (WBB). The WBB opportunistically streams out the cache line to the DRAM controller over a 64-bit bus.

4.1.4.7 Fill

A fill is issued following an eviction after an L2-cache store or load miss. The 64-byte data arrives from the DRAM controller and is stored in the fill buffer. Data is read from the fill buffer and written into the L2-cache *sdata* array.

4.1.4.8 Other Instructions

L1-Cache Invalidation

The instruction invalidates the four primary cache entries as well as the four L2-cache directory entries corresponding to each primary cache tag entry. The invalidation is issued whenever the CPU detects a parity error in the tags of I-cache or dcache.

Interrupts

When a thread wants to send an interrupt to another thread, it sends it through the L2-cache. The L2-cache treats the thread like a bypass. After a decode, the L2-cache sends the instruction back to destination CPU if it is an interrupt.

Flush

From the L2-cache's perspective, a flush is a broadcast. The OpenSPARC T1 processor requires this flush instruction. Whenever a self-modifying code is performed, the first instruction at the end of the self-modifying sequence should come from a new stream.

An interrupt with a BR=1 is broadcast to all CPUs. (Such an interrupt is issued by a CPU in response to a flush instruction.)

A flush stays in the output queue until all eight receiving queues are available. This is a total store order (TSO) requirement.

4.1.5 L2-Cache Memory Coherency and Instruction Ordering

Cache coherency is maintained using a mixture of structures in the miss buffer, fill buffer, and the write back buffer. The miss buffer maintains a dependency list for the access to the 64 bytes of cache lines with the same address. Responses are sent to the CPUs in the age order of the requests for the same address.

The L2-cache directory maintains the cache coherency in all primary caches. The L2-cache directory preserves the inclusion property – all valid entries in the primary cache should reside in the L2-cache as well. It also keeps the icache and the dcache exclusive for each CPU.

The read after write (RAW) dependency to the DRAM controller is resolved by camming the write back buffer on a load miss.

Multicast requests (for example, a flush request) are sent to the CPX only if all of the receiving queues are available. This process is a requirement for maintaining the total store order (TSO).

4.2 L2-Cache I/O LIST

The following tables describe the L2-cache I/O signals.

TABLE 4-1 SCDATA I/O Signal List

Signal Name	I/O	Source/ Destination	Description
cmp_gclk[1:0]	In	CTU	Clock
global_shift_enable	In	CTU	To data of bw_r_l2d.v
si	In	DFT	Scan in
arst_l,	In	CTU	
cluster_cken	In	CTU	
ctu_tst_pre_grst_l	In	CTU	
ctu_tst_scanmode	In	CTU	
ctu_tst_scan_disable	In	CTU	
ctu_tst_macrotest	In	CTU	
ctu_tst_short_chain	In	CTU	
efc_scd_data_fuse_ashift	In	EFC	To efuse_hdr of scdata_efuse_hdr.v
efc_scd_data_fuse_clk1	In	EFC	To efuse_hdr of scdata_efuse_hdr.v, and so on.
efc_scd_data_fuse_clk2	In	EFC	To efuse_hdr of scdata_efuse_hdr.v, and so on.
efc_scd_data_fuse_data	In	EFC	To efuse_hdr of scdata_efuse_hdr.v
efc_scd_data_fuse_dshift	In	EFC	To efuse_hdr of scdata_efuse_hdr.v
scbuf_scd_data_fbdecc_c4[623:0]	In	SCBUF	To periph_io of scdata_periph_io.v
sctag_scd_data_col_offset_c2[3:0]	In	SCTAG	
sctag_scd_data_fb_hit_c3	In	SCTAG	To rep of scdata_rep.v
sctag_scd_data_fbrd_c3	In	SCTAG	To rep of scdata_rep.v
sctag_scd_data_rd_wr_c2	In	SCTAG	To rep of scdata_rep.v
sctag_scd_data_set_c2[9:0]	In	SCTAG	To rep of scdata_rep.v
sctag_scd_data_stdecc_c2[77:0]	In	SCTAG	To rep of scdata_rep.v
sctag_scd_data_way_sel_c2[11:0]	In	SCTAG	
sctag_scd_data_word_en_c2[15:0]	In	SCTAG	
so	Out	DFT	Scan out

TABLE 4-1 SCDATA I/O Signal List (*Continued*)

Signal Name	I/O	Source/ Destination	Description
scdata_efc_fuse_data	Out	EFC	From efuse_hdr of scdata_efuse_hdr.v
scdata_scbuf_decc_out_c7[623:0]	Out	SCBUF	
scdata_sctag_decc_c6[155:0]	Out	SCTAG	From rep of scdata_rep.v

TABLE 4-2 SCBUF I/O Signal List

Signal Name	I/O	Source/ Destination	Description
sctag_scbuf_fbrd_en_c3	In	SCTAG	rd en for a fill operation or fb bypass
sctag_scbuf_fbrd_wl_c3[2:0]	In	SCTAG	
sctag_scbuf_fbwr_wen_r2[15:0]	In	SCTAG	
sctag_scbuf_fbwr_wl_r2[2:0]	In	SCTAG	
sctag_scbuf_fbd_stdatsel_c3	In	SCTAG	Select store data in OFF mode
sctag_scbuf_stdecc_c3[77:0]	In	SCTAG	Store data goes to scbuf and scdata
sctag_scbuf_evict_en_r0	In	SCTAG	
sctag_scbuf_wbwr_wen_c6[3:0]	In	SCTAG	Write en
sctag_scbuf_wbwr_wl_c6[2:0]	In	SCTAG	From wbctl
sctag_scbuf_wbrd_en_r0	In	SCTAG	Triggered by a wr_ack from DRAM
sctag_scbuf_wbrd_wl_r0[2:0]	In	SCTAG	
sctag_scbuf_ev_dword_r0[2:0]	In	SCTAG	
sctag_scbuf_rdma_wren_s2[15:0]	In	SCTAG	
sctag_scbuf_rdma_wrwl_s2[1:0]	In	SCTAG	
jbi_sctag_req[31:0]	In	JBI	
jbi_scbuf_ecc[6:0]	In	JBI	
sctag_scbuf_rdma_rden_r0	In	SCTAG	
sctag_scbuf_rdma_rdw1_r0[1:0]	In	SCTAG	
sctag_scbuf_ctag_en_c7	In	SCTAG	
sctag_scbuf_ctag_c7[14:0]	In	SCTAG	
sctag_scbuf_req_en_c7	In	SCTAG	
sctag_scbuf_word_c7[3:0]	In	SCTAG	

TABLE 4-2 SCBUF I/O Signal List (*Continued*)

Signal Name	I/O	Source/ Destination	Description
sctag_scbuf_word_vld_c7	In	SCTAG	
scdata_scbuf_decc_out_c7[623:0]	In	SCDATA	
dram_scbuf_data_r2[127:0]	In	DRAM	
dram_scbuf_ecc_r2[27:0]	In	DRAM	
cmp_gclk	In	CTU	Clock
arst_l	In	CTU	Asynchronous reset
grst_l	In	CTU	Synchronous reset
global_shift_enable,	In	CTU	
cluster_cken	In	CTU	
ctu_tst_pre_grst_l	In	CTU	
ctu_tst_scanmode	In	CTU	
ctu_tst_scan_disable	In	CTU	
ctu_tst_macrotest	In	CTU	
ctu_tst_short_chain	In	CTU	
scbuf_sctag_ev_uerr_r5	Out	SCTAG	
scbuf_sctag_ev_cerr_r5	Out	SCTAG	
scbuf_jbi_ctag_vld	Out	JBI	
scbuf_jbi_data[31:0]	Out	JBI	
scbuf_jbi_ue_err	Out	JBI	
scbuf_sctag_rdma_uerr_c10	Out	SCTAG	
scbuf_sctag_rdma_cerr_c10	Out	SCTAG	
scbuf_scdata_fbdecc_c4[623:0]	Out	SCDATA	
scbuf_dram_data_mecc_r5	Out	DRAM	
scbuf_dram_wr_data_r5[63:0]	Out	DRAM	
scbuf_dram_data_vld_r5	Out	DRAM	
so	Out	DFT	Scan out

TABLE 4-3 SCTAG I/O Signal List

Signal Name	I/O	Source/ Destination	Description
pcx_sctag_data_rdy_px1	In	CCX:PCX	PCX data ready
pcx_sctag_data_px2[123:0]	In	CCX:PCX	PCX to sctag packet
pcx_sctag_atm_px1	In	CCX:PCX	Indicates that the current packet is atomic
cp_x_sctag_grant_cx[7:0]	In	CCX:CPX	CPX grant
scdata_sctag_decc_c6[155:0]	In	SCDATA	From data of scdata_data.v
scbuf_sctag_ev_uerr_r5	In	SCBUF	
scbuf_sctag_ev_cerr_r5	In	SCBUF	
scbuf_sctag_rdma_uerr_c10	In	SCBUF	
scbuf_sctag_rdma_cerr_c10	In	SCBUF	
dram_sctag_rd_ack	In	DRAM	
dram_sctag_wr_ack	In	DRAM	
dram_sctag_chunk_id_r0[1:0]	In	DRAM	
dram_sctag_data_vld_r0	In	DRAM	
dram_sctag_rd_req_id_r0[2:0]	In	DRAM	
dram_sctag_secc_err_r2	In	DRAM	
dram_sctag_mecc_err_r2	In	DRAM	
dram_sctag_scb_mecc_err	In	DRAM	
dram_sctag_scb_secc_err	In	DRAM	
jbi_sctag_req_vld	In	JBI	
jbi_sctag_req[31:0]	In	JBI	
arst_l	In	CTU	Asynchronous reset
grst_l	In	CTU	Synchronous reset
adbginit_l	In	CTU	Asynchronous reset
gdbginit_l	In	CTU	Synchronous reset
cluster_cken	In	CTU	
cmp_gclk	In	CTU	Global clock input to cluster header
global_shift_enable	In	CTU	
ctu_sctag_mbisten	In	CTU	
ctu_sctag_scanin	In	CTU	

TABLE 4-3 SCTAG I/O Signal List (*Continued*)

Signal Name	I/O	Source/ Destination	Description
sdata_sctag_scanout	In	DFT	Scan in
ctu_tst_macrotest	In	CTU	To test_stub of test_stub_bist.v
ctu_tst_pre_grst_l	In	CTU	To test_stub of test_stub_bist.v
ctu_tst_scan_disable	In	CTU	To test_stub of test_stub_bist.v
ctu_tst_scanmode	In	CTU	To test_stub of test_stub_bist.v
ctu_tst_short_chain	In	CTU	To test_stub of test_stub_bist.v
efc_sctag_fuse_clk1	In	EFC	
efc_sctag_fuse_clk2	In	EFC	
efc_sctag_fuse_ashift	In	EFC	
efc_sctag_fuse_dshift	In	EFC	
efc_sctag_fuse_data	In	EFC	
sctag_cpx_req_cq[7:0]	Out	CCX:CPX	sctag to processor request
sctag_cpx_atom_cq	Out	CCX:CPX	Atomic request
sctag_cpx_data_ca[144:0]	Out	CCX:CPX	sctag to cpx data pkt
sctag_pcx_stall_pq	Out	CCX:PCX	sctag to pcx IQ_full stall
sctag_jbi_por_req	Out	JBI	
sctag_sdata_way_sel_c2[11:0]	Out	SCDATA	
sctag_sdata_rd_wr_c2	Out	SCDATA	
sctag_sdata_set_c2[9:0]	Out	SCDATA	
sctag_sdata_col_offset_c2[3:0]	Out	SCDATA	
sctag_sdata_word_en_c2[15:0]	Out	SCDATA	
sctag_sdata_fbrd_c3	Out	SCDATA	From arbctl of sctag_arbctl.v
sctag_sdata_fb_hit_c3	Out	SCDATA	Bypass data from Fb
sctag_sdata_stdecc_c2[77:0]	Out	SCDATA	
sctag_scbuf_stdecc_c3[77:0]	Out	SCBUF	
sctag_scbuf_fbrd_en_c3	Out	SCBUF	rd en for a fill operation or fb bypass
sctag_scbuf_fbrd_wl_c3[2:0]	Out	SCBUF	
sctag_scbuf_fbwr_wen_r2[15:0]	Out	SCBUF	
sctag_scbuf_fbwr_wl_r2[2:0]	Out	SCBUF	
sctag_scbuf_fbd_stdatasel_c3	Out	SCBUF	Select store data in OFF mode

TABLE 4-3 SCTAG I/O Signal List (*Continued*)

Signal Name	I/O	Source/ Destination	Description
sctag_scbuf_wbwr_wen_c6[3:0]	Out	SCBUF	Write en
sctag_scbuf_wbwr_wl_c6[2:0]	Out	SCBUF	From wbctl
sctag_scbuf_wbrd_en_r0	Out	SCBUF	Triggerred by a wr_ack from dram
sctag_scbuf_wbrd_wl_r0[2:0]	Out	SCBUF	
sctag_scbuf_ev_dword_r0[2:0]	Out	SCBUF	
sctag_scbuf_evict_en_r0	Out	SCBUF	
sctag_scbuf_rdma_wren_s2[15:0]	Out	SCBUF	May be all 1s
sctag_scbuf_rdma_wrwl_s2[1:0]	Out	SCBUF	
sctag_scbuf_rdma_rdw1_r0[1:0]	Out	SCBUF	
sctag_scbuf_rdma_rden_r0	Out	SCBUF	
sctag_scbuf_ctag_en_c7	Out	SCBUF	
sctag_scbuf_ctag_c7[14:0]	Out	SCBUF	
sctag_scbuf_word_c7[3:0]	Out	SCBUF	
sctag_scbuf_req_en_c7	Out	SCBUF	
sctag_scbuf_word_vld_c7	Out	SCBUF	This signal is high for 16 signals.
sctag_dram_rd_req	Out	DRAM	
sctag_dram_rd_dummy_req	Out	DRAM	
sctag_dram_rd_req_id[2:0]	Out	DRAM	
sctag_dram_addr[39:5]	Out	DRAM	
sctag_dram_wr_req	Out	DRAM	
sctag_jbi_iq_dequeue	Out	JBI	Implies that an instruction has been issued
sctag_jbi_wib_dequeue	Out	JBI	Implies that an entry in the rdma array has freed.
sctag_dbgbus_out[40:0]	Out	IOB	Debug bus
sctag_clk_tr	Out		
sctag_ctu_mbistdone	Out	CTU	MBIST done
sctag_ctu_mbisterr	Out	CTU	MBIST error
sctag_ctu_scanout	Out	DFT	Scan out
sctag_scbuf_scanout	Out	DFT	Scan out
sctag_efc_fuse_data	Out	EFC	From red_hdr of cmp_sram_redhdr.v

Input/Output Bridge

This chapter describes the following topics:

- [Section 5.1, “Functional Description” on page 5-1](#)
- [Section 5.2, “I/O Bridge Signal List” on page 5-12](#)

5.1 Functional Description

The input/output bridge (IOB) is the interface between the CPU-cache crossbar (CCX) and the rest of the blocks in the OpenSPARC T1 processor. The main IOB functions include:

- I/O address decoding:
 - IOB maps or decodes I/O addresses to the proper internal or external destination.
 - IOB generates control/status register (CSR) accesses to the IOB, JBI, DRAM, and CTU clusters.
 - IOB generates programmed I/O (PIO) accesses to the external J-Bus.
- Interrupts:
 - IOB collects the interrupts from clusters (errors and EXT_INT_L) and mondo interrupts from the J-Bus.
 - IOB forwards interrupts to the proper core and thread.
 - IOB wakes up a single thread at reset.
- Interface between the read/write/iffill to the SSI.
- IOB provides test port access (TAP) access to CSRs, Memory, L2-cache, and CPU ASIs.
- IOB provides debug Port functionality (both to an external debug port and to the JBI).
- IOB operates in both the CMP and J-Bus clock domains.

5.1.1 IOB Interfaces

FIGURE 5-1 shows the interfaces to and from the IOB to the rest of the blocks and clusters.

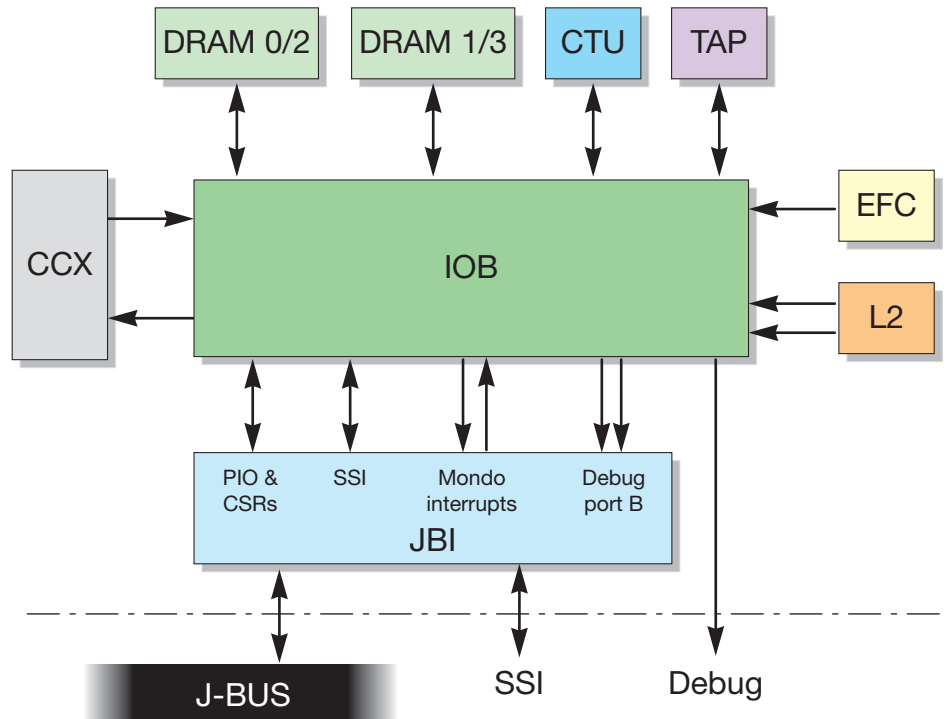

FIGURE 5-1 IOB Interfaces

The main interfaces to and from the IOB are:

- Crossbar (CCX): interface to the PCX to the CPX (both are parallel interfaces).
- Universal connection bus (UCB) interface is a common packetized interface to all clusters for CSR accesses.
 - Common width-parameterized blocks in the IOB and clusters.
 - The separate request and acknowledge/interrupt paths with parameterized widths, various blocks, and widths are defined in TABLE 5-1.

TABLE 5-1 UCB interfaces to Clusters

Cluster/Block	Width from IOB to block	Width from block to IOB
CTU	4 bits	4 bits
DRAM02 and DRAM13	4 bits	4 bits
JBI PIO	64 bits	16 bits
JBI SSI	4 bits	4 bits
TAP	8 bits	8 bits

- In most of the UCB interfaces, the IOB is master and the cluster/block is a slave, with the exception of the TAP. The TAP interface is unique – it is both master and slave.
- All UCB interfaces are visible through the debug ports.
- J-Bus Mondo Interrupt Interface:
 - 16-bit request interface and a valid bit.
 - Header with 5-bit source and target (thread) IDs.
 - 8 cycles of data - 128 bits (J-Bus Mondo Data 0 & 1).
 - 2-bit acknowledge interface - ACK / NACK.
- Efuse Controller (EFC) – Serial Interface:
 - Shifted-in at power-on-reset (POR) to make the software visible (read-only).
 - CORE_AVAIL, PROC_SER_NUM.
- Debug Ports:
 - Internal visibility port on each UCB interface.
 - L2-cache visibility port input from the L2-cache (2 x 40-bits @ CMP clock).
 - Debug port A output to the debug pads (40-bits @ J-Bus clock).
 - Debug port B output to the JBI (2 x 48-bits @ J-Bus clock).

5.1.2 UCB Interface

FIGURE 5-2 shows the UCB interface from and to cluster. There are two uni-directional ports – one from the IOB to the cluster and one from the cluster to the IOB. Each port consists of a valid signal, a data packet, and a stall signal.

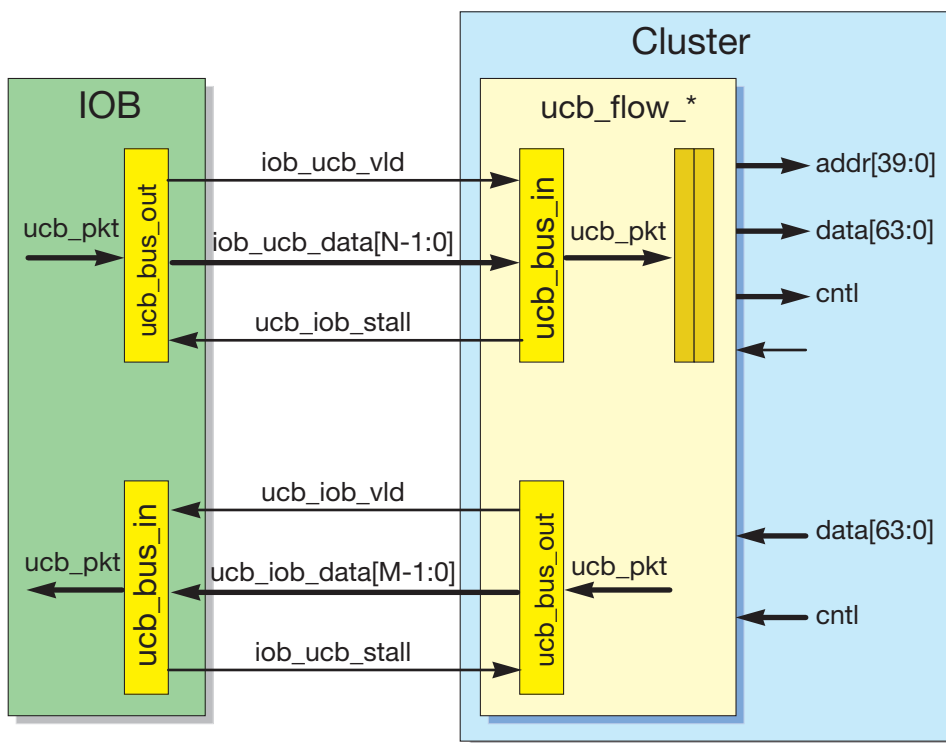

FIGURE 5-2 IOB UCB Interface to and From the Cluster

5.1.2.1 UCB Request and Acknowledge Packets

The UCB request or acknowledge (ACK) packet can have various widths – 64-bits, 128-bits, or 192-bits. TABLE 5-2 defines the UCB request or acknowledge packet format.

TABLE 5-2 UCB Request/Acknowledge Packet format

Bits	191:128	127:64	63:55	54:15	14:12	11:10	9:4	3:0
Description	Extended Data[63:0]	Data [63:0]	Reserved	Address [39:0]	Size	Buffer ID	Thread ID	Packet Type

TABLE 5-3 defines the UCB request or acknowledge packet types.

TABLE 5-3 UCB Request/ACK Packet Types

Description	Packet Type Value (Binary)
UCB_READ_NACK	0000
UCB_READ_ACK	0001
UCB_WRITE_ACK	0010
UCB_IFILL_ACK	0011
UCB_READ_REQ	0100
UCB_WRITE_REQ	0101
UCB_IFILL_REQ	0110
UCB_IFILL_NACK	0111

There is no write NACK as writes to invalid addresses are dropped. Some packet types have data (payload) while others are without data (no payload).

TABLE 5-4 defines the UCB data size parameters.

TABLE 5-4 UCB Data Size

Description	Size Value (Binary)
UCB_SIZE_1B	000
UCB_SIZE_2B	001
UCB_SIZE_4B	010
UCB_SIZE_8B	011
UCB_SIZE_16B	111

The buffer ID is 00 when the master is CPU and the ID is 01 when the master is TAP. The thread ID has two parts – CPU ID (3-bits) and Thread ID within CPU (2-bits).

5.1.2.2 UCB Interrupt Packet

The UCB interrupt packet has a fixed width of 64-bits. [TABLE 5-5](#) describes the UCB interrupt packet format.

TABLE 5-5 UCB Interrupt Packet Format

Bits	63:57	56:51	50:19	18:10	9:4	3:0
Description	Reserved	Vector	Reserved	Device ID	Thread ID	Packet Type

[TABLE 5-6](#) defines the UCB interrupt packet types.

TABLE 5-6 UCB Interrupt Packet Types

Description	Packet Type Value (Binary)	Comment
UCB_INT	1000	
UCB_INT_VEC	1100	IOB Internal Use Only
UCB_RESET_VEC	1101	IOB Internal Use Only
UCB_IDLE_VEC	1110	IOB Internal Use Only
UCB_RESUME_VEC	1111	IOB Internal Use Only

5.1.2.3 UCB Interface Packet Example

The UCB interface packet without payload has width of 64-bits. If the physical interface is 8-bits, it will take 8 cycles (without a stall) to send the packet. The first data sent (D0) is bits 7 to 0, the second data sent (D1) is bits 15 to 8, and so on.

[TABLE 5-7](#) shows the UCB no payload packet (64-bit) over an 8-bit interface without stalls.

TABLE 5-7 UCB No Payload Over an 8-Bit Interface Without Stalls

iob_ucb_vld	0	1	1	1	1	1	1	1	1	0
iob_ucb_data[7:0]	X	D0	D1	D2	D3	D4	D5	D6	D7	X
ucb_iob_stall	0	0	0	0	0	0	0	0	0	0

TABLE 5-8 shows the UCB no payload packet (64-bit) over an 8-bit interface with stalls.

TABLE 5-8 UCB No Payload Over an 8-Bit Interface With Stalls

iob_ucb_vid	0	1	1	1	1	1	1	1	1	1	1	1	0
iob_ucb_data[7:0]	X	D0	D1	D2	D2	D2	D3	D3	D4	D5	D6	D7	X
ucb_iob_stall	0	0	1	1	1	0	0	0	0	0	0	0	0

5.1.3 IOB Address Map

Refer to *UltraSPARC T1 Supplement to UltraSPARC Architecture 2005 Specification* for descriptions of the detailed addresses of the registers and bit levels. TABLE 5-9 describes the high-level IOB address map for the address block level.

TABLE 5-9 IOB Address Map

PA[39:32] (Hex)	Destination	Description
0x00 - 0x7F	DRAM Memory	TAP only - CCX forward request
0x80	JBI PIO	JBI CSRs, J-Bus 8MB Non-Cached & Fake DMA spaces
0x81 - 0x95	Reserved	
0x96	CTU	
0x97	DRAM	DRAM CSRs, PA[12] = 0 for DRAM02, PA[12] = 1 for DRAM13
0x98	IOB_MAN	IOB Management CSRs
0x99	TAP	TAP CSRs
0x9A - 0x9D	Reserved	
0x9E	CPU ASI	TAP Only - CCX forward request
0x9F	IOB_INT	IOB Mondo Interrupt CSRs
0xA0 - 0xBF	L2 CSRs	TAP Only - CCX forward request
0XC0 - 0xFE	JBI PIO	J-Bus 64 GB Non-Cached Spaces
0xFF	JBI SSI	SSI CSRs and Boot PROM

5.1.4 IOB Block Diagram

FIGURE 5-3 shows the IOB internal block diagram. The PCX requests from the CPU are processed by a block called the CPU to I/O (c2i) and it generates UCB requests to the various blocks. UCB requests from various blocks are processed by a block called I/O to CPU (i2c) which then generates a CPX packet. Internal control/status registers (CSRs) are controlled by the CSR block. The debug block takes data from L2-cache and sends it to debug port A (an external port) and to debug port B (to the JBI).

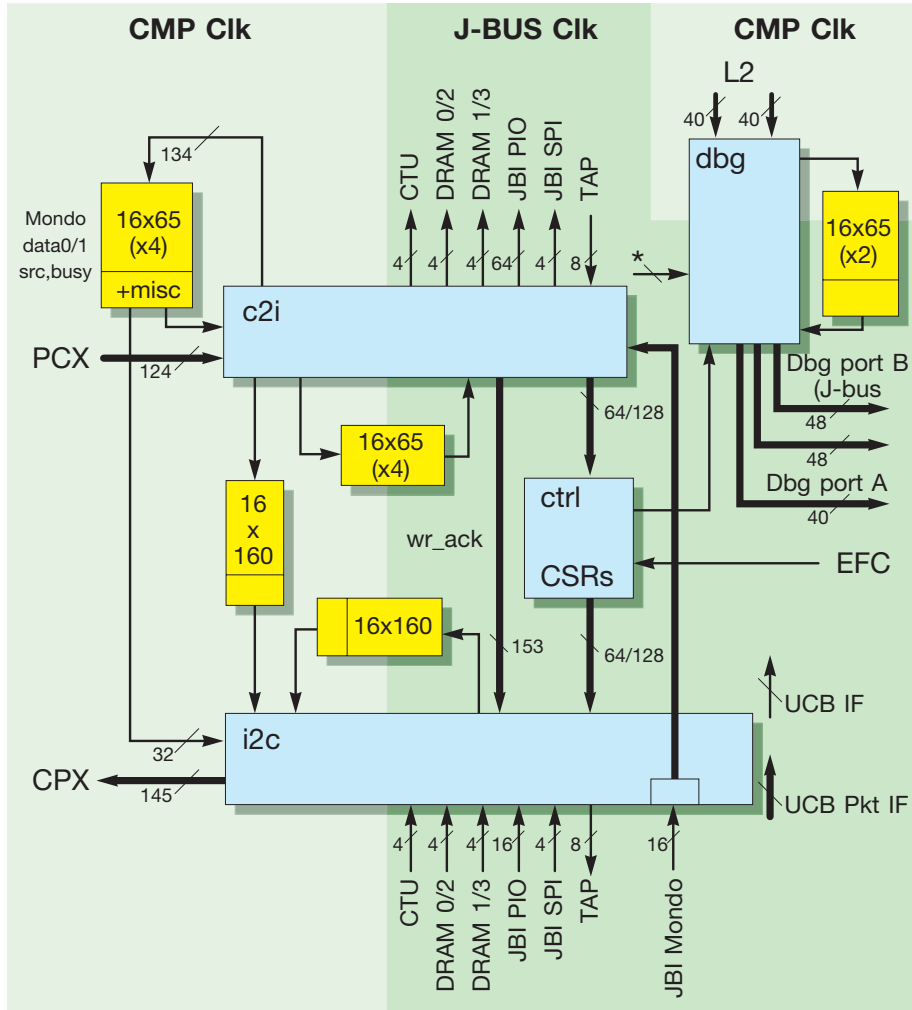

FIGURE 5-3 IOB Internal Block Diagram

5.1.5 IOB Transactions

This section describes the various transactions processed by the IOB.

- UCB Reads:
 - LOAD_RQ packet received by the c2i
 - Map/decode address to the destination port
 - Translates to the UCB packet format and sends UCB_READ_REQ over the UCB
 - UCB_READ_ACK/_NACK received by i2c
 - Translates to the CPX packet format and sends to CPU
- UCB Writes:
 - STORE_RQ packet received by the c2i
 - Map addresses to the destination port
 - Translates to the UCB packet format and sends UCB_WRITE_REQ over the UCB
 - Send write ACK (STORE_ACK) directly to the i2c
 - Sends STORE_ACK packet to the CPX
- IOB_MAN (IOB Management) CSR Accesses:
 - Similar to UCB Reads/Writes, except the UCB request packet is routed to the iobdg_ctrl
 - CSRs (except J_INT_BUSY/DATA0/DATA1) are implemented in the iobdg_ctrl
 - UCB ACK packet sent to the i2c, translated, and sent on to the CPX
- IOB_INT CSR Accesses:
 - J_INT_BUSY/DATA0/DATA1 CSRs are implemented in the register file in the c2i
 - Read/Write ACKS sent to the i2c (by way of the int_buf register file) and sent on to the CPX
- TAP Reads/Writes:
 - TAP mastered requests are similar to the UCB Read/Writes
 - Requests to the TAP CSRs are bounced through the iobdg_ctrl to the i2c for IOB->TAP UCB
 - TAP requests to memory, L2-cache CSRs, and CPU ASIs, are bounced through iobdg_ctrl on to i2c and issued as a forward request to CPX. ACK returns on the PCX.

5.1.6 IOB Interrupts

This section describes the various interrupts that are handled by the IOB.

- UCB Signalled Interrupts (Request Type = UCB_INT)
 - Only two LSBs of the DEV ID are used
 - Error Interrupt (Dev_ID = 1)
 - SSI EXT_INT_L (Dev_ID = 2)
 - Signalled on the UCB interface to the i2c
 - Looks up Mask status in the INT_CTL[Dev_ID], the CPU ID, and the vector in the INT_MAN[Dev_ID] CSR
 - Generate CPX interrupt packets and sends them to the CPU
- Software Generated Interrupts (INT_VEC_DIS CSR)
 - Writable by the CPU or the TAP
 - Sends reset, interrupt, idle, and resume signals to the selected thread
 - Generates UCB interrupt packets in the iobdg_ctrl
 - Translates to the CPX interrupt packet format in the i2c and sends them to the CPU
- J-Bus Mondo Interrupts
 - JBI sends mondo interrupt packet to the i2c
 - Accumulate packet interrupts sent to the target/src/data0/data1
 - If J_INT_BUSY[target] CSR BUSY = 0
 - i. Send ACK to the JBI
 - ii. Send target/src/data0/data1 to the c2i
 - iii. Stores source in J_INT_BUSY[target], data0/1 in J_INT_DATA0/1[target] and set J_INT_BUSY[target] BUSY
 - iv. Generates an CPX interrupt packet to the target using J_INT_VEC CSR and send
 - If J_INT_BUSY[target] CSR BUSY = 1
 - i. Send NACK to the JBI
 - ii. Source will re-issue the INTERRUPT on the J-BUS

- Mondo Interrupt Handling
 - Mondo interrupt CSRs:
 - i. J_INT_VEC – specifies interrupt vector for the CPX Int in order to target thread
 - ii. J_INT_BUSY (count 32) – source and BUSY for each target thread
 - iii. J_INT_DATA0 (count 32) – mondo data 0 for each target thread
 - iv. J_INT_DATA1 (count 32) – mondo data 1 for each target thread
 - v. J_INT_ABUSY, J_INT_ADATA0, J_INT_ADATA1 – aliases to J_INT_BUSY, J_INT_DATA0, J_INT_DATA1 for the current thread
 - The interrupt handler must clear the BUSY bit in J_INT_BUSY[target] to allow future mondo interrupts to that thread

5.1.7 IOB Miscellaneous Functionality

- Launches one thread after reset
 - Sends resume interrupt to thread 0 in the lowest available core (the EFC sends the available cores information)
 - RSET_STAT CSR shows the RO and RW status for: POR, FREQ, and WRM
- Software Visibility for Efuse Data
 - Serial data shifted in after a power-on reset (POR)
 - CORE_AVAIL
 - PROC_SER_NUM
 - IOB_EFUSE – contains parity check results from the EFC (If non-zero, the chip is suspect with a potentially bad CORE_AVAIL or a memory array redundancy)
- Power Management - Thermal Sensor
 - Sends an idle/resume interrupt to threads specified in the TM_STAT_CTL mask

5.1.8 IOB Errors

- Accesses to non-existent I/O addresses (address map reserved)
 - Drops I/O writes
 - Sends NACK for the I/O reads
- IOB forwards NACKs received from the other blocks
- IOB forwards error interrupts signalled by the other blocks

5.1.9 Debug Ports

Debug ports provide on chip support for logic analyzer data capture. The visibility port inputs are:

- L2 visibility ports (2 x 40-bits @ CMP clock) – these are pre-filtered in the CPU clock domain for bandwidth.
- IOB visibility ports (J-Bus clock): you can select the IOB UCB port to monitor with raw valid/stall or decoded qualified-valid qualifiers.

The output debug ports have separate mux select and filtering on each port. There are two debug ports:

- Debug port A - dedicated debug pins (40-bits @ J-Bus clock)
- Debug port B - J-Bus port (2 x 48-bits @ J-Bus clock)
 - 16-bytes data return to a non-existent module (AID 2)

5.2 I/O Bridge Signal List

TABLE 5-10 describes the I/O Signals for OpenSPARC T1 processor's IOB.

TABLE 5-10 I/O Bridge I/O Signal List

Signal Name	I/O	Source/Destination	Description
clk_iob_cmp_cken	In	CTU	
clk_iob_data[3:0]	In	CTU	
clk_iob_jbus_cken	In	CTU	
clk_iob_stall	In	CTU	
clk_iob_vld	In	CTU	
clspine_iob_resetstat[3:0]	In		
clspine_iob_resetstat_wr	In		
clspine_jbus_rx_sync	In		RX synchronous
clspine_jbus_tx_sync	In		TX synchronous
cmp_adbginit_l	In	CTU	Asynchronous reset
cmp_arst_l	In	CTU	Asynchronous reset
cmp_gclk	In	CTU	Clock
cmp_gdbginit_l	In	CTU	Synchronous reset

TABLE 5-10 I/O Bridge I/O Signal List (Continued)

Signal Name	I/O	Source/Destination	Description
cmp_grst_l	In	CTU	Synchronous reset
cpx_iob_grant_cx2[7:0]	In	CCX:CPX	CPX grant
ctu_iob_wake_thr	In	CTU	
ctu_tst_macrotest	In	CTU	
ctu_tst_pre_grst_l	In	CTU	
ctu_tst_scan_disable	In	CTU	
ctu_tst_scanmode	In	CTU	
ctu_tst_short_chain	In	CTU	
dbg_en_01	In		
dbg_en_23	In		
dram02_iob_data[3:0]	In	DRAM	UCB data
dram02_iob_stall	In	DRAM	UCB stall
dram02_iob_vld	In	DRAM	UCB valid
dram13_iob_data[3:0]	In	DRAM	UCB data
dram13_iob_stall	In	DRAM	UCB stall
dram13_iob_vld	In	DRAM	UCB valid
efc_iob_coreavail_dshift	In	EFC	
efc_iob_fuse_data	In	EFC	
efc_iob_fusestat_dshift	In	EFC	
efc_iob_serenum0_dshift	In	EFC	
efc_iob_serenum1_dshift	In	EFC	
efc_iob_serenum2_dshift	In	EFC	
global_shift_enable	In	CTU	
io_temp_trig	In	PADS	
io_trigin	In	PADS	
jbi_iob_mondo_data[7:0]	In	JBI	UCB data
jbi_iob_mondo_vld	In	JBI	UCB valid
jbi_iob_pio_data[15:0]	In	JBI	UCB data
jbi_iob_pio_stall	In	JBI	UCB stall
jbi_iob_pio_vld	In	JBI	UCB valid

TABLE 5-10 I/O Bridge I/O Signal List (Continued)

Signal Name	I/O	Source/Destination	Description
jbi_iob_spi_data[3:0]	In	JBI	UCB data
jbi_iob_spi_stall	In	JBI	UCB stall
jbi_iob_spi_vld	In	JBI	UCB valid
jbus_adbginit_1	In	CTU	Asynchronous reset
jbus_arst_1	In	CTU	Asynchronous reset
jbus_gclk	In	CTU	Clock
jbus_gdbginit_1	In	CTU	Synchronous reset
jbus_grst_1	In	CTU	Synchronous reset
l2_dbgbus_01[39:0]	In	L2	Debug bus
l2_dbgbus_23[39:0]	In	L2	Debug bus
pcx_iob_data_px2[123:0]	In	CCX:PCX	PCX packet
pcx_iob_data_rdy_px2	In	CCX:PCX	PCX data ready
tap_iob_data[7:0]	In	CTU:TAP	UCB data
tap_iob_stall	In	CTU:TAP	UCB stall
tap_iob_vld	In	CTU:TAP	UCB valid
efc_iob_fuse_clk1	In	EFC	
iob_scanin	In	DFT	Scan in
iob_clk_l2_tr	Out	CTU	Debug trigger
iob_clk_tr	Out	CTU	Debug trigger
iob_cpx_data_ca[144:0]	Out	CCX:CPX	CPX packet
iob_cpx_req_cq[7:0]	Out	CCX:CPX	CPX request
iob_ctu_coreavail[7:0]	Out	CTU	
iob_io_dbg_ck_n[2:0]	Out	PADS	Debug clock N
iob_io_dbg_ck_p[2:0]	Out	PADS	Debug clock P
iob_io_dbg_data[39:0]	Out	PADS	Debug bus
iob_io_dbg_en	Out	PADS	Debug enable
iob_jbi_dbg_hi_data[47:0]	Out	JBI	Debug data high
iob_jbi_dbg_hi_vld	Out	JBI	Debug data high valid
iob_jbi_dbg_lo_data[47:0]	Out	JBI	Debug data low
iob_jbi_dbg_lo_vld	Out	JBI	Debug data high valid

TABLE 5-10 I/O Bridge I/O Signal List (*Continued*)

Signal Name	I/O	Source/Destination	Description
iob_jbi_mondo_ack	Out	JBI	MONDO ACK
iob_jbi_mondo_nack	Out	JBI	MONDO negative ACK
iob_pcx_stall_pq	Out	CCX:PCX	PCX stall
iob_clk_data[3:0]	Out	CTU:CLK	UCB data
iob_clk_stall	Out	CTU:CLK	UCB stall
iob_clk_vld	Out	CTU:CLK	UCB valid
iob_dram02_data[3:0]	Out	DRAM	DRAM data
iob_dram02_stall	Out	DRAM	DRAM stall
iob_dram02_vld	Out	DRAM	DRAM valid
iob_dram13_data[3:0]	Out	DRAM	DRAM data
iob_dram13_stall	Out	DRAM	DRAM stall
iob_dram13_vld	Out	DRAM	DRAM valid
iob_jbi_pio_data[63:0]	Out	JBI	PIO data
iob_jbi_pio_stall	Out	JBI	PIO stall
iob_jbi_pio_vld	Out	JBI	PIO valid
iob_jbi_spi_data[3:0]	Out	JBI	JBI UCB data
iob_jbi_spi_stall	Out	JBI	JBI UCB stall
iob_jbi_spi_vld	Out	JBI	JBI UCB valid
iob_tap_data[7:0]	Out	CTU:TAP	UCB data
iob_tap_stall	Out	CTU:TAP	UCB stall
iob_tap_vld	Out	CTU:TAP	UCB valid
iob_scanout	Out	DFT	Scan out

J-Bus Interface

This chapter contains the following topics about the J-Bus interface (JBI) functional block:

- [Section 6.1, “Functional Description” on page 6-1](#)
- [Section 6.2, “I/O Signal list” on page 6-8](#)

6.1 Functional Description

For a detailed description on the external J-Bus interface, refer to *OpenSPARC T1 Processor External Interface Specification*. The OpenSPARC T1 J-Bus interface (JBI) block generates J-Bus transactions and responds to external J-Bus transactions.

The JBI block:

- Interfaces with following blocks in an OpenSPARC T1 processor:
 - L2-cache (scbuf and sctag) to read and write data to L2-cache
 - I/O Bridge (IOB) - for programmed input/output (PIO), interrupts, and debug port
 - J-Bus I/O pads
- Most of the JBI sub-blocks use the J-Bus clock, and remaining part runs at the CPU core clock or *cmp clk*. The data transfer between the two clock domains is by way of queues within the two clock domains, these are the Request header queues and the Return data queues. The interface to the L2-cache is through the direct memory access (DMA) reads and DMA writes.
- The IOB debug port data is stored in the debug FIFOs and then it is sent out to the external J-Bus.
- IOB PIO requests are stored in the PIO queue and the return data is stored in the PIO return queue. Similarly, there is an interrupt queue and an interrupt ACK/NACK queues in the JBI in order to interface to the IOB.

- There are only two sub-blocks in the JBI (J-Bus parser and J-Bus transaction issue) specific to J-Bus. All of the other blocks are J-Bus independent. J-Bus independent blocks can be used for any other external bus interface implementation.

FIGURE 6-1 displays the JBI block diagram.

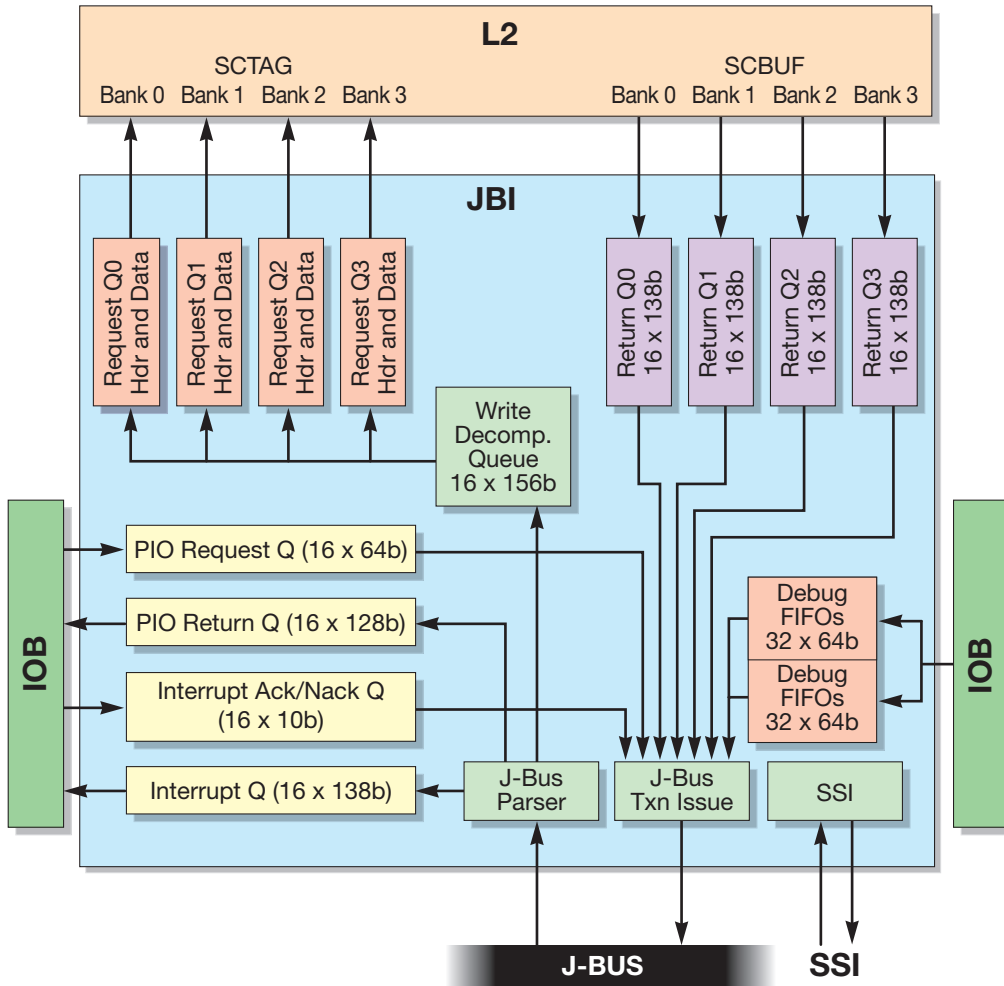

FIGURE 6-1 JBI Functional Block Diagram

The following sub-sections describe the various JBI transactions and interfaces from the JBI to the other functional blocks.

6.1.1 J-Bus Requests to the L2-Cache

There are two types of requests from J-Bus to L2 – read and write.

6.1.1.1 Write Requests to the L2-Cache

DMA write request from J-Bus is parsed by J-Bus parser and then it passes the information to the Write Decomposition Queue, which will then send Request Header and Data to sctag of L2-cache.

- The following types of writes are supported (refer to the *OpenSPARC T1 External Interface Specification* for details of the transaction types):
 1. WriteInvalidate (WRI), WriteInvalidateSelf (WRIS), NonCachedWriteCompressible (NCBWR) are treated as 64-byte writes
 2. NCWR is treated as 8-byte write
 3. WriteMerge (WRM):
 - WRM is similar to WRI but with 64-bit Byte enables, supporting 0 to 64-byte writes.
 - Multiple 8-byte write requests (WR8) to the L2-cache
 - Write decomposition
 - WRM is broken into 8-byte write requests (WR8) and sent to the L2-cache at the head of the write decomposition queue (WDQ)
 - Number of requests is dependent on the WRM byte enable pattern
 - Each WR8 request writes 1 to 8 contiguous bytes
 - If a run of contiguous bytes crosses an 8-byte address boundary, two WR8s are generated
 - A WRM transaction can generate up to 32 WR8s to the L2-cache
 - Writes to the L2-cache may observe strict ordering with respect to the other writes to the L2-cache (software programmable)

6.1.1.2 Read Requests to the L2-Cache

A DMA read request from the J-Bus is parsed by the J-Bus parser and then the information is passed to the write decomposition queue (WDQ), which will then send the request header to the sctag of the L2-cache. Data returned from the L2-cache sbuf is then passed from the return queues to the J-Bus transaction issue, and then to the J-Bus.

- Type of reads supported:
 - ReadToDiscard (RDD), ReadToShare (RDS), ReadToShareAlways (RDSA), NonCachedBlockRead (NCBRD) translates to 64-byte RDDs to the L2-cache
 - NonCachedRead (NCRD) translates to 8-byte RDD to the L2-cache
 - There is a maximum of 4 outstanding reads to each L2-cache bank
- Reads to the L2-cache may observe strict ordering with respect to writes to the L2-cache (software programmable)

6.1.1.3 Flow Control

WDQ gives backward pressure to the J-Bus when the programmable high watermark has been reached. Credit based flow control exists between the JBI and the L2-cache, arising from the L2-cache's two-entry snoop input buffer and the four-entry RDMA write buffer.

6.1.2 I/O Buffer Requests to the J-Bus

Write requests (NCWR) can be 1, 2, 4, or 8-byte writes and those writes are aligned to size. Write request comes from the I/O buffer (IOB), gets stored in the PIO request queue, and then goes out on the J-Bus.

Read requests comes from IOB, gets stored in the PIO request queue, and then goes out on the J-Bus. The data read from J-Bus is then parsed by J-Bus parser, and then the data is stored in the PIO return queue which is sent to the IOB.

The Read transactions (NCRD) can be 1, 2, 4, 8, 16-byte reads and are aligned to size. There is a maximum support for 1 to 4 pending reads to the J-Bus (software programmable). Read returns to the IOB may observe strict ordering with respect to the writes to the L2-cache (software programmable).

6.1.3 J-Bus Interrupt Requests to the IOB

- A J-Bus interrupt in the mondo vector format is received by the J-Bus parser and then it is stored in the interrupt queue before being sent to the IOB.
- A modified mondo interrupt transaction is where only the first data cycle is forwarded to the CPU.
- The mondo interrupt queue is maximally sized to 16 entries, and there is no flow control on queue.
- Interrupts to the IOB may observe strict ordering with respect to the writes to the L2-cache (software programmable).
- An interrupt ACK/NACK received from the IOB is first stored in the interrupt ACK/NACK queue, and then it is sent out on the J-Bus.

6.1.4 J-Bus Interface Details

The J-Bus interface has the following characteristics:

- JBI Requests the J-Bus as agent 0
- Masters transaction using agent ID 0 to 3
- 16 transaction IDs (TIDs) assigned in the least recently used order
- A read TID becomes available when the read data is returned
- A write TID is never marked *unavailable*
- Responds to the addresses corresponding to agent ID 0 to 3
- External J-Bus arbitration:
 - Adheres to the J-Bus arbitration protocol
 - May arbitrate to maximize its time as the default owner, in order to opportunistically drive the debug port data even when it has nothing to issue (software controlled)
 - JBI starts up in multi-segment arb mode, which can be change by way of software
- Flow control - address OK (AOK) and data OK (DOK)
 - Uses only AOK-off to flow control the J-Bus when WDQ reaches its high watermark
 - DOK-off is not used for flow control
 - Follows J-Bus protocol when other agents assert their AOKs/DOKs

6.1.5 Debug Port to the J-Bus

- There are two debug first-in/first-outs (FIFOs), each with 32 entries
- Programmable to fill and dump from one or both FIFOs. If both FIFOs are programmed, then each FIFO is alternately filled, but they are dumped both in parallel, thus using half as many cycles.
- Arbitration models for using the J-Bus to report debug data include:
 - Default - when the J-Bus is idle, and the JBI has no other transactions available to issue on to the J-Bus, the JBI opportunistically dumps debug data if it is the default owner
 - DATA_ARB - JBI will arbitrate (arb) whenever the FIFOs are higher than the low watermark, and the JBI is not the bus owner
 - AGGR_ARB - JBI arbs whenever it does not own the bus, so the bus behavior does not change based on the quantity of the debug output
- Debug data appears on the J-Bus as a Read16 return cycle to the AID4 with debug data payload on J_AD[127:0]
- Fake DMA range (0x80_1000_0000 to 0x80_FFFF_FFFF) is used for the debug data
- Error injection is supported in outbound and inbound J-Bus traffic
- BI debug info, when enabled, is placed in the transaction headers (the JBI queues info in the upper 64 bits of the AD)

6.1.6 J-Bus Internal Arbitration

- There are seven agents for internal arbitration:
 - Four read return queues
 - PIO request queues
 - Mondo interrupt ACK/NACK queues
 - Debug FIFO
- In the default arbitration, the debug FIFO has the lowest priority, and there is round-robin arbitration between the other six agents
- Until the FIFO is flushed, the debug FIFO has the highest priority when the HI_WATER or MAX_WAIT limits are reached

6.1.7 Error Handling in JBI

- There are 19 different fatal and not-correctable errors, each with a log enable, signal enable, error detected bit, and error overflow detected bit. (Refer to the *UltraSPARC T1 Supplement to UltraSPARC Architecture 2005 Specification* for details on programming control bits and reading status registers.)
- J-Bus snapshot registers contain address, data, control, parity bits.
- J-Bus requests to non-existent memory causes a read to address 0 before the JBI issues an error cycle on the J-Bus.
- Fatal error asserts DOK-on for 4 cycles, which instructs the external J-Bus to PCI-Express ASIC to perform a warm reset.

6.1.8 Performance Counters

- There are two performance counters in the JBI, which are 31-bits wide each.
- The software can select one of the 12 events to be counted:
 - J-Bus cycles
 - DMA read transactions (inbound)
 - Total DMA read latency
 - DMA write transactions
 - DMA WR8 transactions
 - Ordering waits (number of jbi->l2 queues blocked each cycle)
 - PIO read transactions
 - Total PIO read latency
 - PIO write transactions
 - AOK off or DOK off seen
 - AOK off seen
 - DOK off seen

6.2 I/O Signal list

TABLE 6-1 lists the I/O Signals for the OpenSPARC T1 JBI block.

TABLE 6-1 JBI I/O Signal List

Signal Name	I/O	Source/ Destination	Description
cmp_gclk	In	CTU	CMP clock.
cmp_arst_l	In	CTU	CMP clock domain async reset.
cmp_grst_l	In	CTU	CMP clock domain reset.
jbus_gclk	In	CTU	J-Bus clock.
jbus_arst_l	In	CTU	J-Bus clock domain async reset.
jbus_grst_l	In	CTU	J-Bus clock domain reset.
ctu_jbi_ssiclk	In	CTU	J-Bus clk divided by 4
ctu_jbi_tx_en	In	CTU	CMP to JBI clock domain crossing synchronization pulse.
ctu_jbi_rx_en	In	CTU	JBI to CMP clock domain crossing synchronization pulse.
ctu_jbi_fst_rst_l	In	CTU	Fast reset for capturing port present bits (J_RST_L + 1).
clk_jbi_jbus_cken	In	CTU	Jbi clock enable.
clk_jbi_cmp_cken	In	CTU	Cmp clock enable.
global_shift_enable	In	CTU	Scan shift enable signal.
ctu_tst_scanmode	In	CTU	Scan mode.
ctu_tst_pre_grst_l	In	CTU	
ctu_tst_scan_disable	In	CTU	
ctu_tst_macrotest	In	CTU	
ctu_tst_short_chain	In	CTU	
ddr3_jbi_scanin18	In	DFT	
jbusr_jbi_si	In	DFT	
sctag0_jbi_iq_dequeue	In	SCTAG0	SCTag is unloading a request from its 2 request queue.
sctag0_jbi_wib_dequeue	In	SCTAG0	Write invalidate buffer (size=4) is being unloaded.
scbuf0_jbi_data[31:0]	In	SCBUF0	Return data
scbuf0_jbi_ctag_vld	In	SCBUF0	Header cycle of a new response packet.
scbuf0_jbi_ue_err	In	SCBUF0	Current data cycle has a uncorrectable error.

TABLE 6-1 JBI I/O Signal List (*Continued*)

Signal Name	I/O	Source/ Destination	Description
sctag0_jbi_por_req_buf	In	SCTAG0	Request for DOK_FATAL.
sctag1_jbi_iq_dequeue	In	SCTAG1	SCTag is unloading a request from its 2 request queue.
sctag1_jbi_wib_dequeue	In	SCTAG1	Write invalidate buffer (size=4) is being unloaded.
scbuf1_jbi_data[31:0]	In	SCBUF1	Return data
scbuf1_jbi_ctag_vld	In	SCBUF1	Header cycle of a new response packet.
scbuf1_jbi_ue_err	In	SCBUF1	Current data cycle has a uncorrectable error.
sctag1_jbi_por_req_buf	In	SCTAG1	Request for DOK_FATAL.
sctag2_jbi_iq_dequeue	In	SCTAG2	SCTag is unloading a request from its 2 request queue.
sctag2_jbi_wib_dequeue	In	SCTAG2	Write invalidate buffer (size=4) is being unloaded.
scbuf2_jbi_data[31:0]	In	SCBUF2	Return data
scbuf2_jbi_ctag_vld	In	SCBUF2	Header cycle of a new response packet.
scbuf2_jbi_ue_err	In	SCBUF2	Current data cycle has a uncorrectable error.
sctag2_jbi_por_req_buf	In	SCTAG2	Request for DOK_FATAL.
sctag3_jbi_iq_dequeue	In	SCTAG3	SCTag is unloading a request from its 2 request queue.
sctag3_jbi_wib_dequeue	In	SCTAG3	Write invalidate buffer (size=4) is being unloaded.
scbuf3_jbi_data[31:0]	In	SCBUF3	Return data
scbuf3_jbi_ctag_vld	In	SCBUF3	Header cycle of a new response packet.
scbuf3_jbi_ue_err	In	SCBUF3	Current data cycle has a uncorrectable error.
sctag3_jbi_por_req_buf	In	SCTAG3	Request for DOK_FATAL.
iob_jbi_pio_stall	In	IOB	PIO stall
iob_jbi_pio_vld	In	IOB	PIO valid
iob_jbi_pio_data[63:0]	In	IOB	PIO data
iob_jbi_mondo_ack	In	IOB	Mondo acknowledgement
iob_jbi_mondo_nack	In	IOB	Mondo negative acknowledgement
io_jbi_ssi_miso	In	PADS	SSI Master in slave out from pad.
io_jbi_ext_int_l	In	PADS	External interrupt
iob_jbi_spi_vld	In	IOB	Valid packet from IOB.
iob_jbi_spi_data[3:0]	In	IOB	Packet data from IOB.
iob_jbi_spi_stall	In	IOB	Flow control to stop data.
io_jbi_j_req4_in_l	In	PADS	J-Bus request. 4 input

TABLE 6-1 JBI I/O Signal List (*Continued*)

Signal Name	I/O	Source/ Destination	Description
io_jbi_j_req5_in_1	In	PADS	J-Bus request. 5 input
io_jbi_j_adtype[7:0]	In	PADS	J-Bus packet type
io_jbi_j_ad[127:0]	In	PADS	J-Bus address/data bus
io_jbi_j_pack4[2:0]	In	PADS	J-Bus ACK 4
io_jbi_j_pack5[2:0]	In	PADS	J-Bus ACK 5
io_jbi_j_adp[3:0]	In	PADS	J-Bus parity for AD bus
io_jbi_j_par	In	PADS	J-Bus parity for request/PACK
iob_jbi_dbg_hi_data[47:0]	In	IOB	Debug data high
iob_jbi_dbg_hi_vld	In	IOB	Debug data high valid
iob_jbi_dbg_lo_data[47:0]	In	IOB	Debug data low
iob_jbi_dbg_lo_vld	In	IOB	Debug data low valid
jbi_ddr3_scanout18	Out	DFT	Scan out
jbi_clk_tr	Out	CTU	Debug_trigger.
jbi_jbusr_so	Out	DFT	Scan out
jbi_jbusr_se	Out	DFT	Scan enable
jbi_sctag0_req[31:0]	Out	SCTAG0	L2-cache request
jbi_scbuf0_ecc[6:0]	Out	SCBUF0	
jbi_sctag0_req_vld	Out	SCTAG0	Next cycle will be header of a new request packet.
jbi_sctag1_req[31:0]	Out	SCTAG1	L2-cache request
jbi_scbuf1_ecc[6:0]	Out	SCBUF1	
jbi_sctag1_req_vld	Out	SCTAG1	Next cycle will be header of a new request packet.
jbi_sctag2_req[31:0]	Out	SCTAG2	L2-cache request
jbi_scbuf2_ecc[6:0]	Out	SCBUF2	
jbi_sctag2_req_vld	Out	SCTAG2	Next cycle will be header of a new request packet.
jbi_sctag3_req[31:0]	Out	SCTAG3	L2-cache request
jbi_scbuf3_ecc[6:0]	Out	SCBUF3	
jbi_sctag3_req_vld	Out	SCTAG3	Next cycle will be Header of a new request packet.
jbi_iob_pio_vld	Out	IOB	PIO valid
jbi_iob_pio_data[15:0]	Out	IOB	PIO data
jbi_iob_pio_stall	Out	IOB	PIO stall

TABLE 6-1 JBI I/O Signal List (*Continued*)

Signal Name	I/O	Source/ Destination	Description
jbi_iob_mondo_vld	Out	IOB	MONDO valid
jbi_iob_mondo_data[7:0]	Out	IOB	MONDO data
jbi_io_ssi_mosi	Out	PADS	Master out slave in to pad.
jbi_io_ssi_sck	Out	PADS	Serial clock to pad.
jbi_iob_spi_vld	Out	IOB	Valid packet from UCB.
jbi_iob_spi_data[3:0]	Out	IOB	Packet data from UCB.
jbi_iob_spi_stall	Out	IOB	Flow control to stop data.
jbi_io_j_req0_out_l	Out	PADS	J-Bus request 0
jbi_io_j_req0_out_en	Out	PADS	J-Bus request 0 enable
jbi_io_j_adtype[7:0]	Out	PADS	J-Bus type
jbi_io_j_adtype_en	Out	PADS	J-Bus type enable
jbi_io_j_ad[127:0]	Out	PADS	J-Bus address/data
jbi_io_j_ad_en[3:0]	Out	PADS	J-Bus address/data enable
jbi_io_j_pack0[2:0]	Out	PADS	J-Bus ACK. 0
jbi_io_j_pack0_en	Out	PADS	J-Bus ACK. 0 enable
jbi_io_j_pack1[2:0]	Out	PADS	J-Bus ACK. 1
jbi_io_j_pack1_en	Out	PADS	J-Bus ACK. 1 enable
jbi_io_j_adp[3:0]	Out	PADS	J-Bus address/data Parity
jbi_io_j_adp_en	Out	PADS	J-Bus address/data parity enable
jbi_io_config_dtl[1:0]	Out	PADS	J-Bus I/O DTL configuration

Floating-Point Unit

This chapter describes the following topics:

- [Section 7.1, “Functional Description” on page 7-1](#)
- [Section 7.2, “I/O Signal list” on page 7-15](#)

7.1 Functional Description

The OpenSPARC T1 floating-point unit (FPU) has the following features and supports the following functions:

- The FPU implements the SPARC V9 floating-point instruction set with the following exceptions:
 - Does not implement these instructions – FSQRT(s,d), and all quad precision instructions
 - Move-type instructions executed by the SPARC core floating-point frontend unit (FFU): FMOV(s,d), FMOV(s,d)cc, FMOV(s,d)r, FABS(s,d), FNEG(s,d)
 - Loads and stores (the SPARC core FFU executes these operations)
- The FPU does not support the visual instruction set (VIS). (The SPARC core FFU provides limited VIS support.)
- The FPU is a single shared resource on the OpenSPARC T1 processor. Each of the eight SPARC cores may have a maximum of one outstanding FPU instruction. A thread with an outstanding FPU instruction stalls (switches out) while waiting for the FPU result.
- The floating-point register file (FRF) and floating-point state register (FSR) are not physically located within the FPU. The SPARC core FFU owns the register file and FSR. The SPARC core FFU also performs odd/even single precision address handling.
- The FPU complies with the IEEE 754 standard.

- The FPU includes three independent execution pipelines:
 - Floating-point adder (FPA) – adds, subtracts, compares, conversions
 - Floating-point multiplier (FPM) – multiplies
 - Floating-point divider (FPD) – divides
- One instruction per cycle may be issued from the FPU input FIFO queue to one of the three execution pipelines.
- One instruction per cycle may complete and exit the FPU.
- Support for all IEEE 754 floating-point data types (normalized, denormalized, NaN, zero, infinity). A denormalized operand or result will never generate an unfinished_FPop trap to the software. The hardware provides full support for denormalized operands and results.
- IEEE non-standard mode (FSR.ns) is ignored by the FPU.
- The following instruction types are fully pipe-lined and have a fixed latency, independent of operand values – add, subtract, compare, convert between floating-point formats, convert floating-point to integer, convert integer to floating-point.
- The following instruction types are not fully pipe-lined – multiply (fixed latency, independent of operand values), divide (variable latency, dependent on operand values).
- Divide instructions execute in a dedicated datapath and are non-blocking.
- Underflow tininess is detected before rounding. Loss of accuracy is detected when the delivered result value differs from what would have been computed were both the exponent range and precision unbounded (inexact condition).
- A precise exception model is maintained. The OpenSPARC T1 implementation does not require early exception detection/prediction. A given thread stalls (switches out) while waiting for an FPU result.
- The FPU includes three parallel pipelines and these pipelines can simultaneously have instructions at various stages of completion. [FIGURE 7-1](#) displays an FPU block diagram that shows these parallel pipelines.

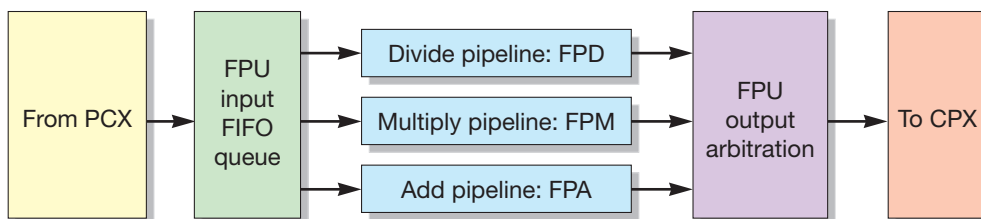

FIGURE 7-1 FPU Functional Block Diagram

TABLE 7-1 OpenSPARC T1 FPU Feature Summary

Feature	OpenSPARC T1 Processor FPU Implementation
ISA	SPARC V9
VIS	Not available
Issue	1
Register file	In FFU
FDIV blocking	No
Full hardware denorm support	Yes
Hardware quad support	No

The following sections provide additional information about the OpenSPARC T1 FPU:

- [Section 7.1.1, “Floating-Point Instructions” on page 7-4](#)
- [Section 7.1.2, “FPU Input FIFO Queue” on page 7-5](#)
- [Section 7.1.3, “FPU Output Arbitration” on page 7-6](#)
- [Section 7.1.4, “Floating-Point Adder” on page 7-6](#)
- [Section 7.1.5, “Floating-Point Multiplier” on page 7-7](#)
- [Section 7.1.6, “Floating-Point Divider” on page 7-8](#)
- [Section 7.1.7, “FPU Power Management” on page 7-9](#)
- [Section 7.1.8, “Floating-Point State Register Exceptions and Traps” on page 7-10](#)

7.1.1 Floating-Point Instructions

TABLE 7-2 describes the floating-point instructions, including the execution latency and the throughput for each instruction.

TABLE 7-2 SPARC V9 Single and Double Precision FPop Instruction Set

Mnemonic	Description	Pipe	Execution Latency	Throughput
FADD(s,d)	Floating-point add	FPA	4	1/1
FSUB(s,d)	Floating-point subtract	FPA	4	1/1
FCMP(s,d)	Floating-point compare	FPA	4	1/1
FCMPE(s,d)	Floating-point compare (exception if unordered)	FPA	4	1/1
F(s,d)TO(d,s)	Convert between floating-point formats	FPA	4	1/1
F(s,d)TOi	Convert floating point to integer	FPA	4	1/1
F(s,d)TOx	Convert floating point to 64-bit integer	FPA	4	1/1
FiTOd	Convert integer to floating point	FPA	4	1/1
FiTOs	Convert integer to floating point	FPA	5	1/1
FxTO(s,d)	Convert 64-bit integer to floating point	FPA	5	1/1
FMUL(s,d)	Floating-point multiply	FPM	7	1/2
FsMULd	Floating-point multiply single to double	FPM	7	1/2
FDIV(s,d)	Floating-point divide	FPD	32 SP, 61 DP (less for zero or denormalized results)	29 SP, 58 DP (less for zero or denormalized results)
FSQRT(s,d)	Floating-point square root	<i>Unimplemented</i>		
FMOV(s,d)	Floating-point move	<i>Executed in the SPARC core FFU</i>		
FMOV(s,d)cc	Move floating-point register if condition is satisfied			
FMOV(s,d)r	Move floating-point register if integer register contents satisfy condition			
FABS(s,d)	Floating-point absolute value			
FNEG(s,d)	Floating-point negate			

7.1.2 FPU Input FIFO Queue

The OpenSPARC FPU input first-in/first-out (FIFO) queue has the following characteristics:

- Contains: 16 entry x 155-bits, 1R/1W ports.
- The input FIFO queue accepts input data from the crossbar. One source operand per cycle is transferred. The crossbar will always provide a two-cycle transfer. Single source instructions produce an invalid transfer on the second cycle.
- A bypass path around the FIFO is provided when the FIFO is empty.
- While a two-source instruction requires two valid transfers, the two transfers are merged into a single 155-bit entry prior updating or bypassing the FIFO.
- For single source instructions, the FPU forces rs1 to zero (within the 155-bit entry) prior to updating or bypassing the FIFO.
- For single precision operands, the unused 32-bit region of the 64-bit source is forced to zero by the FFU. The 32-bits of single precision data is always contained in the upper 32-bits of the 64-bit source.
- One instruction per cycle may be issued from the FIFO queue to one of the three execution pipelines (FPA, FPM, or FPD).
- Prior to updating or bypassing the FIFO, five tag bits are generated per source operand. This creates a 69-bit source operand width (64+5=69). The five tag bits convey information about the zero fraction, the zero exponent, and the all ones exponent.
- Eight FIFO entries are dedicated to the combined FPA/FPM, and eight entries are dedicated to FPD. The FPD has issue priority over FPA/FPM.
- The eight FPD FIFO entries and the eight FPA/FPM entries always issue in FIFO order.
- The 155-bit FIFO entry format:
 - [154:150] – 5-bit ID (CPU and thread)
 - [149:148] – 2-bit round mode
 - [147:146] – 2-bit fcc field
 - [145:138] – 8-bit opcode
 - [137:69] – 69-bit rs1 (includes tag bits)
 - [68:0] – 69-bit rs2 (includes tag bits)

7.1.3 FPU Output Arbitration

The FPA, FPM, and FPD execution pipelines are arbitrated for the single FPU result bus to the crossbar. Only one instruction may complete and exit the FPU per cycle. During this arbitration, the FPD pipeline has priority over the FPA and the FPM pipelines. The FPA and FPM pipelines are prioritized in a round-robin fashion.

If an FPA or FPM execution pipeline is waiting for its result to exit the FPU, the pipeline will stall at the final execution stage. If the final execution stage is not occupied by a valid instruction, instructions within the pipeline will advance, and the input FIFO queue may issue to the pipeline. If the final execution stage is occupied by a valid instruction then each pipeline stage is held.

The input FIFO queue will not advance if the instruction at the head of the FIFO must issue to a pipeline, which at each stage has been held due to a result from that pipeline not exiting the FPU.

7.1.4 Floating-Point Adder

The floating-point adder (FPA) performs addition and subtraction on single and double precision floating-point numbers, conversions between floating point and integer formats, and floating-point compares.

FPA characteristics include:

- The FPA execution datapath is implemented in four pipeline stages (A1, A2, A3, and A4).
- Certain integer conversions to floating-point instructions require a second pass through the final stage (see [TABLE 7-3](#) for details).
- All FPA instructions are fixed latency, and independent of operand values.
- Follows a large exponent difference (LED)/small exponent difference (SED) mantissa datapath organization.
- A post-normalization incremter is used for rounding (*late round* organization).
- NaN source propagation is supported by steering the appropriate NaN source through the datapath to the result. (Refer to the *UltraSPARC Architecture 2005 Specification* for more information.)

TABLE 7-3 FPA Datapath Stages

Stage	LED Action	SED Action
A1	Format input operands Compare fractions	
A2	Align smaller operand to larger operand Invert smaller operand if a logical (effective) subtraction is to be performed	Invert smaller operand if a logical (effective) subtraction is to be performed Compute the intermediate result (A + B)
A3	Compute the intermediate result (A + B)	Leading zero detect
A4	Round FiTOs, FxTOs, FxTOd instructions only	Normalize
A4		Round

7.1.5 Floating-Point Multiplier

Characteristics of the floating-point multiplier (FPM) include:

- The FPM execution datapath is implemented in six pipeline stages (M1 through M6). (See [TABLE 7-4](#) for details of these stages.)
- A two-pass (*double-pump*) implementation is used for all multiply instructions (single and double precision), which produces a latency of seven cycles and a throughput of one instruction every two cycles.
- All FPM instructions are fixed latency and are independent of the operand values.
- A post-normalization incrementer is used for rounding (otherwise known as a *late round* organization).
- NaN source propagation is supported by steering the appropriate NaN source through the datapath to the result. (Refer to the *UltraSPARC Architecture 2005 Specification* for more information.)

TABLE 7-4 FPM Datapath Stages

Stage	Action
M1	Format input operands, booth recoder
M2 – M4	<ul style="list-style-type: none">• Generate partial products using a radix-4 booth algorithm• Accumulate partial products using a Wallace tree configuration• Add the two Wallace tree outputs using a carry-propagate adder
M5	Normalize
M6	Round

7.1.6 Floating-Point Divider

The floating-point divider (FPD) has the following characteristics:

- The floating point divide (FDIV) instructions maximum execution latency is: 32 single precision (SP), and 61 double precision (DP). (Zero or denormalized results have less latency.)
- Normalized results always produce a fixed execution latency of 32 SP, 61 DP.
- Denormalized results produce a variable execution latency of between 9 and 31 for SP, and between 9 and 60 for DP.
- Zero results always produce a fixed execution latency of 7 SP, 7 DP.
- Infinity or QNaN results always produce a fixed execution latency of 32 SP, 61 DP.
- The FPD uses a shift/subtract restoring algorithm generating 1-bit per cycle.
- The FDIV instructions execute in a dedicated datapath and are non-blocking.
- The FPD execution datapath is implemented in seven pipeline stages (D1 through D7). (See [TABLE 7-5](#) for details of these stages.)

TABLE 7-5 FPD Datapath Stages

Stage	Action
D1	Format input operand rs1
D2	Leading zero detect for rs1 Format input operand rs2
D3	Pre-normalize rs1 Leading zero detect for rs2
D4	Pre-normalize rs2
D5	Quotient loop (if normalized result, run 55 cycles DP, 26 cycles SP)
D6	Determine sticky bit from remainder
D7	Round

7.1.7 FPU Power Management

FPU power management is accomplished by way of block controllable clock gating. Clocks are dynamically disabled or enabled as needed, thus reducing clock power and signal activity when possible.

The FPU has independent clock control for each of the three execution pipelines (FPA, FPM, and FPD). Clocks are gated for a given pipeline when it is not in use, so a pipeline will have its clocks enabled only under one of the following conditions:

- The pipeline is executing a valid instruction
- A valid instruction is issuing to the pipeline
- The reset is active
- The test mode is active

The input FIFO queue and output arbitration blocks receive free running clocks. This eliminates potential timing issues, simplifies the design, and has only a small impact on the overall FPU power savings.

The FPU power management feature automatically powers up and powers down each of the three FPU execution pipelines, based on the contents of the instruction stream. Also, the pipelines are clocked only when required. For example, when no divide instructions are executing, the FPD execution pipeline automatically powers down. Power management is provided without affecting functionality or performance, and it is transparent to the software.

7.1.8 Floating-Point State Register Exceptions and Traps

The SPARC core FFU physically contains the architected floating-point state register (FSR). The characteristics of the FSR, as well as exceptions and traps, include:

- The FFU provides FSR.rd (IEEE rounding direction) to the FPU. IEEE non-standard mode (FSR.ns) is ignored by the FPU, and thus is not provided by the FFU.
- The FFU executes all floating-point move (FMOV) instructions. The FPU does not require any conditional move information. A 2-bit FSR condition code (FCC) field identifier (fcc0, fcc1, fcc2, fcc3) is provided to the FPU so that the floating-point compare (FCMP) target fcc field is known when the FPU result is returned to the FFU.
- The FPU provides IEEE exception status flags to the FFU for each instruction completed. The FFU determines if a software trap (fp_exception_ieee_754) is required based on the IEEE exception status flags supplied by the FPU and the IEEE trap enable bits located in the architected FSR.
- A denormalized operand or result will never generate an unfinished FPop trap to the software. The hardware provides full support for denormalized operands and results.
- Each of the five IEEE exception status flags and associated trap enables are supported – invalid operation, zero divide, overflow, underflow, and inexact.
- IEEE traps enabled mode – if an instruction generates an IEEE exception when the corresponding trap enable is set, then a fp_exception_ieee_754 trap is generated and results are inhibited by the FFU.
 - The destination register remains unchanged
 - FSR condition codes (fcc) remain unchanged
 - FSR.aexc field remains unchanged
 - FSR.cexc field has one bit set corresponding to the IEEE exception
- All four IEEE round modes are supported in hardware.
- The five IEEE exception status flags include:
 - Invalid (nv)
 - Overflow (of)
 - Underflow (uf)
 - Division-by-zero (dz)
 - Inexact (nx)

- The FSR contains a 5-bit field for current exceptions (FSR.cexc) and a 5-bit field for accrued exceptions (FSR.aexc). Each IEEE exception status flag has a corresponding trap enable mask (TEM) in the FSR:
 - Invalid mask – NVM
 - Overflow mask – OFM
 - Underflow mask – UFM
 - Division-by-zero mask – DZM
 - Inexact mask – NXM
- The FPU does not receive the FSR.TEM bits. The FSR.TEM bits are used within the FFU for the following cases:
 - `fp_exception_ieee_754` trap detection: If a FPop generates an IEEE exception (nv, of, uf, dz, nx) when the corresponding trap enable (TEM) bit is set, then a `fp_exception_ieee_754` trap is caused. The FSR.cexc field has one bit set corresponding to the IEEE exception, and the FSR.aexc field remains unchanged.
 - Clear the FSR.nxc flag if an overflow (underflow) exception does a trap because the FSR.OFM (FSR.UFM) mask is set, regardless of whether the FSR.NXM mask is set. Set FSR.ofc (FSR.ufc).
 - Clear the FSR.ofc (FSR.ufc) flag if overflow (underflow) exception traps when the FSR.OFM (FSR.UFM) mask is not set and the FSR.NXM mask is set. Set FSR.nxc.
 - Clear the FSR.ufc flag if the result is exact (and the FSR.nxc flag is not set) and the FSR.UFM mask is not set. This case represents an exact denormalized result.
- There are three types of FPU related traps tracked in the architected trap type (TT) register located in the SPARC core TLU:
 - `fp_disabled`
External to the FPU, the SPARC core IFU detects the `fp_disabled` trap type.
 - `fp_exception_ieee_754`
If an FPop generates an IEEE exception (nv, of, uf, dz, nx) when the corresponding trap enable (TEM) bit is set, then an `fp_exception_ieee_754` trap is caused. The FFU detects this trap type.
 - `fp_exception_other`
In the OpenSPARC T1 implementation, `fp_exception_other` trap results from an unimplemented FPop. The FFU detects unimplemented FPops.

7.1.8.1 Overflow and Underflow

An overflow occurs when the magnitude of what would have been the rounded result (had the exponent range been unbounded) is greater than the magnitude of the largest finite number of the specified precision. FPA, FPM, and FPD support all overflow conditions.

The underflow exception condition is defined separately for the trap-enabled and trap-disabled states.

- FSR.UFM = 1 – underflow occurs when the intermediate result is *tiny*
- FSR.UFM = 0 – underflow occurs when the intermediate result is *tiny* and there is a *loss of accuracy*

A *tiny* result is detected before rounding, when a non-zero result value is computed as though the exponent range were unbounded and would be less in magnitude than the smallest normalized number.

Loss of accuracy is detected when the delivered result value differs from what would have been computed had both the exponent range and the precision been unbounded (an inexact condition).

The FPA, FPM, and FPD will signal an underflow to the SPARC core FFU for all *tiny* results. The FFU must clear the FSR.ufc flag if the result is exact (the FSR.nxc is not set) and the FSR.UFM mask is not set. This case represents an exact denormalized result.

7.1.8.2 IEEE Exception List

TABLE 7-6 lists the IEEE exception cases and their OpenSPARC T1 generated results.

Note – The FPU does not receive the trap enable mask (FSR.TEM). The FSR.TEM bits are used within the FFU. If an instruction generates an IEEE exception when the corresponding trap enable is set, then an `fp_exception_ieee_754` trap is generated and the results are inhibited by the FFU.

TABLE 7-6 IEEE Exception Cases

Instruction	Invalid	Divide by zero	Overflow	Underflow or Denormalized	Inexact
FABS(s,d)	Executed in SPARC core FFU (cannot generate IEEE exceptions)				
FADD(s,d)	<ul style="list-style-type: none"> SNaN $\infty - \infty$ result=NaN ^{1,2} FSR.nvc=1		result= \pm max or $\pm\infty$ FSR.ofc=1 ⁴	result= ± 0 or \pm min or \pm denorm FSR.ufc=1 ^{5, 4}	result=IEEE ⁶ FSR.nxc=1 ⁷
FCMP(s,d)	<ul style="list-style-type: none"> SNaN result=fcc FSR.nvc=1				
FCMPE(s,d)	<ul style="list-style-type: none"> NaN result=fcc FSR.nvc=1				
FDIV(s,d)	<ul style="list-style-type: none"> SNaN $0 \div 0$ $\infty \div \infty$ result=NaN ^{1, 2} FSR.nvc=1	<ul style="list-style-type: none"> $x \div 0$, for $x \neq 0$ or ∞ or NaN result= $\pm\infty$ FSR.dzc=1	result= \pm max or $\pm\infty$ FSR.ofc=1 ⁴	result= ± 0 or \pm min or \pm denorm FSR.ufc=1 ^{5, 4}	result=IEEE ⁶ FSR.nxc=1 ⁷
FiTOs					result=IEEE ⁶ FSR.nxc=1
FiTOD	Cannot generate IEEE exceptions				
FMOV(s,d)	Executed in SPARC core FFU (cannot generate IEEE exceptions)				
FMOV(s,d)cc	Executed in SPARC core FFU (cannot generate IEEE exceptions)				
FMOV(s,d)r	Executed in SPARC core FFU (cannot generate IEEE exceptions)				
FMUL(s,d)	<ul style="list-style-type: none"> SNaN $\infty \times 0$ result=NaN ^{1, 2} FSR.nvc=1		result= \pm max or $\pm\infty$ FSR.ofc=1 ⁴	result= ± 0 or \pm min or \pm denorm FSR.ufc=1 ^{5, 4}	result=IEEE ⁶ FSR.nxc=1 ⁷
FNEG(s,d)	Executed in SPARC core FFU (cannot generate IEEE exceptions)				

TABLE 7-6 IEEE Exception Cases (*Continued*)

Instruction	Invalid	Divide by zero	Overflow	Underflow or Denormalized	Inexact
FsMULd	<ul style="list-style-type: none"> • SNaN • $\infty \times 0$ result=NaN ^{1, 2} FSR.nvc=1				
FSQRT(s,d)	Unimplemented				
F(s,d)TOi	<ul style="list-style-type: none"> • NaN • • • large result=max \pm integer ³ FSR.nvc=1				result=IEEE ⁶ FSR.nxc=1
FsTOd	<ul style="list-style-type: none"> • SNaN result=NaN ² FSR.nvc=1				
FdTOs	<ul style="list-style-type: none"> • SNaN result=NaN ² FSR.nvc=1		result= \pm max or $\pm\infty$ FSR.ofc=1 ⁴	result= ± 0 or \pm min or \pm denorm FSR.ufc=1 ^{5, 4}	result=IEEE ⁶ FSR.nxc=1 ⁷
F(s,d)TOx	<ul style="list-style-type: none"> • NaN • • • large result=max \pm integer ³ FSR.nvc=1				result=IEEE ⁶ FSR.nxc=1
FSUB(s,d)	<ul style="list-style-type: none"> • SNaN • $\infty - \infty$ result=NaN ^{1, 2} FSR.nvc=1		result= \pm max or $\pm\infty$ FSR.ofc=1 ⁴	result= ± 0 or \pm min or \pm denorm FSR.ufc=1 ^{5, 4}	result=IEEE ⁶ FSR.nxc=1 ⁷
FxTO(s,d)					result=IEEE ⁶ FSR.nxc=1

1 Default response QNaN = x'7ff...fff'

2 SNaN input propagated and transformed to QNaN result

3 Maximum signed integer (x'7ff...fff' or x'800...000')

4 FFU will clear FSR.ofc (FSR.ufc) if overflow (underflow) exception traps and FSR.OFM (FSR.UFM) is not set and FSR.NXM is set. FFU will set FSR.nxc.

5 FFU will clear FSR.ufc if the result is exact (FSR.nxc is not set) and FSR.UFM is not set. This case represents an exact denormalized result.

6 Rounded or overflow (underflow) result.

7 FFU will clear FSR.nxc if an overflow (underflow) exception does trap because FSR.OFM (FSR.UFM) is set, regardless of whether FSR.NXM is set. FFU will set FSR.ofc (FSR.ufc).

7.2 I/O Signal list

TABLE 7-7 describes the I/O Signals for the OpenSPARC T1 floating-point unit (FPU).

TABLE 7-7 FPU I/O Signal List

Signal Name	I/O	Source/Destination	Description
pcx_fpio_data_rdy_px2	In	CCX:PCX	FPU request ready from the PCX
pcx_fpio_data_px2[123:0]	In	CCX:PCX	FPU request packet from the PCX
arst_l	In	CTU	Chip asynchronous reset – asserted low
grst_l	In	CTU	Chip synchronous reset – asserted low
gclk	In	CTU	Chip clock
cluster_cken	In	CTU	Cluster clock enable
ctu_tst_pre_grst_l	In	CTU	
global_shift_enable	In	CTU	
ctu_tst_scan_disable	In	CTU	
ctu_tst_scanmode	In	CTU	
ctu_tst_macrottest	In	CTU	
ctu_tst_short_chain	In	CTU	
si	In	DFT	Scan in
fp_cpx_req_cq[7:0]	Out	CCX:CPX	FPU result request to the CPX
fp_cpx_data_ca[144:0]	Out	CCX:CPX	FPU result packet to the CPX
so	Out	DFT	Scan out

DRAM Controller

This chapter describes the following topics for the double data rate two (DDR-II) dynamic random access memory (DRAM) controller:

- [Section 8.1, “Functional Description” on page 8-1](#)
- [Section 8.2, “I/O Signal List” on page 8-9](#)

8.1 Functional Description

The OpenSPARC T1 DDR-II DRAM controller has the following characteristics:

- There are four independent DRAM controllers – each controller is connected to one L2-cache bank and one DDR-II memory channel
- Supports a maximum physical address space of 37 bits, for a maximum memory size of 128 Gbytes
- 64-byte cache lines are interleaved across four channels
- Operational range of 125 MHz to 200 MHz with a data rate of 250 to 400 MT/sec
- Peak bandwidth of 23 Gbyte/sec at 200 MHz.
- Error correction code (ECC) is based on single nibble correction and double nibble error detection (128 bit data + 16-bit ECC)
- Supports the chip kill feature
- The DRAM controller has three clock domains – CMP, DRAM, and J-Bus
- The DRAM controller operates in two modes – four channel mode or two channel mode (the mode is software programmable)
- The DRAM controller services L2-cache read requests from the DIMMs
 - Out-of-bound read addresses are returned with a multiple bit ECC (MECC) error
 - Reply zero data for L2-cache dummy read requests

8.1.1 Arbitration Priority

The read requests have higher priority over write requests, but there is a starvation counter which will enable writes to go through. Write requests that match the pending read requests are completed ahead for ordering. The DRAM controller should never see a read request followed by write request. The arbitration priority order is listed as follows, with the first list item having the highest priority:

1. Refresh request.
2. Pending column address strobe (CAS) requests (round-robin).
3. Scrub row address strobe (RAS) requests.
4. Write pending RAS requests, which have matching addresses, as read requests that are picked for RAS.
5. Read RAS requests from read queues, or write RAS requests from write queues when the write starvation counter reaches its limit (round-robin).
6. Write RAS requests from write queues, or read RAS requests from read queues if the write starvation counter reaches its limit.
7. Incoming read RAS requests.

8.1.2 DRAM Controller State Diagrams

FIGURE 8-2 presents a top-level state diagram of the DRAM controller. Software must initialize the DRAM controller at power-on in order for it to achieve an initialized state.

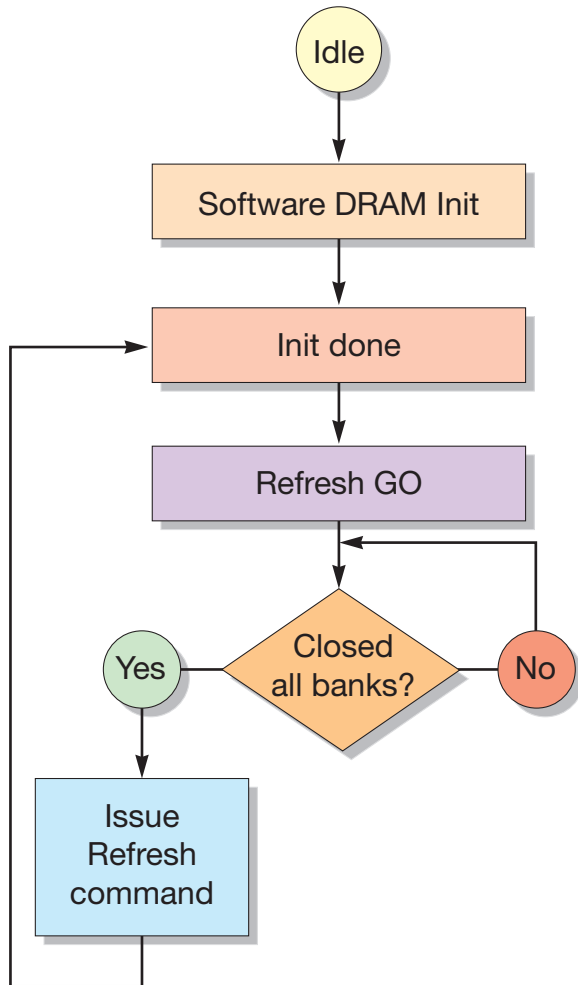

FIGURE 8-2 DDR-II DRAM Controller Top-Level State Diagram

FIGURE 8-3 displays the DIMM scheduler state diagram. The DIMM scheduler has three main states – wait, CAS pick, and RAS pick. Whenever a CAS or a RAS request exists and timing is met, the scheduler goes into a CAS pick or a RAS pick state.

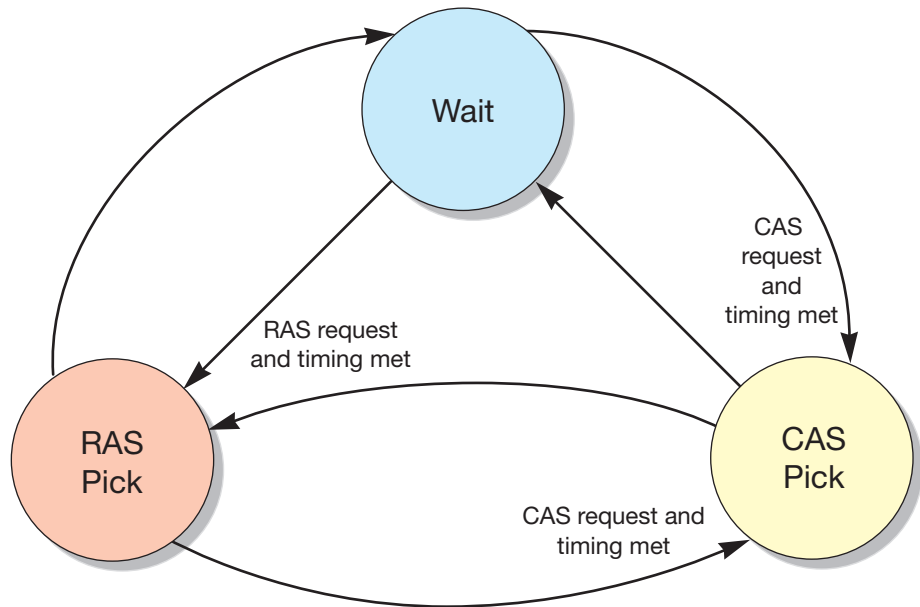

FIGURE 8-3 DIMM Scheduler State Diagram

8.1.3 Programmable Features

The DRAM chips on the DIMMs contain a number of timing parameters that need to be controlled. These chips are controlled by programming the CSRs in the DRAM controller. For complete list of registers and bit definitions, refer to the *UltraSPARC T1 Supplement to UltraSPARC 2005 Architecture Specification* document. Here is the list of some of the programmable parameters:

- RAS address width
- CAS address width
- CAS latency (CL)
- Refresh frequency
- Scrub frequency
- RAS-to-RAS delay to different bank (Trrd)
- RAS-to-RAS delay to same bank (Trc)
- RAS-to-CAS delay (Trcd)

- Write-to-read delay
- Read-to-write delay
- Programmable data expect cycles

8.1.4 Errors

The DRAM controller error mechanism has the following characteristics:

- Error injection can be done through software programming
- Error registers are accessible by way of the IOB interface
- Error counter registers can send an interrupt when reaching a programmed count
- All correctable and uncorrectable errors are logged and sent to the L2-cache along with the data
- DRAM scrub errors are also forwarded to L2-cache independently
- Error location register logs the error nibble position on correctable errors
- The scrub error address is also logged in the error address register

8.1.5 Repeatability and Visibility

- For repeatability:
 - The arbiter states for the RAS and the CAS picker are reset
 - The scrub address is reset
 - The refresh counter is software programmable (it does not reset)
- Visibility is plenty for address/data
 - The address can be reconstructed from the RAS and CAS address, chip select, and bank bits by knowing the configuration registers
 - External visible check bits have to be XORed with the address parity in order to get the true ECC

8.1.6 DDR-II Addressing

The characteristics of DDR-II addressing include:

- Burst lengths of 4 and 8 are supported
- Various DRAM chips are supported and their addressing is shown in [TABLE 8-1](#)
- The address bit A10 is used as auto-precharge bit

TABLE 8-1 DDR-II Addressing

Base Device	Part	Number of Banks	Bank Address	Row Address	Column Address
256 Mbyte	x4	4	BA[1:0]	A[12:0]	A[11],A[9:0]
512 Mbyte	x4	4	BA[1:0]	A[13:0]	A[11],A[9:0]
1 Gbyte	x4	8	BA[2:0]	A[13:0]	A[11],A[9:0]
2 Gbyte	x4	8	BA[2:0]	A[14:0]	A[11],A[9:0]
4 Gbyte	x4	8	BA[2:0]	A[15:0]	A[11],A[9:0]

- The DRAM bank bits are hashed as follows:

`new_dimm_bank[2:0] = dimm_bank[2:0] ^ addr[20:18] ^ addr[30:28]`

- [TABLE 8-2](#) shows the physical address (PA) decoding to the DIMM address (bank address, row address, and column address).

TABLE 8-2 Physical Address to DIMM Address Decoding

Total Memory Per Channel	DIMM Density / Type	DRAM Component Used	RANK	Stacked DIMM	DIMM Bank Address (BA)	Row Address	Column Address
1 Gbytes	512 Mbyte unstacked	256 Mbit			PA[9:8]	PA[31:19]	{PA[18:10],PA[5:4]}
2 Gbytes with Rank	512 Mbyte unstacked	256 Mbit	PA[32]		PA[9:8]	PA[31:19]	{PA[18:10],PA[5:4]}
2 Gbytes	1 Gbyte stacked	256 Mbit		PA[32]	PA[9:8]	PA[31:19]	{PA[18:10],PA[5:4]}
4 Gbytes with Rank	1 Gbyte stacked	256 Mbit	PA[33]	PA[32]	PA[9:8]	PA[31:19]	{PA[18:10],PA[5:4]}
4 Gbytes	2 Gbytes unstacked	1 Gbit			PA[10:8]	PA[33:20]	{PA[19:11],PA[5:4]}

8.1.7 DDR-II Supported Features

The DRAM controller supports the following DDR-II features:

- DIMMs with component sizes 256 Mbit to 2 Gbit are supported
- Only x4 SDRAM parts are supported
- DIMMs on one channel should have same timing parameters
- Banks are always closed after a read or a write
- Supports a burst length of 4
- There is one fixed dead cycle for switching commands from one rank to another rank
- A single-ended DQS is used
- An off-chip driver (OCD) is *not* supported
- SDRAM on-die termination (ODT) is *not* supported
- The additive latency (AL) is always zero

TABLE 8-3 lists the subset of DDR-II SDRAM commands used by the OpenSPARC T1 processor.

TABLE 8-3 DDR-II Commands Used by OpenSPARC T1 Processor

Function	CKE Previous Cycle	CKE Current Cycle	CS_L	RAS_L	CAS_L	WE_L	Bank	Address
Mode/extended mode register set	H	H	L	L	L	L	BA	Op-code
Auto refresh	H	H	L	L	L	H	X	X
Self refresh entry	H	L	L	L	L	H	X	X
Self refresh exit	L	H	H	X	X	X	X	X
			L	H	H	H		
Precharge all banks	H	H	L	L	H	L	X	A10=H
Bank activate	H	H	L	L	H	H	BA	Row Address
Write with auto precharge	H	H	L	H	L	L	BA	Column address, A10=H
Read with auto precharge	H	H	L	H	L	H	BA	Column address, A10=H
No operation	H	X	L	H	H	H	X	X
Device deselect	H	X	H	X	X	X	X	X

8.2 I/O Signal List

TABLE 8-4 lists the I/O signals for OpenSPARC T1 DDR-II DRAM controller.

TABLE 8-4 DRAM Controller I/O Signal List

Signal Name	I/O	Source/ Destination	Description
dram_other_pt_max_banks_open_valid	In		
dram_other_pt_max_time_valid	In		
dram_other_pt_ucb_data[16:0]	In		
dram_other_pt0_opened_bank	In		
dram_other_pt1_opened_bank	In		
io_dram0_data_in[255:0]	In	PADS	I/O data in
io_dram0_data_valid	In	PADS	I/O data valid
io_dram0_ecc_in[31:0]	In	PADS	I/O ECC in
io_dram1_data_in[255:0]	In	PADS	I/O data in
io_dram1_data_valid	In	PADS	I/O data valid
io_dram1_ecc_in[31:0]	In	PADS	I/O ECC in
iob_ucb_data[3:0]	In	IOB	UCB data
iob_ucb_stall	In	IOB	UCB stall
iob_ucb_vld	In	IOB	UCB valid
scbuf0_dram_data_mecc_r5	In	SCBUF0	
scbuf0_dram_data_vld_r5	In	SCBUF0	
scbuf0_dram_wr_data_r5[63:0]	In	SCBUF0	To dramctl0 of dramctl.v
scbuf1_dram_data_mecc_r5	In	SCBUF1	
scbuf1_dram_data_vld_r5	In	SCBUF1	
scbuf1_dram_wr_data_r5[63:0]	In	SCBUF1	To dramctl1 of dramctl.v
sctag0_dram_addr[39:5]	In	SCTAG0	To dramctl0 of dramctl.v
sctag0_dram_rd_dummy_req	In	SCTAG0	
sctag0_dram_rd_req	In	SCTAG0	To dramctl0 of dramctl.v
sctag0_dram_rd_req_id[2:0]	In	SCTAG0	To dramctl0 of dramctl.v

TABLE 8-4 DRAM Controller I/O Signal List (*Continued*)

Signal Name	I/O	Source/ Destination	Description
sctag0_dram_wr_req	In	SCTAG0	To dramctl0 of dramctl.v
sctag1_dram_addr[39:5]	In	SCTAG1	To dramctl1 of dramctl.v
sctag1_dram_rd_dummy_req	In	SCTAG1	
sctag1_dram_rd_req	In	SCTAG1	To dramctl1 of dramctl.v
sctag1_dram_rd_req_id[2:0]	In	SCTAG1	To dramctl1 of dramctl.v
sctag1_dram_wr_req	In	SCTAG1	To dramctl1 of dramctl.v
clspine_dram_rx_sync	In	CTU	RX synchronous
clspine_dram_tx_sync	In	CTU	TX synchronous
clspine_jbus_rx_sync	In	CTU	RX synchronous
clspine_jbus_tx_sync	In	CTU	TX sync
dram_gdbginit_l	In	CTU	Debug init for repeatability @ J-Bus freq
clk_dram_jbus_cken	In	CTU	J-Bus clock enable
clk_dram_dram_cken	In	CTU	DDR clock enable
clk_dram_cmp_cken	In	CTU	CMP clock enable
clspine_dram_selfrsh	In	CTU	Signal from clock to put in self refresh @J-Bus freq
global_shift_enable	In	CTU	Scan shift enable signal
dram_si	In	DFT	Scan in
jbus_gclk	In	CTU	J-Bus clock
dram_gclk	In	CTU	DDR clock
cmp_gclk	In	CTU	CMP clock
dram_adbginit_l	In	CTU	Active low async reset of dbginit_l
dram_arst_l	In	CTU	Active low async reset of rst_l
jbus_grst_l	In	CTU	Active low reset signal
dram_grst_l	In	CTU	Active low reset signal
cmp_grst_l	In	CTU	Active low reset signal
ctu_tst_scanmode	In	CTU	
ctu_tst_pre_grst_l	In	CTU	
ctu_tst_scan_disable	In	CTU	
ctu_tst_macrotest	In	CTU	

TABLE 8-4 DRAM Controller I/O Signal List (*Continued*)

Signal Name	I/O	Source/ Destination	Description
ctu_tst_short_chain	In	CTU	
dram_io_addr0[14:0]	Out	PADS	DRAM address 0
dram_io_addr1[14:0]	Out	PADS	DRAM address 1
dram_io_bank0[2:0]	Out	PADS	DRAM bank 0
dram_io_bank1[2:0]	Out	PADS	DRAM bank 1
dram_io_cas0_l	Out	PADS	DRAM CAS 0
dram_io_cas1_l	Out	PADS	DRAM CAS 1
dram_io_channel_disabled0	Out	PADS	DRAM channel disable 0
dram_io_channel_disabled1	Out	PADS	DRAM channel disable 1
dram_io_cke0	Out	PADS	DRAM CKE 0
dram_io_cke1	Out	PADS	DRAM CKE 1
dram_io_clk_enable0	Out	PADS	DRAM clock enable 0
dram_io_clk_enable1	Out	PADS	DRAM clock enable 1
dram_io_cs0_l[3:0]	Out	PADS	DRAM CS 0
dram_io_cs1_l[3:0]	Out	PADS	DRAM CS 1
dram_io_data0_out[287:0]	Out	PADS	DRAM data 0
dram_io_data1_out[287:0]	Out	PADS	DRAM data 1
dram_io_drive_data0	Out	PADS	From dramctl0 of dramctl.v
dram_io_drive_data1	Out	PADS	From dramctl1 of dramctl.v
dram_io_drive_enable0	Out	PADS	From dramctl0 of dramctl.v
dram_io_drive_enable1	Out	PADS	From dramctl1 of dramctl.v
dram_io_pad_clk_inv0	Out	PADS	
dram_io_pad_clk_inv1	Out	PADS	
dram_io_pad_enable0	Out	PADS	
dram_io_pad_enable1	Out	PADS	
dram_io_ptr_clk_inv0[4:0]	Out	PADS	
dram_io_ptr_clk_inv1[4:0]	Out	PADS	
dram_io_ras0_l	Out	PADS	DRAM RAS 0
dram_io_ras1_l	Out	PADS	DRAM RAS 1
dram_io_write_en0_l	Out	PADS	DRAM write enable 0

TABLE 8-4 DRAM Controller I/O Signal List (*Continued*)

Signal Name	I/O	Source/ Destination	Description
dram_io_write_en1_l	Out	PADS	DRAM write enable 1
dram_sctag0_data_vld_r0	Out	SCTAG0	
dram_sctag0_rd_ack	Out	SCTAG0	
dram_sctag0_scb_mecc_err	Out	SCTAG0	
dram_sctag0_scb_secc_err	Out	SCTAG0	
dram_sctag0_wr_ack	Out	SCTAG0	
dram_sctag1_data_vld_r0	Out	SCTAG1	
dram_sctag1_rd_ack	Out	SCTAG1	
dram_sctag1_scb_mecc_err	Out	SCTAG1	
dram_sctag1_scb_secc_err	Out	SCTAG1	
dram_sctag1_wr_ack	Out	SCTAG1	
ucb_iob_data[3:0]	Out	IOB	UCB data
ucb_iob_stall	Out	IOB	UCB stall
ucb_iob_vld	Out	IOB	UCB valid
dram_sctag0_chunk_id_r0[1:0]	Out	SCTAG0	
dram_sctag0_mecc_err_r2	Out	SCTAG0	
dram_sctag0_rd_req_id_r0[2:0]	Out	SCTAG0	
dram_sctag0_secc_err_r2	Out	SCTAG0	
dram_sctag1_chunk_id_r0[1:0]	Out	SCTAG1	
dram_sctag1_mecc_err_r2	Out	SCTAG1	
dram_sctag1_rd_req_id_r0[2:0]	Out	SCTAG1	
dram_sctag1_secc_err_r2	Out	SCTAG1	
dram_scbuf0_data_r2[127:0]	Out	SCBUF0	
dram_scbuf0_ecc_r2[27:0]	Out	SCBUF0	
dram_scbuf1_data_r2[127:0]	Out	SCBUF1	
dram_scbuf1_ecc_r2[27:0]	Out	SCBUF1	
dram_local_pt0_opened_bank	Out		
dram_local_pt1_opened_bank	Out		
dram_pt_max_banks_open_valid	Out		
dram_pt_max_time_valid	Out		

TABLE 8-4 DRAM Controller I/O Signal List (*Continued*)

Signal Name	I/O	Source/ Destination	Description
dram_pt_ucb_data[16:0]	Out		
dram_clk_tr	Out	CTU	Debug trigger @ J-Bus freq
dram_so	Out	DFT	Scan out

Error Handling

This chapter describes the following topics:

- [Section 9.1, “Error Handling Overview” on page 9-1](#)
- [Section 9.2, “SPARC Core Errors” on page 9-3](#)
- [Section 9.3, “L2-Cache Errors” on page 9-5](#)
- [Section 9.4, “DRAM Errors” on page 9-8](#)

9.1 Error Handling Overview

The OpenSPARC T1 processor detects, logs, and reports a number of errors to the software. This chapter describes the error types, and how various blocks detect, log and report these errors.

There are three types of errors in the OpenSPARC T1 processor:

1. Correctable errors (CE)

The correctable errors are fixed by the hardware, and the hardware can generate the disrupting traps so that the software can keep track of the error frequency or the failed/failing parts.

2. Uncorrectable errors (UE)

These types of errors are cannot be corrected by hardware, and hardware will generate precise, disrupting, or deferred traps. These errors can be corrected by software.

3. Fatal errors (FE)

These types of errors can create potentially unbounded damage and these types of errors will cause a warm reset.

9.1.1 Error Reporting and Logging

- The SPARC core errors are logged in program order and they are logged only after the instruction has *exited* the pipe (W-stage). The rolled back and flushed instructions do not log errors immediately. Errors are logged in the L2-cache and DRAM error registers in the order the errors occur.
- Errors are reported hierarchically in the following order – DRAM, L2-cache, and SPARC core. For diagnostic reasons, the L2-cache can be configured to not report errors to the SPARC core.
- SPARC, L2-cache, and DRAM error registers log error details for a single error only.
- Fatal and uncorrectable errors will overwrite earlier correctable error information.
- The error registers have bits to indicate if multiple errors occurred.
- Refer to the *UltraSPARC T1 Supplement to UltraSPARC Architecture 2005* for detailed information about error control and status register (CSR) definitions, including addresses, bit fields, and so on.

9.1.2 Error Traps

- Error trap logic is located in the SPARC core (IFU). Errors anywhere on the chip have to be reported here.
- Error traps can be disabled (typically for diagnostic reasons).
- Correctable errors cause a disrupting corrected ECC error trap.
- Uncorrectable errors can cause precise, disrupting, or deferred traps.
- L2-cache and DRAM errors are reported through CPX packets.
- There is a special CPX packet type that reports errors that cannot be attributed to a specific transaction (for example, an L2 evicted line with an UE).
- When IFU receives this packet, a `data_error` trap is taken.

The following sub-sections describe the errors in SPARC core, L2-cache, and DRAM. Errors in other blocks like IOB and JBI are described in their chapters.

9.2 SPARC Core Errors

This section describes the error registers, error protection, and error correction of the SPARC core.

9.2.1 SPARC Core Error Registers

Every thread in the SPARC core has its own set of hyper-privileged error registers. The error registers are described as:

- `ASI_SPARC_ERROR_EN_REG`:
 - `NCEEN`: If set, it will enable uncorrectable error traps.
 - `CEEN`: If set, it will enable correctable error traps.
 - POR value is 0.
 - Logging will occur even if error traps are disabled.
- `ASI_SPARC_ERROR_STATUS_REG`:
 - Logs the errors that occur.
 - Indicates if multiple errors occurred.
 - Indicates if the error occurred at a privileged level.
 - Not cleared on a hardware reset, so the software will need to do so.
 - Never cleared by the hardware.
- `ASI_SPARC_ERROR_ADDRESS_REG`:
 - Captures the address, syndrome, and so on as applicable.
- `ASI_ERROR_INJECT_REG`:
 - Used for error injection.
 - One per core, and shared by all threads.
 - Can specify one error source (from among the TLBs and the register file).
 - Error injection can be a single shot or multiple shots.
 - Diagnostic writes can be used to inject errors into the L1-caches.

9.2.2 SPARC Core Error Protection

All SRAMs, caches, TLBs, and so on in the SPARC core have error protection using either parity or ECC. TABLE 9-1 shows the SPARC core memories and their error protection types.

TABLE 9-1 Error Protection for SPARC Memories

Memory	Error Protection Type
ITLB data	Parity
ITLB tag	Parity
DTLB data	Parity
DTLB tag	Parity
Instruction cache data	Parity
Instruction cache tag	Parity
Data cache data	Parity
Data cache tag	Parity
Integer register file (IRF)	ECC
Floating-point register file (FRF)	ECC
Modular arithmetic (MA) memory	Parity

9.2.3 SPARC Core Error Correction

The SPARC core provides error correction for various errors as follows:

- Instruction/Data TLB Data Parity Error
 - Precise trap during translation.
 - Precise trap for ASI accesses.
- Instruction/Data TLB Tag Parity Error
 - Not checked during translation.
 - Precise trap for ASI accesses with periodic software scrubbing.
 - DTLB parity error on a store causes a *deferred* trap.
- Instruction/Data Cache Data/Tag Parity Error
 - Two requests to the L2-cache – the first invalidates the entire set and the second does a refill.
 - Data cache is not accessed for stores or atomics.

- Data cache errors on loads cause a rollback of the instruction following the load (from D or W stages).
- An instruction cache parity error on an instruction causes a rollback from the D-stage.
- IRF/FRF Correctable Error
 - The instruction is rolled back from W-stage and the error is corrected. The instruction is then replayed.
- IRF/FRF Uncorrectable Error
 - Causes a precise trap.
- I/O Load/Instruction Fetch Uncorrectable Error
 - Causes a precise trap.
- Modular Arithmetic Memory Error
 - SPU aborts the operation and logs the error.
 - Different synchronization modes result in different traps.
 - No address applies to this case.

9.3 L2-Cache Errors

This section lists the error registers and error protection types of the L2-cache. This section also describes the L2-cache correctable and uncorrectable errors.

9.3.1 L2-Cache Error Registers

Each L2-cache bank contains the following error registers:

- L2 Control Register, whose bits in this register are:
 - ERRORSTEER – specifies which of the 32 threads receives all the L2 errors whose cause cannot be linked to a specific thread.
 - SCRUBINTERVAL – the interval between scrubbing of adjacent sets in the L2-cache.
 - SCRUBENABLE – enable a hardware scrub.
- L2 Error Enable Register
 - NCEEN – if set, uncorrectable errors are reported to the SPARC core.
 - CEEN – if set, correctable errors are reported to the SPARC core.
 - Logging occurs even if reporting to the cores is disabled.

- L2 Error Status Register
 - Contains the error status for that bank.
 - Not cleared after a reset.
 - Indicates multiple errors if they have occurred.
- L2 Error Address Register
 - Logs the error address per cache bank.
 - PA for loads and stores, and other indices for scrub and directory errors.
- L2 Error Injection Register
 - Injects errors into the directory only.
 - L2 tags, valid used allocated and dirty (VUAD) array, and data array errors can be injected through diagnostic accesses.

9.3.2 L2-Cache Error Protection

All SRAMs, caches, and so on in the L2-cache have error protection using either parity or ECC. [TABLE 9-2](#) shows the L2-cache memories and their error protection types.

TABLE 9-2 Error Protection for L2-Cache Memories

Memory	Error Protection Type
L2-cache data	ECC
L2-cache tag	ECC
Directory	Parity
VAD bits	Parity
Writeback buffer	ECC

9.3.3 L2-Cache Correctable Errors

- Error information is captured in the L2-cache Error Status and L2-cache Error Address registers.
- If the L2-cache correctable error enable (CEEN) bit is set and the error is on the requested data, the error is also logged in the SPARC error status and error address registers.

- Loads, ifetch and prefetch – if the SPARC CEEN bit is set, a disrupting ECC_error trap is taken on the requesting thread.
 - Hardware corrects the error on the data being returned from the L2-cache, but it does not correct the L2-cache data itself.
 - Partial stores (less than 4 bytes), Atomics – error is corrected and written to the L2-cache.
- MA loads:
 - If the CEEN bit is set, the L2-cache notifies the SPU of the error.
 - If the INT bit is set in the SPU, there is an ECC_error trap on the thread specified in SPU control register (in addition to the completion interrupt). Or the error trap is signalled to IFU when the sync load occurs.
- Correctable errors detected on the writeback data, DMA read, or DMA partial writes (<4B) result in a ECC_error trap on the steering thread.
 - Errors on writeback data is fixed before writing to memory.
 - DMA partial stores correct the L2-cache data.
- Correctable errors detected during a scrub are logged in the L2-cache registers:
 - Corrected data is written to the L2-cache.
 - ECC_error trap is taken on the steering thread.
- Correctable errors detected on any of the 12 tags in a set during an access causes:
 - The hardware to correct all tags in the set.
 - An ECC_error trap on steering thread.

9.3.4 L2-Cache Uncorrectable Errors

- Error information is captured in the L2-cache error status and the L2-cache error address registers.
- If the L2 error enable non-correctable error enable (NCEEN) bit is set:
 - Error is also logged in the SPARC error status and the SPARC error address registers.
 - Erroneous data is loaded in the L1-cache with bad parity.
- If the SPARC error enable NCEEN bit is set, a precise trap is generated on the requesting thread.
- Partial Stores (less than 4 bytes):
 - Do not update the cache.
 - Generate a disrupting data_error trap on the requesting thread.
 - Mark the line dirty, and the memory keeps the bad ECC on writeback.

- Uncorrectable errors on writeback data, DMA reads, and scrub all cause a disrupting `data_error` trap on the steering thread.
- MA loads with uncorrectable errors, and aborts the operation in SPU.
- A fatal error indication is issued across the J-Bus in order to request a `warm_reset` of the entire chip when there is a:
 - Parity error on any of the 12 VAD bits in the set during any access.
 - Parity error during a directory scrub.

9.4 DRAM Errors

This section lists the error registers and the error protection of the DRAM. This section also describes the DRAM correctable and uncorrectable and addressing errors.

9.4.1 DRAM Error Registers

Each DRAM channel has its own set of error registers:

1. DRAM Error Status Register
 - Contains the status of the DRAM errors.
 - Not cleared on a reset.
2. DRAM Error Address Register
 - Contains the physical address of the DRAM scrub error.
 - DRAM access error addresses are logged by the L2-cache.
3. DRAM Error Location Register
 - Contains the location of the bad nibble.
4. DRAM Error Counter Register
 - 16-bit counter, decrements on every 16-byte correctable error.
 - An interrupt is sent to the IOB when the count hits 0.
5. DRAM Error Injection Register
 - An injection of a bad ECC on the data written to memory.
 - When `ENB=1` is set, the DRAM writes will be XOR'd with the normally generated ECC.

- Errors can be injected as either single-shot or continuously.
- In single-shot mode, after the first injected error is generated, the SSHOT and ENB are automatically reset by the hardware to 0.

9.4.2 DRAM Error Protection

Each DRAM bank has 16 bits of ECC for 128-bits of data.

9.4.3 DRAM Correctable Errors

- Corrected data written to the L1- or L2-caches.
- Error information is captured in the DRAM error status, L2-cache error status, and the L2-cache error address registers.
- If the L2-cache error enable CEEN and SPARC error enable CEEN bits are set, a disrupting ECC_error trap is generated.
- Load, ifetch, atomic, prefetch – an error on the critical chunk will be reported to the thread that requested the data, otherwise it will be reported to the steering thread.
- Stores, streaming stores, DMA reads, DMA writes – errors reported to the steering thread.
- Streaming loads – errors are reported to the streaming unit, which reports it to the thread programmed in the MA control register to receive the completion interrupt.
- A correctable error during a scrub is captured in the DRAM error status and DRAM error address registers, and the DSC bit is set in the L2-cache error status register.

9.4.4 DRAM Uncorrectable and Addressing Errors

- Error information is captured in the DRAM error status, L2-cache error status, and the L2-cache error address registers.
- If the L2-cache NCEEN bit is set, the error information is also captured in the SPARC error status and SPARC error address registers (as an L2-cache error).
- An out-of-bounds error is signalled as a cache line and marked with an uncorrectable error.
- For each 32-bit chunk with an error, the data is loaded into the L2-cache with poisoned ECC.
- An error on the critical chunk results in a precise trap on the requesting thread.

- An error on non-critical chunks results in a disrupting data_error trap to the steering thread.
- If an error is on the 16-byte chunk to be written, the stores will not update the L2-cache. The line is marked as dirty, so on eviction the line is written to the memory with a bad ECC.
- An uncorrectable error during a scrub is captured in the DRAM error status and DRAM error address registers, and if the DSU bit is set in the L2-cache error status register, a disrupting data_error trap is generated on the steering thread.

Clocks and Resets

This chapter describes the following topics:

- [Section 10.1, “Functional Description” on page 10-1](#)
- [Section 10.2, “I/O Signal list” on page 10-15](#)

10.1 Functional Description

The OpenSPARC T1 processor clock and test unit (CTU) contains three main components – clock generation and control, reset generation, and test. Because the test functions are physical design dependent, they are not described in this document. This chapter describes the OpenSPARC T1 processor’s clocks and resets.

10.1.1 OpenSPARC T1 Processor Clocks

There are three clock domains in the OpenSPARC T1 processor – chip-level multiprocessor (CMP) in the CPU clusters, J-Bus, and DRAM. Throughout this chapter, these three clock domains are referred in this document as *C* for CMP, *J* for J-Bus, and *D* for DRAM.

- Only one phased-locked loop (PLL) in the chip, which has a differential J_CLK[1:0], is used as a reference clock for the PLL. This clock runs at 150 MHz at power-up, and then it is increased to 200 MHz (or any other target frequency between 150 MHz to 200 MHz).
- Each domain (C, D, and J) has its own balanced clock distribution tree.
- Signals from the CTU are delivered to the cluster’s clock headers. The C clock domain uses flop repeaters for clock distribution.

- The CTU has the following sub-blocks – PLL (clock PLL), random number generator (RNG), design For testability (DFT), clock spine (CLSP), the temperature sensor (TSR).
- The CTU generates the following signals for each cluster – clock, clock enable, reset (synchronous and asynchronous), init (debug init), sync pulses for clock domain crossing, and built-in self test (BIST) signals for blocks with memory BIST.
- For debugging purposes, the CTU receives a trigger signal from the cluster.
- The CTU and PADS themselves are clock and reset recipients.

FIGURE 10-1 displays a high-level block diagram of the CTU clock and reset signals and CTU sub-blocks.

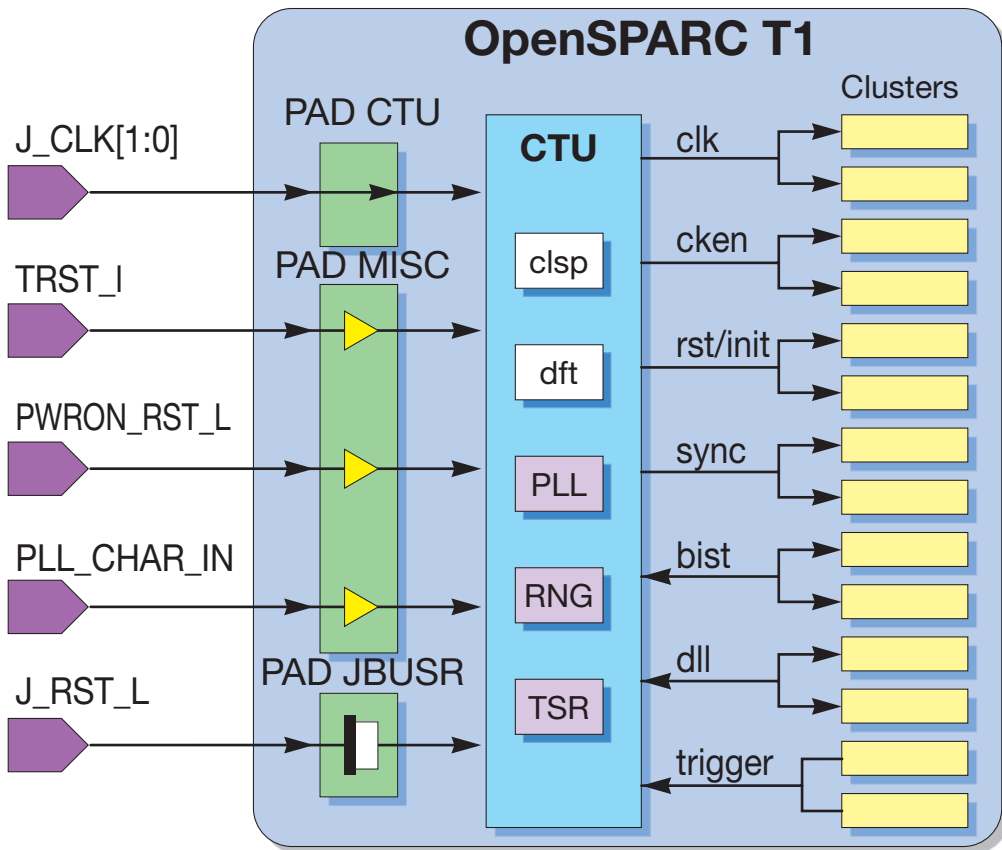

FIGURE 10-1 Clock and Reset Functional Block Diagram

10.1.1.1 Phase-Locked Loop

The phase-locked loop (PLL) has two modes of operation – PLL bypass and PLL locked mode.

- Bypass mode – in this mode, the `clk_out` (clock output) follows `J_CLK`, VCO and divider are set to *don't care*.
- PLL locked mode – `clk_out` is OFF when `ARST_L` is asserted, the voltage control oscillator (VCO) ramps up at an `ARST_L` deassertion, the divider is free running, and the feedback is matched to the clock tree output.

FIGURE 10-2 shows the PLL block diagram including the VCO and the feedback path.

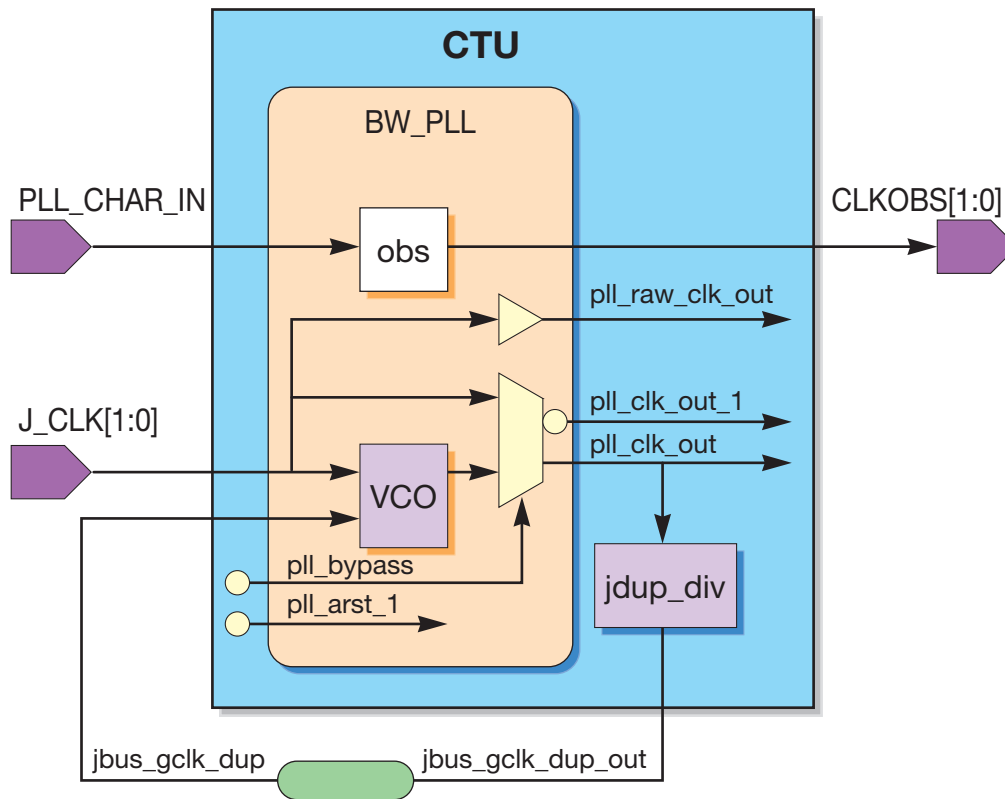

FIGURE 10-2 PLL Functional Block Diagram

10.1.1.2 Clock Dividers

A clock divider divides the output of the PLL, and supports a divide range of 2 to 24. The clock dividers are Johnson counter variants and have deterministic starts for repeatability.

Each clock domain (C, D, and J) are generated by the dividing PLL clock, and each domain uses its own divide ratio and positive/negative pairs. For the PLL bypass mode, the divide ratios are fixed – the C clock is divided by 1, and D and J clocks are divided by 4. Refer to the *UltraSPARC T1 Supplement to the UltraSPARC 2005 Architecture Specification* for the complete definitions of these clock divider ratios.

Clock divider block diagram and waveforms are shown in [FIGURE 10-3](#).

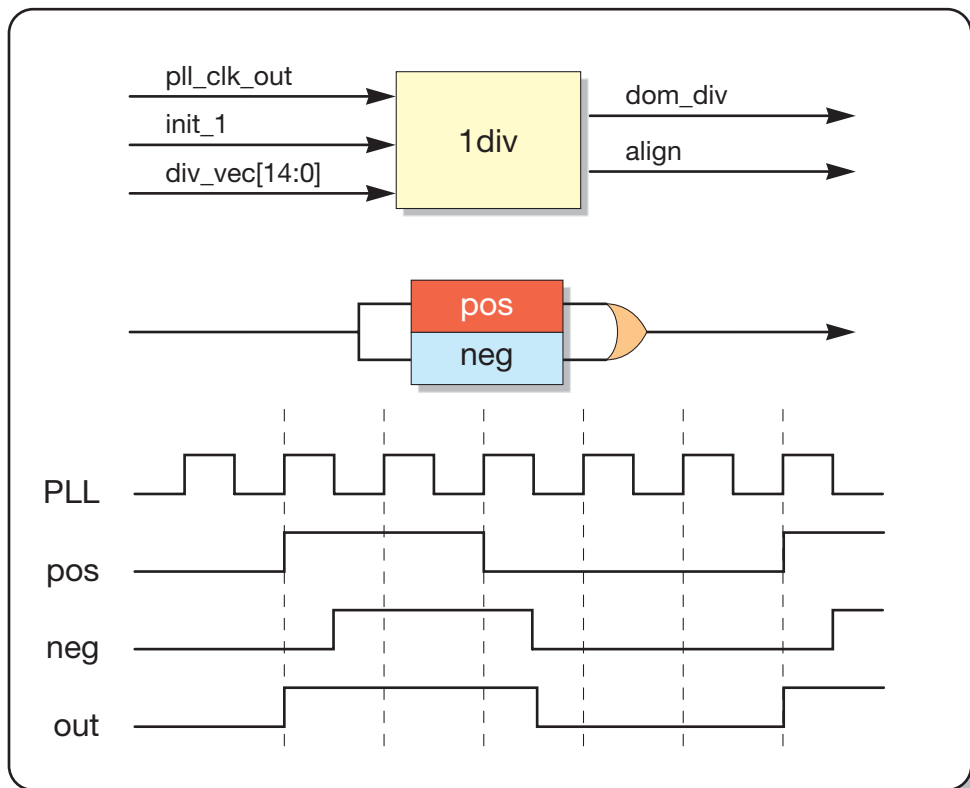

FIGURE 10-3 Clock Divider Block Diagram

The clock divider and other parameters are stored in shadowed control registers (CREGs). A cold reset (or a power-on reset) sets the default values in each CREG and its shadow. Warm resets with frequency changes copies the CREG to its shadow.

TABLE 10-1 defines the various dividers for the clock domains.

TABLE 10-1 Clock Domain Dividers

C-Divider	D-Divider	J-Divider	Description
1	4	4	Power On default - PLL Bypass mode
4	16	16	Power On default - PLL Locked mode
2	14	12	Expected nominal ratios

10.1.1.3 Clock Domain Crossings

Clock domain crossing has the following characteristics:

- Clock domains are ratioed synchronous, which means that after every few clock cycles (depending on the ratio), the clock edge will align.
- Only C<>D and C<>J clock domain crossings are supported.
- Domain crossing is governed by the Rx/Tx *sync* pulses, which are named with respect to the domain (for example, dram_rx_sync means the C domain is receiving from the D domain).
- Sync pulses are generated in the C domain, and are used as clock enables for the C domain flops.
- Domain crossing paths are time delayed as a single cycle path in C domain.
- The prescribed usage allows electrical correctness, and the logical correctness is still up to surrounding logic.

FIGURE 10-4 shows a waveform for cross domain crossing Rx and Tx pulses.

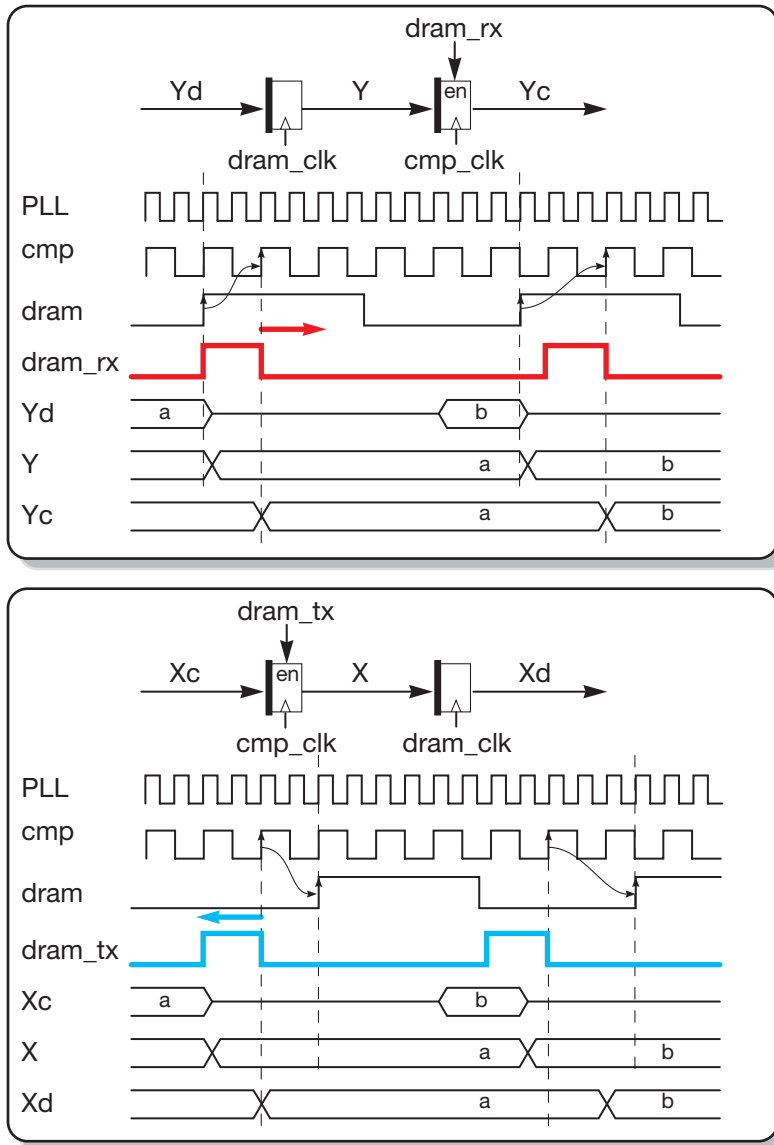

FIGURE 10-4 Sync Pulses Waveforms

10.1.1.4 Clock Gating

Clock gating has the following characteristics:

- The CTU will occasionally gate an entire domain off/on.
- Each cluster can be gated off/on separately.
- Reset sequences do a sequenced turn-off/on.
- After a reset, the software can turn each cluster off.
- CREG_CKEN has one bit per cluster (except CTU), and bits are reset to all ones by a reset sequence.
- CREG_CKEN is *NOT* shadowed, and the effect is *immediate*.
- Turning off some clusters could be fatal, but it can be recovered with a test access port (TAP) reset.
- Turning off the IOB is catastrophic, and will require a reset sequence to recover.

10.1.1.5 Clock Stop

Clock stop event have the following characteristics:

- Clock stop events can be chosen from a wide palette.
- When a clock stop event occurs, a *trigger* is sent to the CTU.
- The CTU does a sequenced clock enable (CKEN) turn-off:
 - Can be staggered or instant, which is controlled by the CREG_CLK_CTL.OSSDIS.
 - The first cluster to turn off is defined by the TAP, and the progression is in the CREG_CLK_CTL bit order with wraparound.
 - The time the first cluster is turned off is controlled by CREG_CLK_DLL.DBG_DLY.
 - The gap between clusters is controlled by CREG_CLK_CTL.STP_DLY.
- After a clock stop, you can use JTAG to do a scan dump and a macro dump.
- After a clock stop and JTAG dump, you need to perform a cold reset to continue.

10.1.1.6 Clock Stretch

Clocks can be *stretched* by making dividers skip one PLL beat. The C, D, and J clock domains are stretched simultaneously (however, dup is never stretched).

The CREG_CLK_DLL.STR_CONT bit defines if the clock stretch is in continuous or in precise mode. In either mode, the CLK_STRETCH pin is the stretch trigger.

- In continuous mode, as long as the CLK_STRETCH pin is high, every third PLL beat is skipped.
- In precise mode, a pulse on the CLK_STRETCH pin causes a single PLL beat to be skipped.
 - The exact PLL cycle depends on Tx (for example, J-div)
 - The CREG_CLK_DLL.STR_DLY bit allows sweeping of the stretch cycle.

10.1.1.7 Clock *n*-Step

You can issue a specific number of clocks at speed. which can be used for an automatic test pattern generation (ATPG) or a macro test capture cycle. Specifying the number of clocks:

- Can lock the PLL with a cold reset sequence
- Program *n*-step by way of the TAP
- Scan in a pattern (at TCK speed)
- Trigger the CTU to issue *n*-capture clocks (at full speed)
- Scan out result (at TCK speed)

10.1.1.8 Clock Signal Distribution

Clock signals distribution have the following characteristics:

- Clocks are generated in the PLL domain and are distributed as gclk.
- The C domain control signals are distributed through the flop repeaters.
- The repeaters on the gclk have an asynchronous reset.
- The D and J domain control signals are distributed point-to-point.
- A Cluster has one header per domain.
- The Cluster header does the clock gating, gclk -> rclk.
- *sync* and GRST_L have race-through synchronizer for gclk -> rclk.

[FIGURE 10-5](#) displays the clock signal distribution.

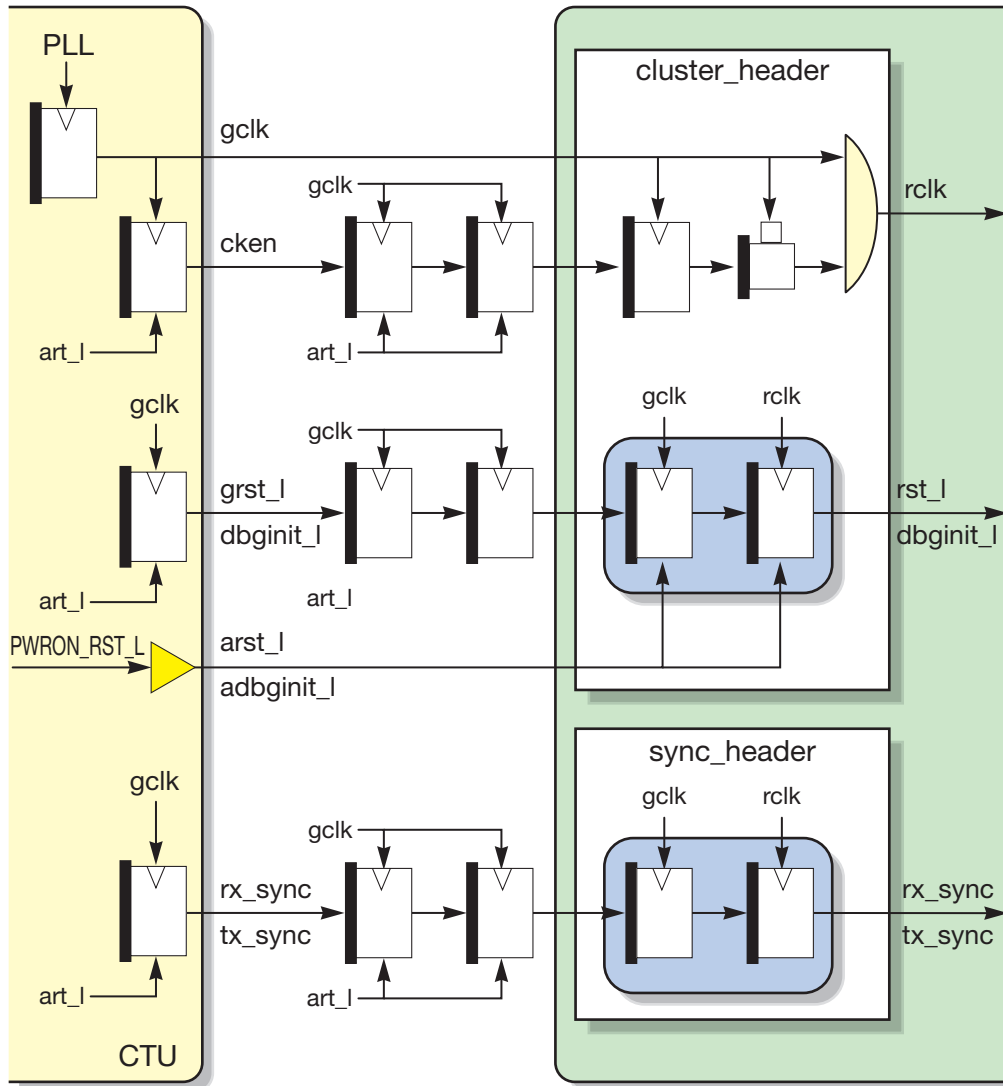

FIGURE 10-5 Clock Signal Distribution

10.1.2 OpenSPARC T1 Processor Resets

The resets of the OpenSPARC T1 processor have the following characteristics:

- There are three input reset signals:
 - Power-on reset (PWRON_RST_L)
 - JTAG test access port (TAP) reset (TRST_L)
 - J-Bus reset (J_RST_L)
- At power-on, the TRST_L and PWRON_RST_L resets must be asserted before applying power, then deasserted after power is stable.
- Deasserting the TRST_L reset completes TAP reset sequence.
- Generally, a TAP reset and a *function* reset are independent, but some things may need to be set up before the *function* reset is done.
- Deasserting the PWRON_RST_L reset proceeds with a cold sequence.
- The initial state of the J_RST_L reset is *don't care*, though the reset needs to assert and deassert to complete the sequence.
- In *system*, the initial state of the J_RST_L reset is asserted.
- In *tester*, the initial state of the J_RST_L reset is unasserted.
- The PWRON_RST_L reset is not always used asynchronously.
- The design guarantees that some clocks will propagate to PADs while the PWRON_RST_L reset is asserted.

10.1.2.1 Power-On Reset (PWRON_RST_L)

- Assertion of PWRON_RST_L reset causes:
 - All internal cluster resets to be asserted.
 - CREGs in the CTU to be set to their defaults.
 - All CKENs to be turned-off, except J domain PADs.
 - The C and D domain trees to be turned off, and the J and dup trees to be turned on.
 - The ARST_L to PLL is *unasserted*, allowing the PLL to toggle.
 - The J domain tree is fed from dup divider.
- Deassertion of PWRON_RST_L reset causes:
 - The asynchronous resets to be deasserted (the synchronous ones will remain asserted).
 - The initiation of PLL lock sequence.

10.1.2.2 J-Bus Reset (J_RST_L)

A J_RST_L reset assertion causes all cluster clocks to be turned on at the target frequencies.

- For a cold reset, the PLL is already locked.
 - In *system*, the J_RST_L reset should remain asserted until the PLL is locked.
 - In *tester*, the J_RST_L reset should assert after the PLL is locked.
- For a warm reset, a (real or fake) PLL re-lock sequence is done.
 - CKEN to all clusters are turned on.
 - The J_RST_L reset deassertion causes all synchronous resets to be deasserted, and the reset sequences to complete.

10.1.2.3 Reset Sequence

There are two types of reset sequences - a cold reset and a warm reset. While there are 10 generic steps in the reset sequence, and all 10 are done during a cold reset, steps 8 and 9 are not done in the warm reset.

These 10 generic reset sequence steps are described as:

1. Assert resets
 - a. Asynchronous resets – ARST_L and ADBGINIT_L
 - b. Synchronous resets – GRST_L and GDBGINIT_L
 - c. For cold resets, assertion of the PWRON_RST_L reset asserts all resets. Deassertion of the PWRON_RST_L reset deasserts only asynchronous ones, while the synchronous ones remain asserted.
 - d. For warm resets, only synchronous resets are asserted.
 - i. C and J domain resets are asserted about the same time
 - ii. For *fchg* and *warm* resets, CREG_CLK_CTL.SRARM defines whether the *rfsh* attribute is on or off
 - iii. If the *rfsh* is not on, the D domain reset is asserted at the same time
 - iv. If *rfsh* is on, the *self_refresh* signal to DRAM is asserted, and the D reset is asserted about 1600 ref cycles after C and J resets
2. Turn off clock enables
 - a. For cold resets, this *sequence* is instantaneous. Assertion of the PWRON_RST_L reset turns on clock enables for the PADS misc, jbusl, jbusr, dbg, and turns off all others

- b. For warm resets, the clock turn off is staggered
 - i. Starting cluster is 0 (for `sparc0`)
 - ii. Progression is in the `CREG_CLK_CTL` bit order
 - iii. The gap between clusters is defined by `CREG_CLK_CTL.STP_DLY`
 - iv. The default gap is 128 chip-level multiprocessor (CMP) clocks
 - v. The gap for the D and J domain clock enables is subject to `Tx_sync`.
- 3. Turn off clock trees
 - a. The C and D domain trees are stopped at the divider
 - b. The J and *dup* trees are never turned off
 - i. The J-div may be turned off, but then the J-tree is fed from j-dup
- 4. Establish PLL output
 - a. The PLL locking is sequenced by a simple SM on raw clocks
 - b. For a cold reset, the sequence is shown as:
 - i. PLL bypass mode – reset count = 128, lock count = 16
 - ii. PLL lock mode – reset count = 128, reset + lock = 32000 (for a cold reset)
 - c. For a frequency change reset, a similar sequence is used
 - d. For other warm resets, a *fake* sequence is used, where the PLL reset is not asserted and counters are shorter
- 5. Turn on clock trees
 - a. The C, D, and J domain dividers start in sync with J-dup, and the result is a common rising (AKA coincident) edge. (For cycle deterministic operation, tester/diagnostics tests must keep track of coincident edges.)
 - b. If the `JBUS_GCLK` was running from J-dup, it switches to J-div (in PLL bypass mode, `JBUS_GCLK` is not the same frequency as `J_CLK`)
- 6. Turn on clock enables
 - a. The cluster clock enables are turned-on in a staggered way
 - b. The starting cluster is 0 (for `sparc0`), and the enables progress in a `CREG` bit order
 - c. There is a gap of 129 CMP clocks between clusters
 - d. The D and J domain clock enables are subject to `Tx_sync`

7. Deassert resets
 - a. For cold resets, the ARST_L signals are already deasserted at the deassertion of the PWRON_RST_L reset
 - b. The GRST_L signals are deasserted at the same time in all domains
 - c. The DLL reset is deasserted a few cycles before the GRST_L deassertion
8. Transfer the e-Fuse cluster (EFC) data

Note – This step is only performed during a cold reset.

- a. The CTU kicks the EFC to start the data transfer
 - b. The EFC transfers device specific information such as SRAM repair information to the target clusters
 - c. *Core-available* information is programmed into the IOB, but it is still visible to the CTU
 - d. There is no handshake to indicate the end of the operation, and the CTU just waits a fixed number of cycles
9. Do BIST

Note – This step is only performed during a cold reset.

- a. At the J_RST_L reset deassert time, DO_BIST pin is sampled for eight cycles to determine the *msg*, which determines:
 - i. The DO_BIST pin tied low on *system*
 - ii. Do or do not perform a BIST action
 - iii. BIST vs. bi-directional schematic interface (BISI)
 - iv. Serial vs. parallel
 - b. If a BIST action is required, it occurs after the EFC is done
 - c. The CTU starts the BIST engines (enabled by EFC), and then the CTU waits for a response from the engines
 - d. The status from each BIST engine is recorded, but does not affect reset sequence
10. Send an interrupt to a thread in a core
 - a. The CTU activates a *wake-thread* signal to the IOB

- b. The IOB generates an interrupt packet to thread 0 of the lowest numbered SPARC core marked enabled
- c. The SPARC core starts fetching instructions from SSI interface

Cold Reset Sequence

A cold reset sequence has four steps:

1. Assertion of the PWRON_RST_L reset, which performs steps 1, 2, and 3 of the preceding generic reset sequence described in [Section 10.1.2.3, “Reset Sequence” on page 10-11](#).
2. Deassertion of the PWRON_RST_L reset, which performs step 4 of the generic reset sequence.
3. Assertion of the J_RST_L reset, which performs steps 5 and 6 of the generic reset sequence.
4. Deassertion of the J_RST_L reset, which performs the steps 7, 8, 9, and 10 of the generic reset sequence.

There are two types of the cold resets - normal and deterministic. The timing of the J_RST_L reset assertion determines the reset type. On the tester, the deterministic type is used.

Warm Reset Sequence

Warm reset sequence has only 2 steps, and during warm reset PWRON_RST_L remains unasserted throughout. The 2 steps are:

1. Assertion of the J_RST_L reset, which performs steps 1 through 6 of the preceding generic reset sequence described in [Section 10.1.2.3, “Reset Sequence” on page 10-11](#).
2. Deassertion of the J_RST_L reset, which performs steps 7 and 10 of the generic reset sequence (skipping steps 8 and 9).

The SPARC core initiates a warm reset by writing to the I/O bridge (IOB) chip in order to toggle the J_RST_L reset signal. A warm reset can be used for:

- Recovering from *hangs*
- Creating a deterministic diagnostics start
- Changing frequency

10.1.2.4 Debug Initialization

A debug unitization is a lightweight reset intended to create determinism with respect to a coincident edge.

- Software is required to achieve a quiescent state, and:
 - Stop all threads
 - Clear out arrays
- A read to the CREG_DBG_INIT causes the GDBGINIT_L signals to be asserted, and then deasserted
- Read data return occurs with a fixed relationship to a coincident edge

10.2 I/O Signal list

TABLE 10-2 describes the I/O signals for the OpenSPARC T1 processor clock and test unit (CTU).

TABLE 10-2 CTU I/O Signal List

Signal Name	I/O	Source/ Destination	Description
afi_pll_trst_l	In		PLL Test Reset
afi_tsr_mode	In		
io_j_clk[1:0]	In	PADS	J clock input from PADS
afi_bist_mode	In		To ctu_dft of ctu_dft.v
afi_bypass_mode	In		To ctu_dft of ctu_dft.v
afi_pll_char_mode	In		To ctu_dft of ctu_dft.v
afi_pll_clamp_ftr	In		To ctu_dft of ctu_dft.v
afi_pll_div2[5:0]	In		To ctu_dft of ctu_dft.v
afi_rng_ctl[2:0]	In		To ctu_dft of ctu_dft.v
afi_rt_addr_data	In		To ctu_dft of ctu_dft.v
afi_rt_data_in[31:0]	In		To ctu_dft of ctu_dft.v
afi_rt_high_low	In		To ctu_dft of ctu_dft.v
afi_rt_read_write	In		To ctu_dft of ctu_dft.v
afi_rt_valid	In		To ctu_dft of ctu_dft.v

TABLE 10-2 CTU I/O Signal List (*Continued*)

Signal Name	I/O	Source/ Destination	Description
afi_tsr_div[9:1]	In		To ctu_dft of ctu_dft.v
afi_tsr_tsel[7:0]	In		To ctu_dft of ctu_dft.v
cmp_gclk	In		To u_cmp_header of bw_clk_cl_ctu_cmp.v
cmp_gclk_cts	In		To u_cmp_gclk_dr of bw_u1_ckbuf_40x.v
ddr0_ctu_dll_lock	In	PADS	To ctu_clsp of ctu_clsp.v
ddr0_ctu_dll_overflow	In	PADS	To ctu_clsp of ctu_clsp.v
ddr1_ctu_dll_lock	In	PADS	To ctu_clsp of ctu_clsp.v
ddr1_ctu_dll_overflow	In	PADS	To ctu_clsp of ctu_clsp.v
ddr2_ctu_dll_lock	In	PADS	To ctu_clsp of ctu_clsp.v
ddr2_ctu_dll_overflow	In	PADS	To ctu_clsp of ctu_clsp.v
ddr3_ctu_dll_lock	In	PADS	To ctu_clsp of ctu_clsp.v
ddr3_ctu_dll_overflow	In	PADS	To ctu_clsp of ctu_clsp.v
dll0_ctu_ctrl[4:0]	In	PADS	To ctu_clsp of ctu_clsp.v
dll1_ctu_ctrl[4:0]	In	PADS	To ctu_clsp of ctu_clsp.v
dll2_ctu_ctrl[4:0]	In	PADS	To ctu_clsp of ctu_clsp.v
dll3_ctu_ctrl[4:0]	In	PADS	To ctu_clsp of ctu_clsp.v
dram02_ctu_tr	In	DRAM	DRAM debug trigger
dram13_ctu_tr	In	DRAM	DRAM debug trigger
dram_gclk_cts	In	DRAM	To u_dram_gclk_dr of bw_u1_ckbuf_30x.v
efc_ctu_data_out	In	EFC	To ctu_dft of ctu_dft.v
io_clk_stretch	In	PADS	To ctu_clsp of ctu_clsp.v
io_do_bist	In	PADS	To ctu_clsp of ctu_clsp.v
io_j_rst_1	In	PADS	To ctu_clsp of ctu_clsp.v
io_pll_char_in	In	PADS	To ctu_clsp of ctu_clsp.v, and so on
io_pwron_rst_1	In	PADS	To ctu_clsp of ctu_clsp.v, and so on
io_tck	In	PADS	To u_tck_dr of bw_u1_ckbuf_30x.v, and so on
io_tck2	In	PADS	To ctu_clsp of ctu_clsp.v
io_tdi	In	PADS	To ctu_dft of ctu_dft.v
io_test_mode	In	PADS	To ctu_dft of ctu_dft.v
io_tms	In	PADS	To ctu_dft of ctu_dft.v

TABLE 10-2 CTU I/O Signal List (*Continued*)

Signal Name	I/O	Source/ Destination	Description
io_trst_l	In	PADS	To ctu_dft of ctu_dft.v
io_vdda_pll	In	PADS	To u_pll of bw_pll.v
io_vdda_rng	In	PADS	To u_rng of bw_rng.v
io_vdda_tsr	In	PADS	To u_tsr of bw_tsr.v
io_vreg_selbg_l	In	PADS	To u_rng of bw_rng.v
iob_clsp_data[3:0]	In	IOB	To ctu_clsp of ctu_clsp.v
iob_clsp_stall	In	IOB	To ctu_clsp of ctu_clsp.v
iob_clsp_vld	In	IOB	To ctu_clsp of ctu_clsp.v
iob_ctu_coreavail[7:0]	In	IOB	To ctu_dft of ctu_dft.v
iob_ctu_l2_tr	In	IOB	To ctu_clsp of ctu_clsp.v
iob_ctu_tr	In	IOB	To ctu_clsp of ctu_clsp.v
iob_tap_data[7:0]	In	IOB	To ctu_dft of ctu_dft.v
iob_tap_stall	In	IOB	To ctu_dft of ctu_dft.v
iob_tap_vld	In	IOB	To ctu_dft of ctu_dft.v
jbi_ctu_tr	In	JBI	To ctu_clsp of ctu_clsp.v
jbus_gclk	In	JBI	To u_jbus_header of bw_clk_cl_ctu_jbus.v
jbus_gclk_cts	In	JBI	To u_jbus_gclk_dr of bw_u1_ckbuf_30x.v
jbus_gclk_dup	In	JBI	To u_pll of bw_pll.v
jbus_grst_l	In	JBI	To u_jbus_header of bw_clk_cl_ctu_jbus.v
pads_ctu_bsi	In	PADS	To ctu_dft of ctu_dft.v
pads_ctu_si	In	PADS	To ctu_dft of ctu_dft.v
sctag0_ctu_mbistdone	In	SCTAG0	MBIST done
sctag0_ctu_mbisterr	In	SCTAG0	MBIST error
sctag0_ctu_tr	In	SCTAG0	SCTAG debug trigger
sctag1_ctu_mbistdone	In	SCTAG1	MBIST done
sctag1_ctu_mbisterr	In	SCTAG1	MBIST error
sctag1_ctu_tr	In	SCTAG1	SCTAG debug trigger
sctag2_ctu_mbistdone	In	SCTAG2	MBIST done
sctag2_ctu_mbisterr	In	SCTAG2	MBIST error
sctag2_ctu_serial_scan_in	In	SCTAG2	Scan In

TABLE 10-2 CTU I/O Signal List (*Continued*)

Signal Name	I/O	Source/ Destination	Description
sctag2_ctu_tr	In	SCTAG2	SCTAG debug trigger
sctag3_ctu_mbistdone	In	SCTAG3	MBIST done
sctag3_ctu_mbisterr	In	SCTAG3	MBIST error
sctag3_ctu_tr	In	SCTAG3	SCTAG debug trigger
spc0_ctu_mbistdone	In	SPARC0	MBIST done
spc0_ctu_mbisterr	In	SPARC0	MBIST error
spc0_ctu_sscan_out	In	SPARC0	Scan out from SPARC
spc1_ctu_mbistdone	In	SPARC1	MBIST done
spc1_ctu_mbisterr	In	SPARC1	MBIST error
spc1_ctu_sscan_out	In	SPARC1	Scan out from SPARC
spc2_ctu_mbistdone	In	SPARC2	MBIST done
spc2_ctu_mbisterr	In	SPARC2	MBIST error
spc2_ctu_sscan_out	In	SPARC2	Scan Out from SPARC
spc3_ctu_mbistdone	In	SPARC3	MBIST done
spc3_ctu_mbisterr	In	SPARC3	MBIST error
spc3_ctu_sscan_out	In	SPARC3	Scan Out from SPARC
spc4_ctu_mbistdone	In	SPARC4	MBIST done
spc4_ctu_mbisterr	In	SPARC4	MBIST error
spc4_ctu_sscan_out	In	SPARC4	Scan Out from SPARC
spc5_ctu_mbistdone	In	SPARC5	MBIST done
spc5_ctu_mbisterr	In	SPARC5	MBIST error
spc5_ctu_sscan_out	In	SPARC5	Scan Out from SPARC
spc6_ctu_mbistdone	In	SPARC6	MBIST done
spc6_ctu_mbisterr	In	SPARC6	MBIST error
spc6_ctu_sscan_out	In	SPARC6	Scan Out from SPARC
spc7_ctu_mbistdone	In	SPARC7	MBIST done
spc7_ctu_mbisterr	In	SPARC7	MBIST error
spc7_ctu_sscan_out	In	SPARC7	Scan Out from SPARC
data	In		
lclk	In		

TABLE 10-2 CTU I/O Signal List (*Continued*)

Signal Name	I/O	Source/ Destination	Description
rclk	In		
enable_chk	In		
ctu_tst_pre_grst_l	Out		
global_shift_enable	Out		From ctu_dft of ctu_dft.v
ctu_tst_scanmode	Out		From ctu_dft of ctu_dft.v
ctu_tst_macrotest	Out		From ctu_dft of ctu_dft.v
ctu_tst_short_chain	Out		From ctu_dft of ctu_dft.v
ctu_efc_read_start	Out	EFC	
ctu_jbi_ssiclk	Out	JBI	
ctu_dram_rx_sync_out	Out	DRAM	From ctu_clsp of ctu_clsp.v
ctu_dram_tx_sync_out	Out	DRAM	From ctu_clsp of ctu_clsp.v
ctu_jbus_rx_sync_out	Out	JBI	From ctu_clsp of ctu_clsp.v
ctu_jbus_tx_sync_out	Out	JBI	From ctu_clsp of ctu_clsp.v
cmp_grst_out_l	Out		From ctu_clsp of ctu_clsp.v
afo_rng_clk	Out		From u_rng of bw_rng.v
afo_rng_data	Out		From u_rng of bw_rng.v
afo_rt_ack	Out		From ctu_dft of ctu_dft.v
afo_rt_data_out[31:0]	Out		From ctu_dft of ctu_dft.v
afo_tsr_dout[7:0]	Out		From u_tsr of bw_tsr.v
clsp_iob_data[3:0]	Out		From ctu_clsp of ctu_clsp.v
clsp_iob_stall	Out	IOB	From ctu_clsp of ctu_clsp.v
clsp_iob_vld	Out	IOB	From ctu_clsp of ctu_clsp.v
cmp_adbginit_l	Out		From ctu_clsp of ctu_clsp.v
cmp_arst_l	Out		From ctu_clsp of ctu_clsp.v
cmp_gclk_out	Out		From ctu_clsp of ctu_clsp.v
cmp_gdbginit_out_l	Out		From ctu_clsp of ctu_clsp.v
ctu_ccx_cmp_cken	Out		From ctu_clsp of ctu_clsp.v
ctu_dbg_jbus_cken	Out		From ctu_clsp of ctu_clsp.v
ctu_ddr0_clock_dr	Out	PADS	From ctu_dft of ctu_dft.v
ctu_ddr0_dll_delayctr[2:0]	Out	PADS	From ctu_clsp of ctu_clsp.v

TABLE 10-2 CTU I/O Signal List (*Continued*)

Signal Name	I/O	Source/ Destination	Description
ctu_ddr0_dram_cken	Out	PADS	From ctu_clsp of ctu_clsp.v
ctu_ddr0_hiz_l	Out	PADS	From ctu_dft of ctu_dft.v
ctu_ddr0_iodll_rst_l	Out	PADS	From u_ctu_ddr0_iodll_rst_l_or2_ecobug of ctu_or2.v
ctu_ddr0_mode_ctl	Out	PADS	From ctu_dft of ctu_dft.v
ctu_ddr0_shift_dr	Out	PADS	From ctu_dft of ctu_dft.v
ctu_ddr0_update_dr	Out	PADS	From ctu_dft of ctu_dft.v
ctu_ddr1_clock_dr	Out	PADS	From ctu_dft of ctu_dft.v
ctu_ddr1_dll_delayctr[2:0]	Out	PADS	From ctu_clsp of ctu_clsp.v
ctu_ddr1_dram_cken	Out	PADS	From ctu_clsp of ctu_clsp.v
ctu_ddr1_hiz_l	Out	PADS	From ctu_dft of ctu_dft.v
ctu_ddr1_iodll_rst_l	Out	PADS	From u_ctu_ddr1_iodll_rst_l_or2_ecobug of ctu_or2.v
ctu_ddr1_mode_ctl	Out	PADS	From ctu_dft of ctu_dft.v
ctu_ddr1_shift_dr	Out	PADS	From ctu_dft of ctu_dft.v
ctu_ddr1_update_dr	Out	PADS	From ctu_dft of ctu_dft.v
ctu_ddr2_clock_dr	Out	PADS	From ctu_dft of ctu_dft.v
ctu_ddr2_dll_delayctr[2:0]	Out	PADS	From ctu_clsp of ctu_clsp.v
ctu_ddr2_dram_cken	Out	PADS	From ctu_clsp of ctu_clsp.v
ctu_ddr2_hiz_l	Out	PADS	From ctu_dft of ctu_dft.v
ctu_ddr2_iodll_rst_l	Out	PADS	From u_ctu_ddr2_iodll_rst_l_or2_ecobug of ctu_or2.v
ctu_ddr2_mode_ctl	Out	PADS	From ctu_dft of ctu_dft.v
ctu_ddr2_shift_dr	Out	PADS	From ctu_dft of ctu_dft.v
ctu_ddr2_update_dr	Out	PADS	From ctu_dft of ctu_dft.v
ctu_ddr3_clock_dr	Out	PADS	From ctu_dft of ctu_dft.v
ctu_ddr3_dll_delayctr[2:0]	Out	PADS	From ctu_clsp of ctu_clsp.v
ctu_ddr3_dram_cken	Out	PADS	From ctu_clsp of ctu_clsp.v
ctu_ddr3_hiz_l	Out	PADS	From ctu_dft of ctu_dft.v
ctu_ddr3_iodll_rst_l	Out	PADS	From u_ctu_ddr3_iodll_rst_l_or2_ecobug of ctu_or2.v
ctu_ddr3_mode_ctl	Out	PADS	From ctu_dft of ctu_dft.v
ctu_ddr3_shift_dr	Out	PADS	From ctu_dft of ctu_dft.v
ctu_ddr3_update_dr	Out	PADS	From ctu_dft of ctu_dft.v

TABLE 10-2 CTU I/O Signal List (*Continued*)

Signal Name	I/O	Source/ Destination	Description
ctu_ddr_testmode_l	Out	PADS	From ctu_dft of ctu_dft.v
ctu_debug_clock_dr	Out	PADS	From ctu_dft of ctu_dft.v
ctu_debug_hiz_l	Out	PADS	From ctu_dft of ctu_dft.v
ctu_debug_mode_ctl	Out	PADS	From ctu_dft of ctu_dft.v
ctu_debug_shift_dr	Out	PADS	From ctu_dft of ctu_dft.v
ctu_debug_update_dr	Out	PADS	From ctu_dft of ctu_dft.v
ctu_dll0_byp_l	Out		From ctu_clsp of ctu_clsp.v
ctu_dll0_byp_val[4:0]	Out		From ctu_clsp of ctu_clsp.v
ctu_dll1_byp_l	Out		From ctu_clsp of ctu_clsp.v
ctu_dll1_byp_val[4:0]	Out		From ctu_clsp of ctu_clsp.v
ctu_dll2_byp_l	Out		From ctu_clsp of ctu_clsp.v
ctu_dll2_byp_val[4:0]	Out		From ctu_clsp of ctu_clsp.v
ctu_dll3_byp_l	Out		From ctu_clsp of ctu_clsp.v
ctu_dll3_byp_val[4:0]	Out		From ctu_clsp of ctu_clsp.v
ctu_dram02_cmp_cken	Out	DRAM	From ctu_clsp of ctu_clsp.v
ctu_dram02_dram_cken	Out	DRAM	From ctu_clsp of ctu_clsp.v
ctu_dram02_jbus_cken	Out	DRAM	From ctu_clsp of ctu_clsp.v
ctu_dram13_cmp_cken	Out	DRAM	From ctu_clsp of ctu_clsp.v
ctu_dram13_dram_cken	Out	DRAM	From ctu_clsp of ctu_clsp.v
ctu_dram13_jbus_cken	Out	DRAM	From ctu_clsp of ctu_clsp.v
ctu_dram_selfrsh	Out	DRAM	From ctu_clsp of ctu_clsp.v
ctu_efc_capturedr	Out	EFC	From ctu_dft of ctu_dft.v
ctu_efc_coladdr[4:0]	Out	EFC	From ctu_dft of ctu_dft.v
ctu_efc_data_in	Out	EFC	From ctu_dft of ctu_dft.v
ctu_efc_dest_sample	Out	EFC	From ctu_dft of ctu_dft.v
ctu_efc_fuse_bypass	Out	EFC	From ctu_dft of ctu_dft.v
ctu_efc_jbus_cken	Out	EFC	From ctu_clsp of ctu_clsp.v
ctu_efc_read_en	Out	EFC	From ctu_dft of ctu_dft.v
ctu_efc_read_mode[2:0]	Out	EFC	From ctu_dft of ctu_dft.v
ctu_efc_rowaddr[6:0]	Out	EFC	From ctu_dft of ctu_dft.v

TABLE 10-2 CTU I/O Signal List (*Continued*)

Signal Name	I/O	Source/ Destination	Description
ctu_efc_shiftdr	Out	EFC	From ctu_dft of ctu_dft.v
ctu_efc_tck	Out	EFC	From ctu_dft of ctu_dft.v
ctu_efc_updatedr	Out	EFC	From ctu_dft of ctu_dft.v
ctu_fpu_cmp_cken	Out	FPU	From ctu_clsp of ctu_clsp.v
ctu_fpu_so	Out	FPU	From ctu_dft of ctu_dft.v
ctu_global_snap	Out		From ctu_dft of ctu_dft.v
ctu_io_clkobs[1:0]	Out	PADS	From u_pll of bw_pll.v
ctu_io_j_err	Out	PADS	From ctu_clsp of ctu_clsp.v
ctu_io_tdo	Out	PADS	From u_test_stub of ctu_test_stub_scan.v
ctu_io_tdo_en	Out	PADS	From ctu_dft of ctu_dft.v
ctu_io_tsr_testio[1:0]	Out	PADS	From u_tsr of bw_tsr.v
ctu_iob_cmp_cken	Out	IOB	From ctu_clsp of ctu_clsp.v
ctu_iob_jbus_cken	Out	IOB	From ctu_clsp of ctu_clsp.v
ctu_iob_resetstat[2:0]	Out	IOB	From ctu_clsp of ctu_clsp.v
ctu_iob_resetstat_wr	Out	IOB	From ctu_clsp of ctu_clsp.v
ctu_iob_wake_thr	Out	IOB	From ctu_clsp of ctu_clsp.v
ctu_jbi_cmp_cken	Out	JBI	From ctu_clsp of ctu_clsp.v
ctu_jbi_jbus_cken	Out	JBI	From ctu_clsp of ctu_clsp.v
ctu_jbusl_clock_dr	Out	PADS	From ctu_dft of ctu_dft.v
ctu_jbusl_hiz_l	Out	PADS	From ctu_dft of ctu_dft.v
ctu_jbusl_jbus_cken	Out	PADS	From ctu_clsp of ctu_clsp.v
ctu_jbusl_mode_ctl	Out	PADS	From ctu_dft of ctu_dft.v
ctu_jbusl_shift_dr	Out	PADS	From ctu_dft of ctu_dft.v
ctu_jbusl_update_dr	Out	PADS	From ctu_dft of ctu_dft.v
ctu_jbusr_clock_dr	Out	PADS	From ctu_dft of ctu_dft.v
ctu_jbusr_hiz_l	Out	PADS	From ctu_dft of ctu_dft.v
ctu_jbusr_jbus_cken	Out	PADS	From ctu_clsp of ctu_clsp.v
ctu_jbusr_mode_ctl	Out	PADS	From ctu_dft of ctu_dft.v
ctu_jbusr_shift_dr	Out	PADS	From ctu_dft of ctu_dft.v
ctu_jbusr_update_dr	Out	PADS	From ctu_dft of ctu_dft.v

TABLE 10-2 CTU I/O Signal List (*Continued*)

Signal Name	I/O	Source/ Destination	Description
ctu_misc_clock_dr	Out	PADS	From ctu_dft of ctu_dft.v
ctu_misc_hiz_l	Out	PADS	From ctu_dft of ctu_dft.v
ctu_misc_jbus_cken	Out	PADS	From ctu_clsp of ctu_clsp.v
ctu_misc_mode_ctl	Out	PADS	From ctu_dft of ctu_dft.v
ctu_misc_shift_dr	Out	PADS	From ctu_dft of ctu_dft.v
ctu_misc_update_dr	Out	PADS	From ctu_dft of ctu_dft.v
ctu_pads_bso	Out	PADS	From ctu_dft of ctu_dft.v
ctu_pads_so	Out	PADS	From ctu_dft of ctu_dft.v
ctu_pads_sscan_update	Out	PADS	From ctu_dft of ctu_dft.v
ctu_scddata0_cmp_cken	Out	SCDATA0	Clock enable
ctu_scddata1_cmp_cken	Out	SCDATA1	Clock enable
ctu_scddata2_cmp_cken	Out	SCDATA2	Clock enable
ctu_scddata3_cmp_cken	Out	SCDATA3	Clock enable
ctu_sctag0_cmp_cken	Out	SCTAG0	Clock enable
ctu_sctag0_mbisten	Out	SCTAG0	MBIST enable
ctu_sctag1_cmp_cken	Out	SCTAG1	Clock enable
ctu_sctag1_mbisten	Out	SCTAG1	MBIST enable
ctu_sctag2_cmp_cken	Out	SCTAG2	Clock enable
ctu_sctag2_mbisten	Out	SCTAG2	MBIST enable
ctu_sctag3_cmp_cken	Out	SCTAG3	Clock enable
ctu_sctag3_mbisten	Out	SCTAG3	MBIST enable
ctu_spc0_cmp_cken	Out	SPARC0	Clock enable
ctu_spc0_mbisten	Out	SPARC0	MBIST enable
ctu_spc0_sscan_se	Out	SPARC0	Shadow scan enable
ctu_spc0_tck	Out	SPARC0	Test clock
ctu_spc1_cmp_cken	Out	SPARC1	Clock enable
ctu_spc1_mbisten	Out	SPARC1	MBIST enable
ctu_spc1_sscan_se	Out	SPARC1	Shadow scan enable
ctu_spc1_tck	Out	SPARC1	Test clock
ctu_spc2_cmp_cken	Out	SPARC2	Clock enable

TABLE 10-2 CTU I/O Signal List (*Continued*)

Signal Name	I/O	Source/ Destination	Description
ctu_spc2_mbisten	Out	SPARC2	MBIST enable
ctu_spc2_sscan_se	Out	SPARC2	Shadow scan enable
ctu_spc2_tck	Out	SPARC2	Test clock
ctu_spc3_cmp_cken	Out	SPARC3	Clock enable
ctu_spc3_mbisten	Out	SPARC3	MBIST enable
ctu_spc3_sscan_se	Out	SPARC3	Shadow scan enable
ctu_spc3_tck	Out	SPARC3	Test clock
ctu_spc4_cmp_cken	Out	SPARC4	Clock enable
ctu_spc4_mbisten	Out	SPARC4	MBIST enable
ctu_spc4_sscan_se	Out	SPARC4	Shadow scan enable
ctu_spc4_tck	Out	SPARC4	Test clock
ctu_spc5_cmp_cken	Out	SPARC5	Clock enable
ctu_spc5_mbisten	Out	SPARC5	MBIST enable
ctu_spc5_sscan_se	Out	SPARC5	Shadow scan enable
ctu_spc5_tck	Out	SPARC5	Test clock
ctu_spc6_cmp_cken	Out	SPARC6	Clock enable
ctu_spc6_mbisten	Out	SPARC6	MBIST enable
ctu_spc6_sscan_se	Out	SPARC6	Shadow scan enable
ctu_spc6_tck	Out	SPARC6	Test clock
ctu_spc7_cmp_cken	Out	SPARC7	Clock enable
ctu_spc7_mbisten	Out	SPARC7	MBIST enable
ctu_spc7_sscan_se	Out	SPARC7	Shadow scan enable
ctu_spc7_tck	Out	SPARC7	Test clock
ctu_spc_const_maskid[7:0]	Out	SPARC	Mask ID
ctu_spc_sscan_tid[3:0]	Out	SPARC	
ctu_tst_scan_disable	Out		
dram_adbginit_l	Out	DRAM	Asynchronous Reset
dram_arst_l	Out	DRAM	Asynchronous Reset
dram_gclk_out	Out	DRAM	Clock
dram_gdbginit_out_l	Out	DRAM	Synchronous Reset

TABLE 10-2 CTU I/O Signal List (*Continued*)

Signal Name	I/O	Source/ Destination	Description
dram_grst_out_1	Out	DRAM	Synchronous Reset
global_scan_bypass_en	Out		
jbus_adbginit_1	Out	JBI	Asynchronous Reset
jbus_arst_1	Out	JBI	Asynchronous Reset
jbus_gclk_dup_out	Out	JBI	Clock
jbus_gclk_out	Out	JBI	Clock
jbus_gdbginit_out_1	Out	JBI	Synchronous Reset
jbus_grst_out_1	Out	JBI	Synchronous Reset
pscan_select	Out		
tap_iob_data[7:0]	Out	IOB	
tap_iob_stall	Out	IOB	
tap_iob_vld	Out	IOB	

