

On-Site Wastewater Disposal System

For

Touba Residence

Site

10300 Derecho Drive
16.00 Acres out of the
William P. Baxter Survey Abs. 118
Austin, Texas
Travis County

Permit #

An Aerobic OSSF with Spray Irrigation Disposal Field
for a
6-Bedroom Home
of
3,863 sq. ft.

Design By:

Brandon L. Couch, R.S.
2314 Rock Ledge Drive
Georgetown, Texas 78626
(512) 630-8600

November 30, 2009

Permit #

Design Calculation & Notes

For 10300 Derecho Drive

System Destination:

Owner/Client: Nur & Martha Touba

Location: 10300 Derecho Drive, 16.00 Ac. out of the Wm. P. Baxter Survey Abs. 118, Austin

Permit #

Minimum design capacity for a 6-bedroom home with water-saving devices

Estimated daily flow 420 GPD

Inspection Schedule:

Inspection schedule must be adhered to in order to demonstrate compliance. This schedule is independent of the local health authority's inspection & requirements.

Pre-construction Meeting: Meet with designer prior to construction with any questions.

Plumbing Inspection: Plumbing, pump, controls, and alarm are in place, operational and exposed.

Final: When system is complete and landscaping is finished.

Proposed System:

Install an aerobic pre-treatment/chlorination system with a spray irrigation type drainfield on this site. The aerobic unit must be NSF approved and meet all state and local requirements for effluent quality.

Selection Criteria:

System selected due to shallow soil conditions. Surface soils are sufficient to support vegetation; exposed rocks should be covered with 4" of dirt or removed.

Design Ideology:

Primary treatment of effluent will be accomplished using a NSF approved aerobic treatment unit with secondary quality polished with a tablet chlorinator for disinfection. Treated effluent will then be distributed evenly over the disposal field area at night. Spray irrigation will be the method of effluent dispersal and disposal. **There are no recharge features within 150' of the disposal area.**

Drain Field Calculations:

The designed load for this system is 420 GPD

Spray irrigation requires $420/.064$ or 6562.5 sq. ft. field area

- a) Field Area = 6870.66 sq. ft.
- b) Impact Sprinkler Heads = 3
- c) Coverage area/head = 2290.22 sq. ft./head (avg)
- d) Impact setting
Set heads at no more than 30 PSI, utilizing $3(27^2 \times \pi)$
= 6870.66 sq. ft.
- e) Minimum spacing of heads = 3 @ 54" apart (see site plan)
- f) Flow (GPM)/field = 3 x 3.4 GPM = 10.2 GPM
- g) Total Daily Irrigation Time = 420 GPD/10.2 GPM = 42 minutes/day
- h) Aerobic treatment system = Jet (J-750) including: Aerobic unit, Aerator mechanism, Electronic controls in a weatherproof box.
- i) Filter = In-Line 100 micron mesh screen filter, API API4E-100 (1") with return to pump tank.
- j) Chlorinator = Tablet chlorinator (sensor optional)*Use calcium hypochlorite tablets
- k) Pressure Gauge = A pressure gauge/gate valve will be installed to regulate flow to spray heads for a pressure setting of not less than 45 PSI at pump (30 PSI at heads).
- l) Collection port = A unthreaded hose bib or equivalent shall be installed in the pump chamber to facilitate sampling of effluent on a periodic basis.

Permit #

m) Irrigation heads = Shuttle zinc pop-up gear-driven head with ½” inlet and distance adjustment (Hunter PGP-ARV-with #8 low angle, low misting nozzles) purple tops, & low head flapper check valves

***Important Installer Note: Wastewater gases are corrosive. Do not use components in the pump tank that are subject to oxidation such as metal clamps, brass fittings, or hose bibs, etc. as they will deteriorate. Use plastic binders, PVC fittings, etc. Use airtight seals on electric splices in the pump tank if any. Be sure to silicone seal any route by which chlorine gas might reach control panels such as electrical conduits from the pump tank. IN CASES OF SHALLOW GROUNDWATER, BE SURE TO SET TANKS AS SHALLOW AS POSSIBLE AND SILICONE SEAL ALL JOINTS AND AROUND THE TANK LID TO PREVENT SEEPAGE.**

Pump Timer

A NSF approved, night actuated control panel is also acceptable.
Set for 2 a.m. application.

Tank Data:

Trash tank: 500-gallon compartment (concrete)
Pre-treatment tank: Jet J-750 aerobic unit (capacity 7500gpd)
Pump tank: 1250 gallon Buchanan single compartment (concrete)

Installation Note: Tanks are to be installed with a minimum separation of five feet from the foundation. The tank is to be level (+/- 1”) and is to be set on a minimum of four inches of washed sand. A clean-out shall be installed between foundation and septic tank or every 50’. 1/8” fall per foot min; 4” SCH 40 PVC.

Pump Tank Data:

A single compartment 1250-gallon concrete tank shall be used as the pump chamber.

Inlet @ 39” above the floor (outlet sealed, pump through top port)
Volume per inch = 34.72 gallons/inch
Minimum 420 gallons of pump flow above alarm = $420/34.72 = \approx 12.5$ ” volume
Alarm on at 26.5 inches above the floor (leaving 434 gallons for alarm volume)
Start Pump @ 14 inches above the floor
Stop Pump @ 14 inches above the floor

Alarm System:

An audio/visual high water alarm (red light) will be installed on this system. RJR Control Panel (ACP-JT) or equal. The alarm/light will be installed in a highly visible location as near the pump tank as possible. Alarm and pump on separate circuits. Use of disinfection alarm encouraged if system to be chlorinated. A tonedialer may be used to optionally notify the maintenance company of alarm codes (add FAILSAFE to controller).

NOTE TO BUILDER: Please be sure to run power & phone to control panel area.

Drain Field Data:

The disposal area will be comprised of 1 field. Field area shall contain 3 pop-up gear-driven sprinkler heads. The sprinkler heads shall be spaced a minimum of 54” apart. The heads will be connected to the system with 1” SCH 40 PVC *permanently colored purple* supply line with an in-line filter of 100 micron mesh. Sprinkler heads shall be adjusted so that angle of spray is no higher than 13 degrees.

Disposal Field Finish:

1. The sprinkler system area shall be located in a relatively open area at *least 100’ away from any well, 25’ from any property line, & 10’ from drainage easement. Spray heads to be 10’ from any obstacle.*
2. *Heads must be out of 10’ from any waterline.*
3. Any exposed rock shall be covered prior to operation with 4” suitable soil or removed.
4. The field area must be seeded, hydromulched, or sodded immediately after installation.
5. The field shall be maintained at all times (mowed).

Pump Data:

Design Goals: Provide 10.2 GPM to 3 gear-driven sprinkler heads at 30 PSI.

Tank depth (7') + Elevation to field (-12) = total elevation	-5.00'
Fluid at 30 PSI =	69.30'
Friction for 275' pipe, meter, filter, and fittings	+37.43'
Total head pressure	101.73' (45 PSI)

Pump Selection: RedJacket E518 18GPM 1¼" discharge submersible pump, ½ hp, 115 volt, 60 Hz, or pump capable of attaining 40+ psi

Construction Notes:

- Installer shall be responsible to comply with TCEQ and local codes for proper OSSF installation.
- The owner or contractor is to be responsible for identifying all property lines, easements, wells and other related improvements either actual or proposed and verify that the septic system installation does not violate any regulation or law. Water lines shall be a minimum of 10' from any OSSF drainfield.
- All roof and surface drainage shall be diverted from fields by guttering, berms, swales, etc.
- It is required that water conserving methods be used with this system, including low flush toilets (1.6 gallons), pressure reducing faucet aerators and shower heads to reduce overloading the field areas.
- Should seepage or other underground water be found that was not found in the examination of the profile hole, stop all construction and notify the design engineer and/or the environmental permitting agency.
- Homeowner/contractor is hereby aware that it is illegal to allow water softeners to discharge into this treatment unit. It will cause corrosion of the electrical components, will shorten the life of the pumps and floats, and will void equipment warranties. Softener discharge may be routed to pump chamber as long as a demand initiated regeneration (DIR) controller is used.
- Liquid input into this septic system shall not exceed **420** gallons per day.

Note: This design in no way constitutes a warranty, extension of warranty, and/or guarantee of system operation or function. Owner is ultimately responsible for the system upkeep (retaining maintenance, reporting problems, monitoring flow, etc.). While the designer has made diligent effort to preserve vegetation and the landscape, the designer is not responsible for any losses (trees, landscaping, etc.) due to installation, operation, and/or system failure.

Design Maintenance and Limitations:

This OSSF design is intended to meet minimum state requirements for OSSF as of 9/11/2008. The owner should be aware that a septic system is a system of "limited" capacity and will not stand up to prolonged abuse. Any of the guidelines below which are not followed amount to abuse of the septic system constitutes agreement by the homeowner to regulate use of this system so as to maintain its integrity.

The owner is to be responsible for properly maintaining this aerobic system.

To keep your aerobic sewage system in peak condition the following steps should be taken:

- Keep the field areas mowed and in good condition in order to encourage peak transpiration.
- Do not allow excess water to enter your drainfield (sprinkler systems, run-off, etc) Leaky faucets and toilets must be repaired immediately.
- Avoid the use of garbage disposals to dispose of kitchen waste.
- The property owner must not use any additives to septic tanks, i.e., commercial enzymes, yeast, etc. Do not let harsh chemicals, grease, high sudsing detergents, discharge from water softeners, disinfectants or any other bactericides enter the system. **This is an aerobic "living" system, and additives can upset the natural bacterial balance.**
- Avoid flushing paper products or items not intended for septic use (i.e. toilet paper only).

- Be sure to pump out your trash tank (see schematic drawing) every 2 to 3 years to avoid excessive sludge build-up. Excessive build up reduces storage volume in your tank and can damage your drainfield.
- Do not allow vehicles or heavy equipment to drive over the irrigation fields or tanks.
- If any problem persists, such as frequent high water alarms or surfacing of septic water in your yard, call you OSFF service maintenance company for consultation or repair service.
- **Important!! The homeowner must leave the aerator for the aerobic unit running at all times.**

Information about Your Professional Maintenance Contract:

Homeowners with aerobic sewage systems are required by rule to maintain a “service” agreement. Your installer is to include an initial 2-year service agreement in the construction bid. The service agreement shall indicate at least 1 inspection every 4 months and inspections shall provide service as recommended by the aerobic unit manufacturer and/or as required by the licensing authority and must include remote monitoring. A written inspection report is to be issued to the owner and the licensing authority for each inspection performed.

If there is any question as to the implementation of these plans or any contemplation toward making significant changes to implement installation, contact the designer-
Brandon L. Couch R.S. (512) 630-8600

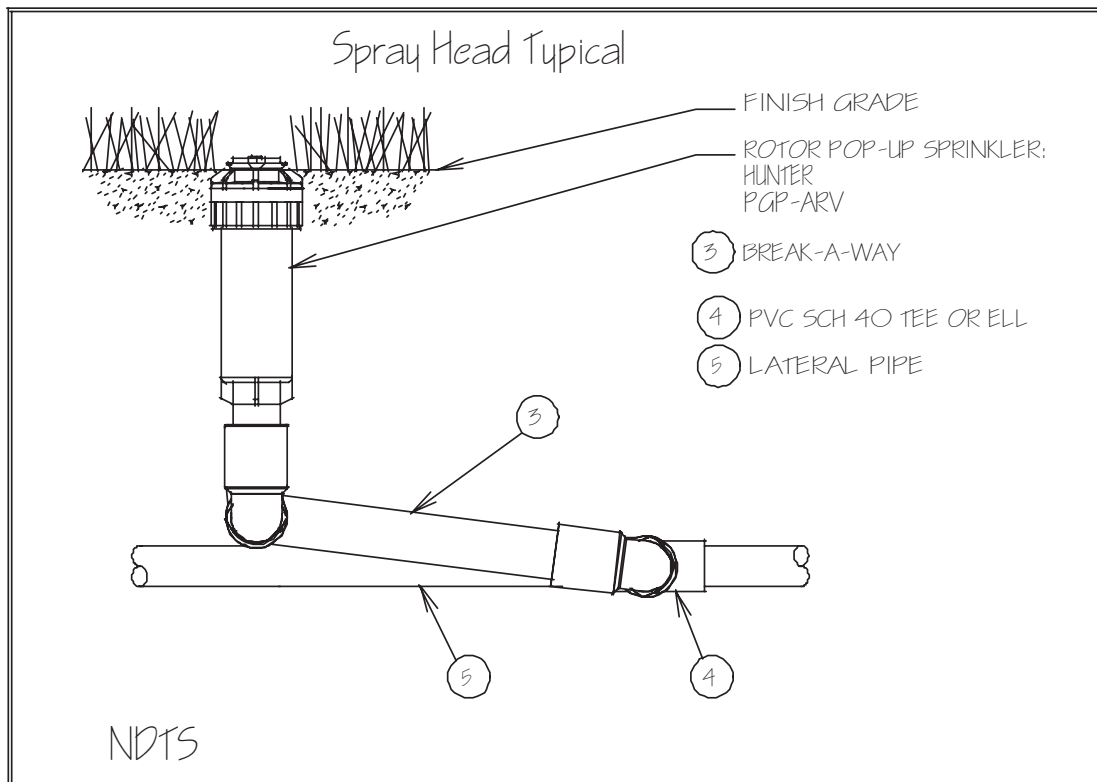

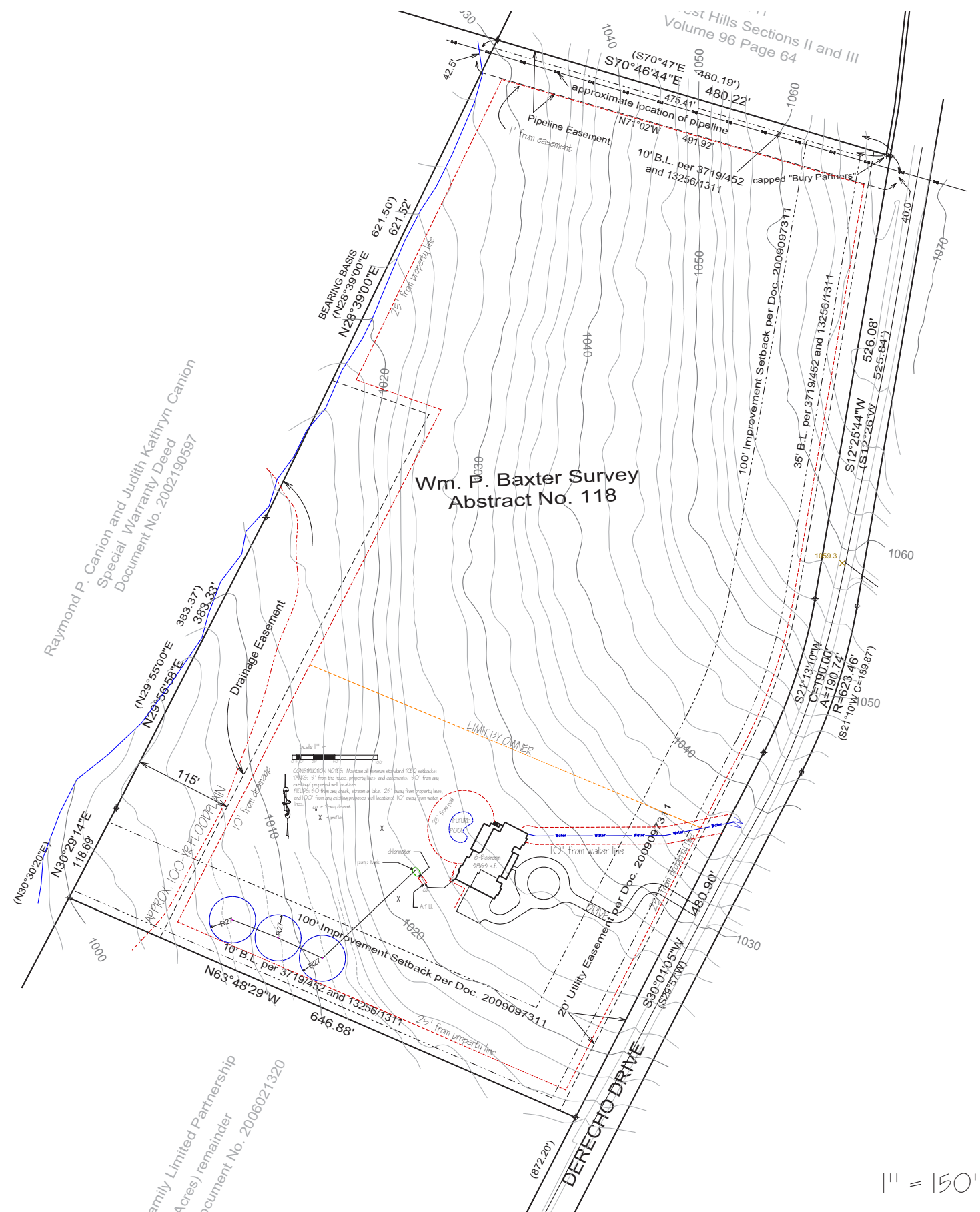

Raymond P. Canyon and Judith Kathryn Canyon
Special Warranty Deed
Document No. 2002190597

Wm. P. Baxter Survey
Abstract No. 118

Family Limited Partnership
Acres) remainder
Document No. 2006021320

1" = 150'

 <p>BRANDON COUCH, R.S. septic design - site evaluation - consulting</p>	<p>2314 ROCK LEDGE DRIVE GEORGETOWN, TX 78626 512 630 8600 512 233 2411 FAX</p>	SITE: 10300 Dereco Drive	PERMIT #:
		16 Acres out of the William P. Baxter Survey, Abs. No. 118	DRAWN DATE:
		OWNER: Nur & Martha Tauba	11/28/09

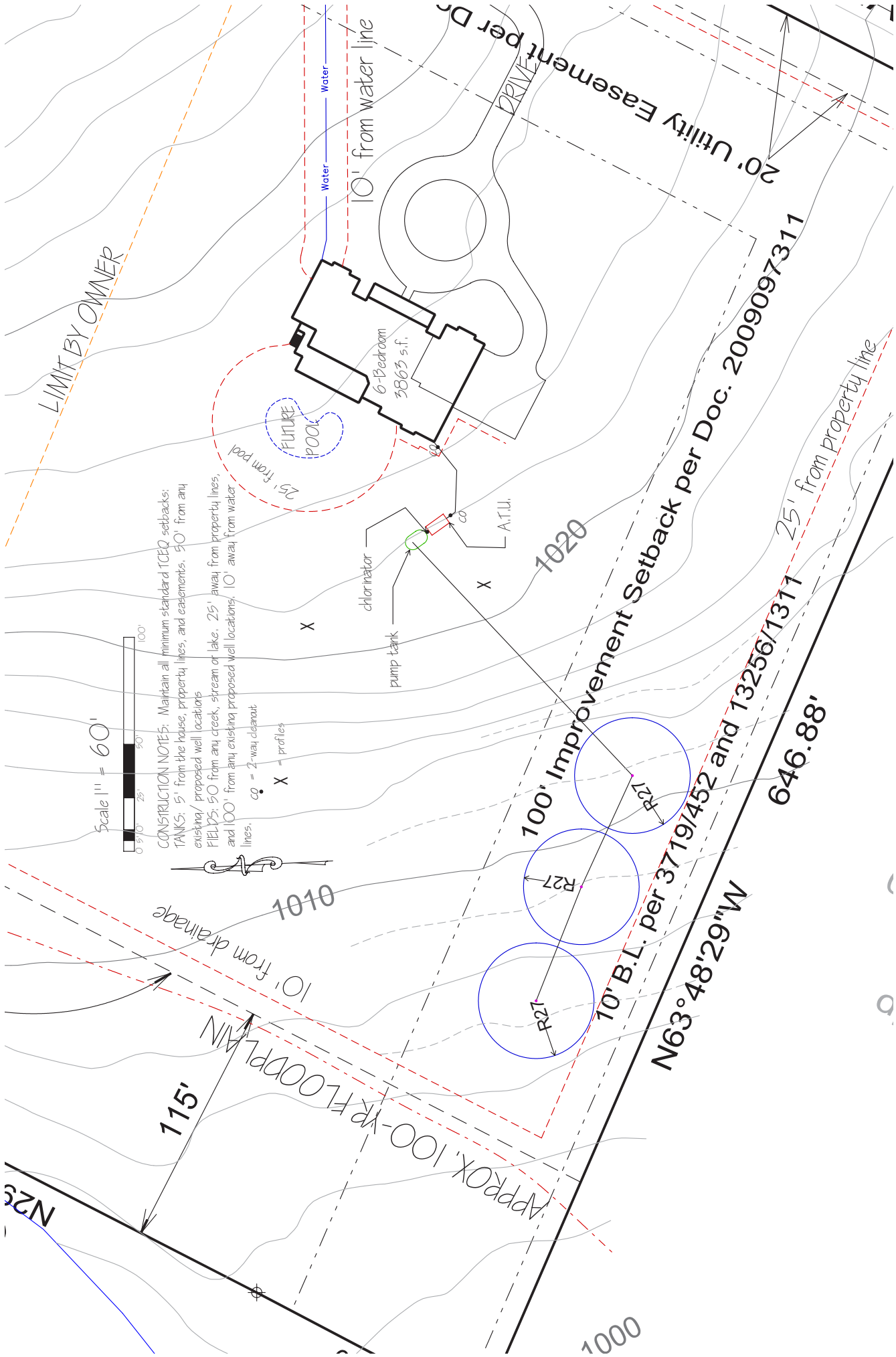

Scale 1" = 60'



CONSTRUCTION NOTES: Maintain all minimum standard TCEQ setbacks:
 TANKS: 5' from the house, property lines, and easements; 50' from any existing/proposed well locations
 FIELDS: 50' from any creek, stream or lake; 25' away from property lines, and 100' from any existing proposed well locations; 10' away from water lines.
 CO = 2-way cleanout
 X = profiles

 BRANDON COUCH, R.S. septic design - site evaluation - consulting	2514 ROCK LEDGE DRIVE GEORGETOWN, TX 78626 512.630.8600 512.233.2411 FAX	SITE: 10300 Derecho Drive 16 Acres out of the William P. Baxter Survey, Abs. No. 118 OWNER: Nur & Martha Tauba	PERMIT #: DRAWN DATE: 11/28/09
	2514 ROCK LEDGE DRIVE GEORGETOWN, TX 78626 512.630.8600 512.233.2411 FAX	SITE: 10300 Derecho Drive 16 Acres out of the William P. Baxter Survey, Abs. No. 118 OWNER: Nur & Martha Tauba	PERMIT #: DRAWN DATE: 11/28/09

Cross-sections

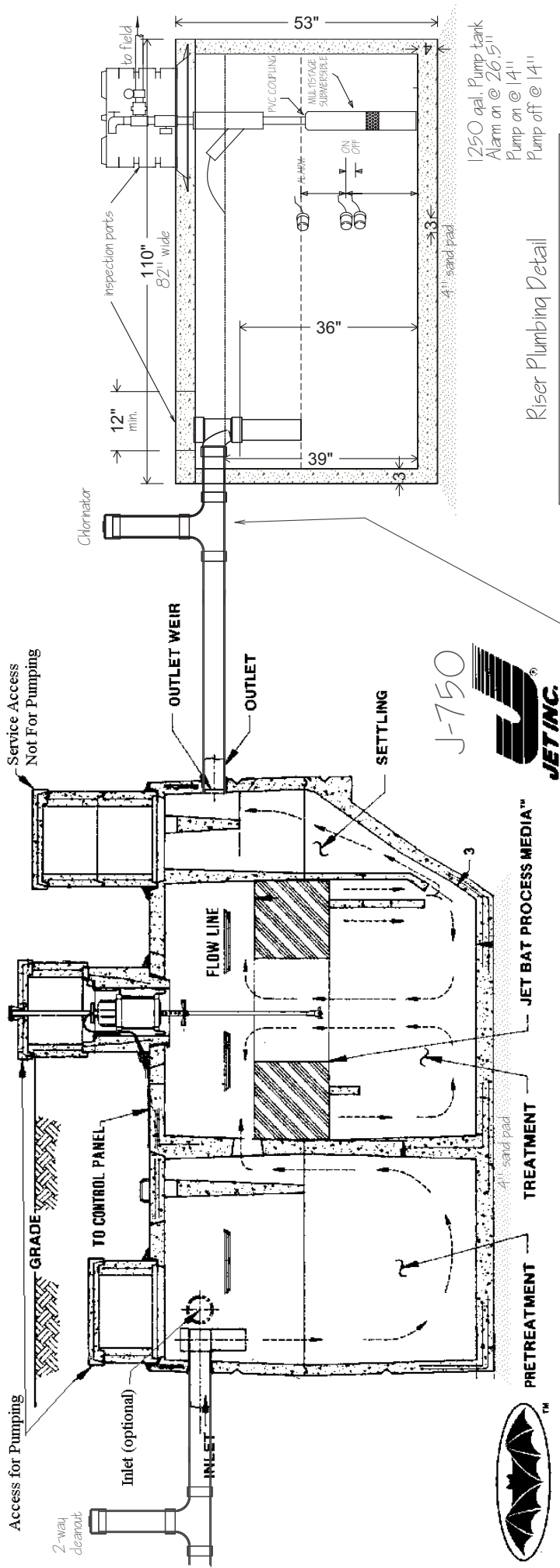

1250 gal. Pump tank
Alarm on @ 26.5"
Pump on @ 14"
Pump off @ 14"

Riser Plumbing Detail

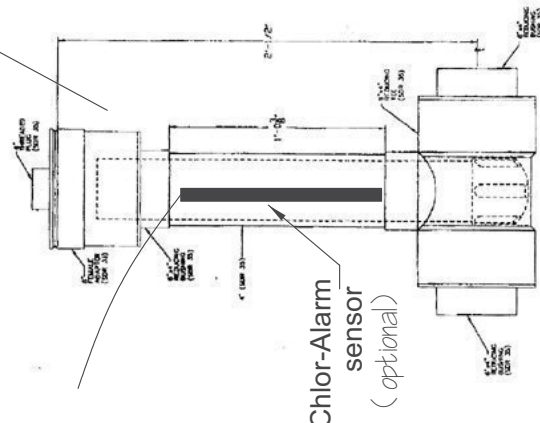
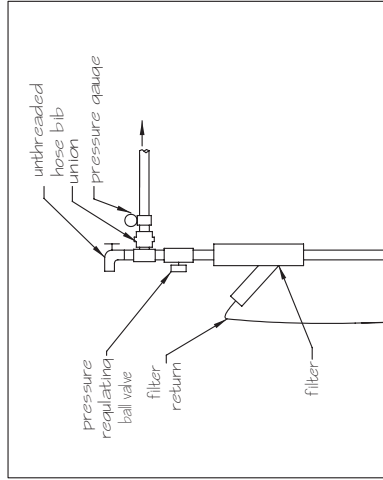

Red Jacket E518/E610 composite curves

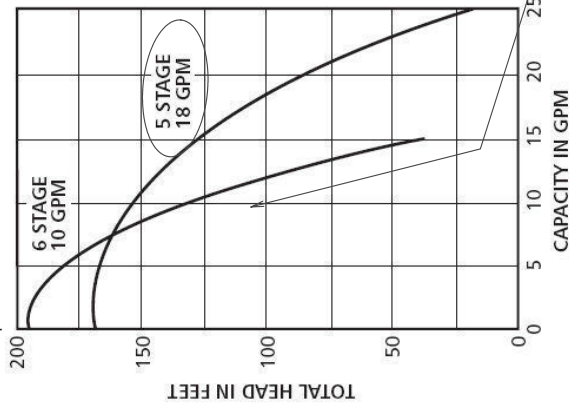

system requirement