

Lecture 12 objectives

- Lab 5 overview
- Verify real-time DAC outputs

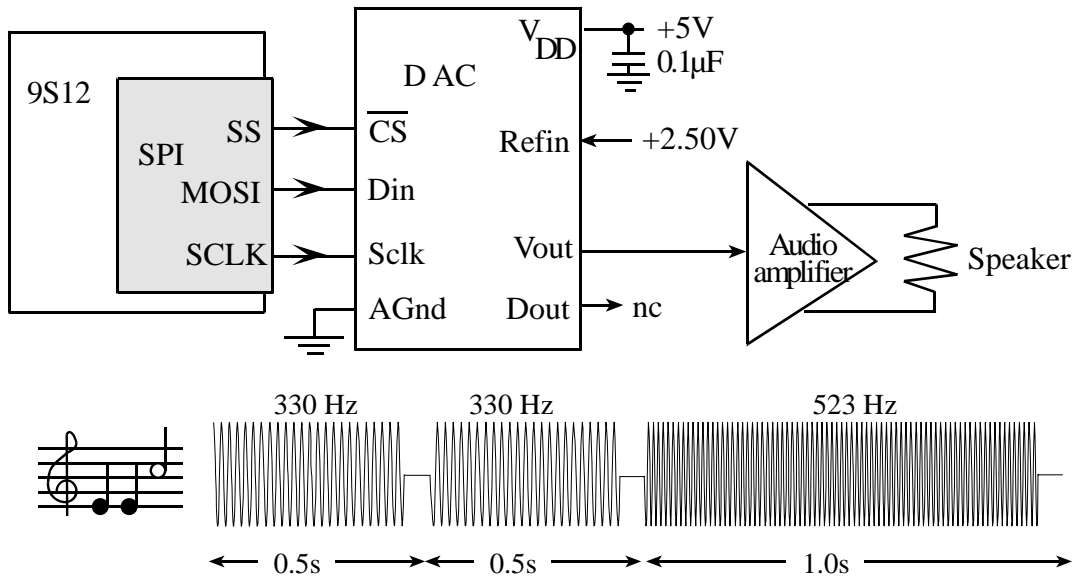

You can control the amplitude, frequency and duration of each note (not drawn to scale).

Design data structures for this information

- Voltage versus time (the sin wave)
- TCNT delays for each note in a scale (pitch)
- Song table (voice, pitch, duration)

How to handle the pauses

- 1) enter the quiet times explicitly into the song table
- 2) create an envelop

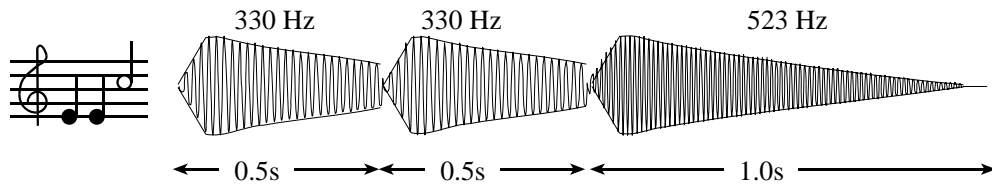

The amplitude of a plucked string drops exponentially in time.

Run Lab 5 solution

Discuss possibilities for the data structures

How to vary pitch?

How to mix multiple channels?

Analog

Digital

View analog signals

Verify real time

- 1) read TCNT value when DAC is actually output
- 2) calculate differences between TCNTs
- 3) either do a histogram (or a simple max difference)