

Jonathan W. Valvano

First: _____ Last: _____

This is the closed book section. You must put your answers in the boxes on this answer page. When you are done, you turn in the closed-book part and can start the open book part.

(10) Question 1. You write code to implement a digital filter. These shared global variables have data **short x,y,z;**

Other software, such as an ISR, will enter data into these variables. Write a C function that calculates

$$z = 0.125*x - 0.375*y + 0.125*z$$

Your function should return the most recent calculation of z. Your function will be called by the main program with interrupts enabled. Eliminate critical sections, minimize dropout, minimize execution speed. Either prove it cannot overflow, or add code to implement ceiling and floor if overflow could occur.

(6) Question 2. Consider the following SysTick ISR. Assume SysTick is initialized to interrupt every 50 μ s. The SysTick is armed and enabled. Assume Port D bit 0 has been configured as an output. Assume also the main program was running when SysTick interrupts are triggered. 0x40007004 is the bit-specific address for the PD0 pin.

```
unsigned long Counts; // records number of SysTick interrupts
#define PD0 (*(volatile unsigned long *)0x40007004)
void SysTick_Handler(void){
    PD0 = 0x01;
    Counts++; // assume this line takes 80ns to execute
    PD0 ^= 0x01;
}
```

Part a) What is in LR during the execution of the ISR?

Part b) What gets pushed on the stack during the invocation of the ISR?

Part c) Sketch the output voltage versus time on PD0. Label the time axis giving as much time information as possible.

(2) **Question 3.** What is the first point of the IEEE Code of Ethics?

(4) **Question 4.** State two differences between ceramic and tantalum capacitors.

(2) **Question 5.** Compare the diameter of an analog communication channel like AM radio to a digital communication channel like ZigBee. Which has a greater diameter, and why?

(2) **Question 6.** A communication channel operates at 1 MHz, and the signal to noise ratio is 30 dB (an SNR of 30db means the signal is 1000 times larger than the noise). What is the channel capacity in bits/sec?

(4) **Question 7.** When interfacing two modules together with a long cable, how do we tell if the connection can be modeled simply by considering voltage, current, resistance and capacitance? Conversely, how do we tell if the connection must be modeled as a transmission line?

(10) Question 8. The LM4F120 processor clock is 80 MHz, the ADC clock is 125 kHz, the UART0 baud rate is 100,000 bits/sec. The SysTick periodic interrupt is triggered at 100 Hz. The LM4F120 ADC has 12 bits. The ADC range is 0 to 3V. During each SysTick ISR, the ADC is sampled once. This sample is converted to voltage, the voltage is converted to an 8-byte fixed-length ASCII string, and this ASCII string is transmitted out UART0 using busy-wait synchronization.

Part a) Estimate the frequency components of the original analog signal that are reliably represented in the serial transmissions.

Part b) Give a rough estimation the total execution time of the SysTick ISR.

(4) Question 9. Give a brief explanation of why we add volatile to definitions of ports. E.g.,
`#define P0 (*((volatile unsigned long *)0x40007004))`

(10) Problem 10. Draw a Moore FSM graph that has two inputs and one output. Let N be the number of times the input A goes from 0 to 1. Let M be the number of times the input B goes from 0 to 1. Consider inputs A and B to be positive logic switches, with the restriction that only one switch will be pressed at a time. Inputs 00 means no switch is pressed; input 01 means B is pressed; input 10 means A is pressed; the input will never be 11. The output will be high if and only if N an even number and M is an even number. Zero is an even number. The controller pattern will be output, input, next. No software is required, just the FSM graph. Use good state names to clarify operation.

(10) Question 11. Develop a Laplace domain solution for the gain of this circuit, $H(s) = Y(s)/X(s)$. Use this solution to sketch the frequency response of the circuit. $1\text{nF} \cdot 10\text{k}\Omega$ is $10\ \mu\text{sec}$.

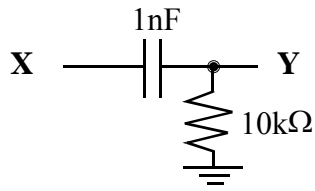

end of closed book section

Jonathan W. Valvano

First: _____ Last: _____

Open book, open notes, calculator (no laptops, phones, devices with screens larger than a TI-89 calculator, devices with wireless communication). You must put your answers on these pages. Please don't turn in any extra sheets.

(10) Question 12. The goal is to interface a motor using a TIP142 NPN Darlington transistor. The motor requires 1A current and has a maximum 8V voltage. A PWM output of the microcontroller ($V_{OH}=3.2V$) will be controlling the interface (no software required). You can choose motor supply voltages of either 5V or 8V. The microcontroller is powered at 3.3V. Make the motor spin as the fast as possible.

Table 4. Electrical characteristics

Symbol	Parameter	Test conditions	Min.	Typ.	Max.	Unit
I_{CBO}	Collector cut-off current ($I_E = 0$)	$V_{CB} = 100\text{ V}$			1	mA
I_{CEO}	Collector cut-off current ($I_B = 0$)	$V_{CE} = 50\text{ V}$			2	mA
I_{EBO}	Emitter cut-off current ($I_C = 0$)	$V_{EB} = 5\text{ V}$			2	mA
$V_{CEO(sus)}^{(1)}$	Collector-emitter sustaining voltage ($I_B = 0$)	$I_C = 30\text{ mA}$	100			V
$V_{CE(sat)}^{(1)}$	Collector-emitter saturation voltage	$I_C = 5\text{ A}$ $I_B = 10\text{ mA}$ $I_C = 10\text{ A}$ $I_B = 40\text{ mA}$			2 3	V V
$V_{BE(on)}^{(1)}$	Base-emitter on voltage	$I_C = 10\text{ A}$ $V_{CE} = 4\text{ V}$			3	V
$h_{FE}^{(1)}$	DC current gain	$I_C = 5\text{ A}$ $V_{CE} = 4\text{ V}$ $I_C = 10\text{ A}$ $V_{CE} = 4\text{ V}$	1000 500			
t_{on}	Resistive load Turn-on time	$I_C = 10\text{ A}$ $R_L = 3\ \Omega$		0.9		μs
t_{off}	Turn-off time	$I_{B1} = -I_{B2} = 40\text{ mA}$		4		μs

1. Pulse test: pulse duration $\leq 300\ \mu\text{s}$, duty cycle $\leq 2\%$.

Show your work, and label all resistors.

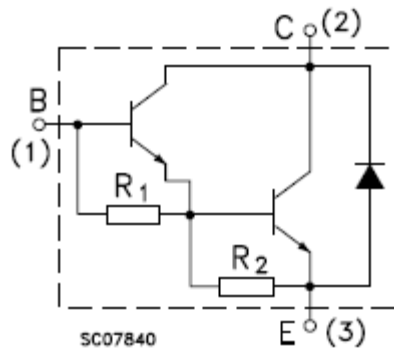

This is a diagram of inside the TIP142

(10) Question 13. Interface this transducer to the ADC. The output voltage of the transducer ranges from 1 to 2V. The transducer is a resistance bridge with a differential output voltage, $V_1 - V_2$. $1 \leq V_1 - V_2 \leq 2$. The signals of interest are 0 to 10 Hz. The software sampling rate will be 20 Hz. There are large unwanted noise signals at 60 120 and 180 Hz. Please include an antialiasing low pass filter. Show all resistors, capacitors, and chip numbers. The available power supply voltage is 3.3V.

(10) Question 15. Add semaphore synchronization so that PD0 is toggled exactly once after each time the function **Trigger** is called. The **Trigger** function is called from the foreground or from another ISR. However the PD0 output must occur in the TIMER0B ISR. Add code to both the ISR and **Trigger** function. If **Trigger** is called five times within the 1ms between TIMER0B interrupts, then the next TIMER0B ISR should toggle five times. The TIMER0B has priority 2, but the ISRs that call **Trigger** may have higher or lower priority than 2. You must also add shared global variable(s). However your solution must not have any critical sections. You may assume TIMER0B is armed and enabled to execute every 1ms. You may assume PD0 is enabled as an output pin. The system should not crash under situations that Timer0B ISR and the **Trigger** function are called at similar times, or if the **Trigger** function is never called.

```
#define PD0 (*(volatile unsigned long *)0x40007004)
```

```
void Timer0B_Handler(void){
    TIMER0_ICR_R = 0x0100; // ack

    PD0 ^= 0x01;
}
```

```
void Trigger(void){
    // add code here

    // other stuff
}
```

(6) Problem 16. What is the transfer function of this circuit?

