

Jonathan W. Valvano

First: _____ Last: _____

This is the closed book section. You must put your answers in the boxes on this answer page. You have 90 min, so please allocate your time accordingly. *Please read the entire exam before starting.*

(4) Problem 1.

Choose A-F

--

(4) Problem 2.

Choose A-H

--

(4) Question 3.

Choose A-D

--

(4) Question 4.

Choose A-D

--

(4) Question 5.

Choose A-F

--

(4) Question 6.

ADC bits

--

(4) Question 7.

Yes or no, if no give example

--

(4) Question 8.

Yes or no, if no give example

--

(4) Question 9.

Choose A-F

--

(2) Question 10.

Choose A-Z,AA-JJ

--

(2) Question 11.

Choose A-Z,AA-JJ

--

(2) Question 12.

Choose A-Z,AA-JJ

--

(2) Question 13.

Choose A-Z,AA-JJ

--

(2) Question 14.

Choose A-Z,AA-JJ

--

(2) Question 15.

Choose A-Z,AA-JJ

--

(2) Question 16.

Choose A-Z,AA-JJ

--

(2) Question 17.

Choose A-Z,AA-JJ

--

(2) Question 18.

Choose A-Z,AA-JJ

--

(2) Question 19.

Choose A-Z,AA-JJ

--

(4) Question 20. There are 10 points to the IEEE Code of Ethics. What is the basic premise of the first point of this code? Give one specific example of how this might apply to embedded systems.

(4) **Question 1.** Consider the following C code

```
short add2(const short input){
    return input+2;
}
```

How would you best describe the **input** parameter?

- | | |
|--|--|
| A) Temporary allocation, private scope | B) Permanent allocation, private scope |
| C) Permanent allocation, public scope | D) Temporary allocation, public scope |
| E) 8-bit precision | F) Nonvolatile |

(4) **Question 2.** You wish to design a system that measures the period of a digital signal. Range of periods is 1 to 2 ms, and the desired resolution is 250ns. Which interrupt mechanism would you use?

- A) Output compare with a fixed period
- B) Output compare with a variable period
- C) Input capture on the rising edge of the digital signal
- D) Input capture on the both the rising and falling edges of the digital signal
- E) PWM interrupt
- F) TOF interrupt when TCNT goes from 0xFFFF to 0
- G) SCI interrupt when RDRF is set
- H) SPI interrupt when SPIF is set

Consider the situation in which the output of one digital circuit is connected to the input of another digital circuit. The difficulty arises because the two digital circuits are built with different logic families (e.g., 74LS, 74HC, 74S, etc.) There are no other connections on this signal, i.e., one output is tied to one input. The output specifications of the first circuit are V_{OH} , V_{OL} , I_{OH} and I_{OL} . The input specifications of the second circuit are V_{IH} , V_{IL} , I_{IH} and I_{IL} . These are the specifications, like you would find in a data sheet, not actual measurements of voltage and current like you would measure in lab with a DVM. In order for this system to operate properly, choose the proper specifications.

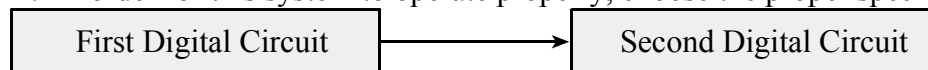

(4) **Question 3.** Consider the voltage when the digital signal is high. Which of these specifications must be satisfied?

- | | |
|--|--|
| A) $V_{OH} \geq V_{IH}$, $ I_{OH} \geq I_{IH} $ | B) $V_{OH} = V_{IH}$, $ I_{OH} = I_{IH} $ |
| C) $V_{OH} \leq V_{IH}$, $ I_{OH} \leq I_{IH} $ | D) None of the above |

(4) **Question 4.** Consider the voltage when the digital signal is low. Which of these specifications must be satisfied?

- | | |
|--|--|
| A) $V_{OL} \geq V_{IL}$, $ I_{OL} \geq I_{IL} $ | B) $V_{OL} = V_{IL}$, $ I_{OL} = I_{IL} $ |
| C) $V_{OL} \leq V_{IL}$, $ I_{OL} \leq I_{IL} $ | D) None of the above |

(4) **Question 5.** An electromagnetic **relay** can be used to switch 120 VAC power to a load. For example, the load might be an AC motor. To activate the relay (apply power to the motor), you must deliver between 4V and 5V to the relay coil. The relay coil impedance is 100Ω in series with 1mH . To deactivate the relay, the relay coil current should be zero. Assume V_{CE} of the transistor is 0.5V . Which interface would you choose for this system. If more than one circuit works choose the best one.

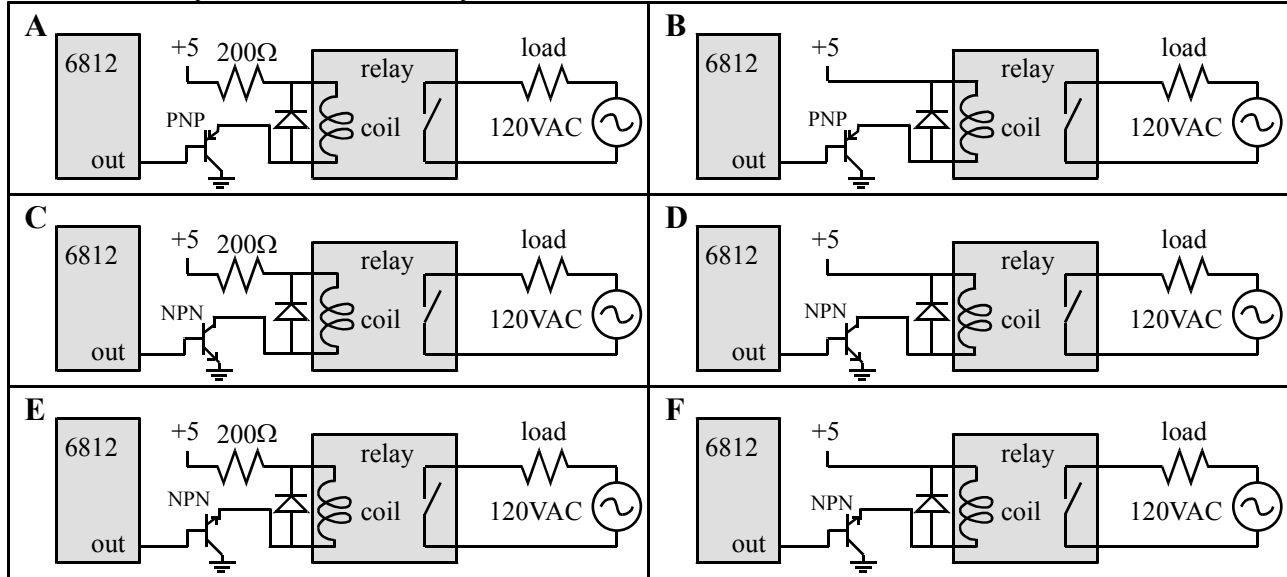

(4) **Question 6.** The desired ADC range is -5V to $+5\text{V}$ with a resolution of 0.001V . How many ADC bits are required?

(4) **Question 7.** Does the associative principle hold for signed integer multiply and divide? In particular do these two C calculations always achieve identical outputs? If not, give an example.

$$\text{Out1} = (\text{A} * \text{B}) / \text{C};$$

$$\text{Out2} = \text{A} * (\text{B} / \text{C});$$

(4) **Question 8.** Does the associative principle hold for signed integer addition and subtraction? In particular do these two C calculations always achieve identical outputs? If not, give an example.

$$\text{Out3} = (\text{A} + \text{B}) - \text{C};$$

$$\text{Out4} = \text{A} + (\text{B} - \text{C});$$

(4) **Question 9.** The following code was used to acknowledge a receive data register full (**RDRF**) interrupt. The flag **RDRF** is bit 5 in the **SCISR1** register. Which explanation best describes this code?

```
SCISR1 |= 0x20;
```

- A) This software only makes the **RDRF** bit high. It is friendly.
- B) This software only makes the **RDRF** bit low. It is friendly.
- C) This software will make all flag bits high in the **SCISR1** register. It is not friendly.
- D) This software will make all flag bits low in the **SCISR1** register. It is not friendly.
- E) This will cause a compile error because the software can not set flag bits in the **SCISR1** register.
- F) This will cause a run-time crash because the software does not clear **RDRF**

For questions 10-19, choose the term that best fits the definition.

<p>(2) Question 10. A multithreaded system where the direct operations of input and output occur in background interrupt service routines, the foreground thread (main program) processes inputs and generates new outputs, and FIFO queues are used to pass data between the foreground and background.</p> <p>(2) Question 11. A communication protocol where just the data (and not the clock) are passed from transmitter to receiver.</p> <p>(2) Question 12. A communication system that can transfer data in two directions, but only one direction at a time.</p> <p>(2) Question 13. You are testing a data acquisition system. Let y_i be 20 measurements performed on the system, and let x_i be the corresponding true values. What is the average difference between the y_i and x_i?</p> $\frac{1}{20} \sum y_i - x_i $ <p>(2) Question 14. You are testing a data acquisition system. Let x_1 and x_2 be two known inputs. If the system can reliably detect when the input changes from x_1 to x_2. What is $x_1 - x_2$?</p>	<p>(2) Question 15. The amount of information transferred per second.</p> <p>(2) Question 16. The amount of time from when the output is idle until the time the computer writes new data to the output device.</p> <p>(2) Question 17. The interrupt mechanism, like output compare, where multiple potential interrupt requests have separate interrupt vectors, separate interrupt flags, separate interrupt arm bits, and separate acknowledge sequences.</p> <p>(2) Question 18. A variable or function that can only be accessed by functions within the same module (e.g., functions within the same file).</p> <p>(2) Question 19. A debugging term that means the act of debugging itself has a small but negligible effect on the system being tested.</p>	<p>A) accuracy B) asynchronous serial C) atomic D) bandwidth E) baud rate F) bit time G) breakpoint H) buffered I/O I) CPU bound J) critical section K) even parity L) frame M) friendly N) full duplex O) half-duplex P) latency Q) minimally intrusive R) nonintrusive S) nonvolatile T) periodic polling U) polled interrupt V) precision W) private X) profile Y) promotion Z) public AA) range BB) real-time CC) reentrant DD) resolution EE) scanpoint FF) simplex GG) stabilize HH) synchronous serial II) vectored interrupt JJ) vulnerable window</p>
---	---	---

(4) Question 20. There are 10 points to the IEEE Code of Ethics. *See answer sheet*

end of closed book section

Jonathan W. Valvano

First: _____ Last: _____

This is the open book section. You must put your answers on pages 5 to 8. You have 90 min, so please allocate your time accordingly.

(5) Question 22. An SPI system is used to interface a 12-bit DAC. The SPI frequency is 1 MHz and it takes two SPI transmissions to send one 12-bit value to the DAC. An analog waveform is created using a 1ms periodic output compare interrupt. During each execution of the output compare ISR exactly one 12-bit value is transmitted to the DAC. What is the actual throughput in bits/sec between the SPI and the DAC?

(10) Question 23. Interface the following 16K ROM to a 6811 running at 2 MHz. Assume the gate delay through each 74HC digital logic gate is [10ns min, 20ns max]. The full address decoder should select addresses \$4000 to \$7FFF. The ROM timing is described in the following figure

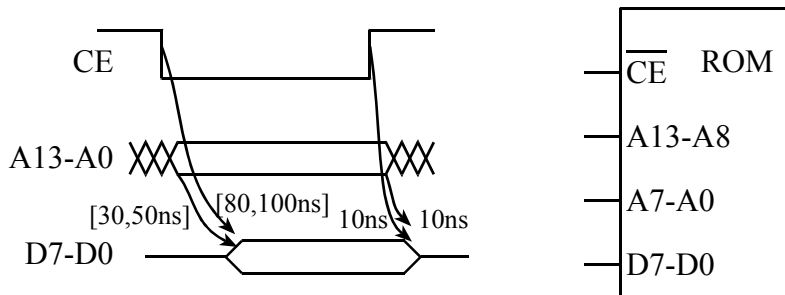

(5) Part a) Design the interface between the ROM to the 6811. You are limited to the following digital devices (you can use more than one copy if you want)

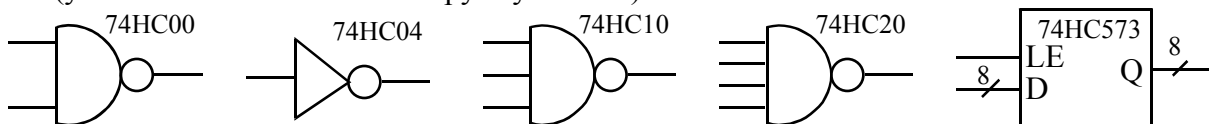

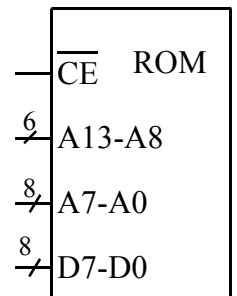
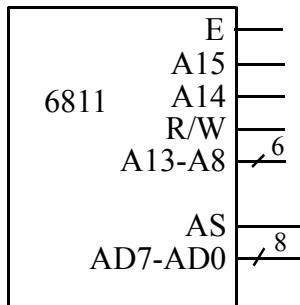

(5) Part b) Read data required is (450,510). Calculate the worst-case **Read Data Available** interval for this interface and show that the timing requirements are satisfied.

(25) Problem 24. Consider a robot with two sensors and two DC motors. The goal is to design the robot so it follows the black line on the track.

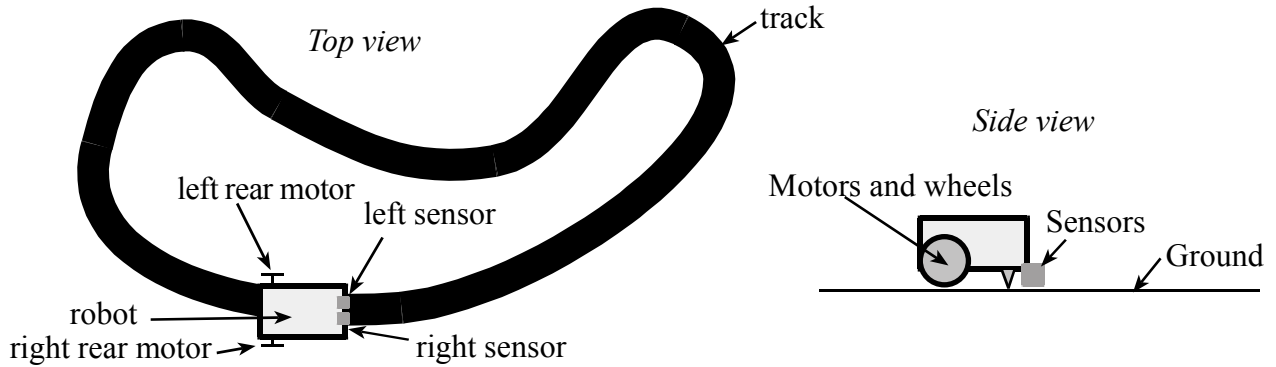

(10) Part a) Each sensor gives a voltage between 1 and 2V if it is positioned over the line on the track, and the sensor gives a voltage between 2 and 3 V if it is not positioned over the line. Design a hardware/software interface between the two sensors and the 6812. Give chip numbers and resistor/capacitor values. Include both the hardware and the software interface. Give the software ritual that initializes the interface. Design a software function that returns 0 if both sensors are not on the line, 1 if just the left sensor is on the line, 2 if just the right sensor is on the line and 3 if both sensors are on the line. *Style matters.*

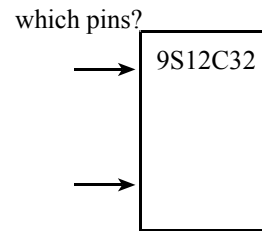
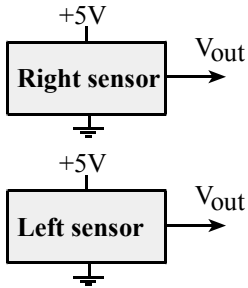

(10) Part b) Each motor requires +12 V at 2 A to turn. Your software needs to be able to activate or deactivate each motor independently. The interface does not need to support turning backward or to support PWM. Design a hardware/software interface between the two motors and the 6812. Give chip numbers and resistor/capacitor/diode values. Include both the hardware and the software interface. Give the software ritual that initializes the interface. Design a software function that accepts a 2-bit call by value parameter: 0 means stop both motors, 1 means activate just the left motor (causing the robot to turn right), 2 means activate just the right motor (causing the robot to turn left), 3 means activate both motors (causing the robot to move forward). *Style matters.*

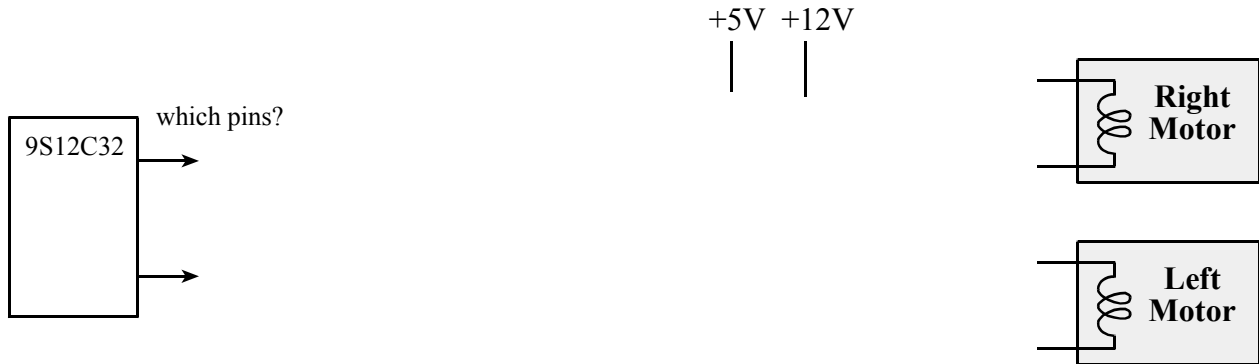

(5) Part c) Design a FSM to implement the line tracking. The 2-bit input comes from the sensors (0,1,2,3) and the 2-bit output goes to the motors(0,1,2,3). The machine will be run in the background using periodic interrupts. No software is required, just show the FSM graph. Give descriptive names for the states.