

TI Robot Systems Learning Kit version 2

Jon Valvano / Daniel Valvano
 May 7, 2018
 RSLK-Maze edition

MSP432 LaunchPad

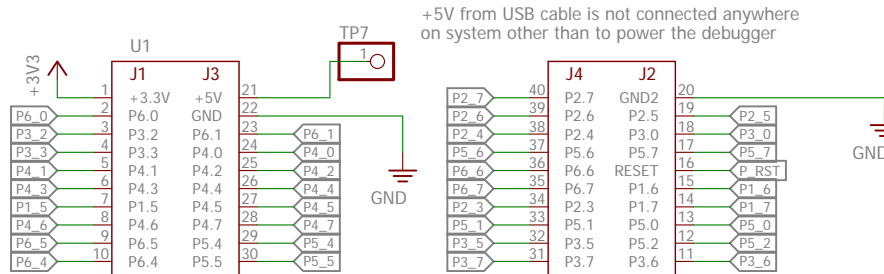

MSP432LAUNCHPAD_J5

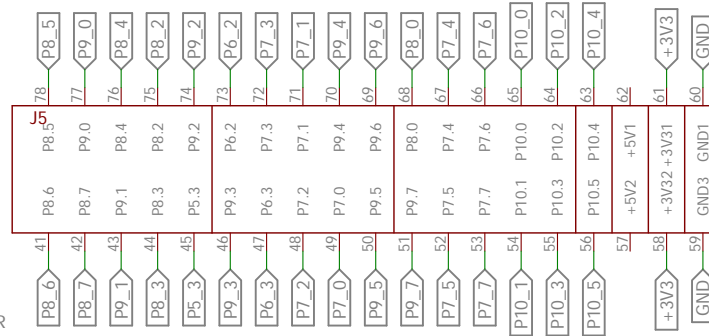

<http://www.ti.com/tool/MSP-EXP432P401R>

Optional I2C Sensor Interface

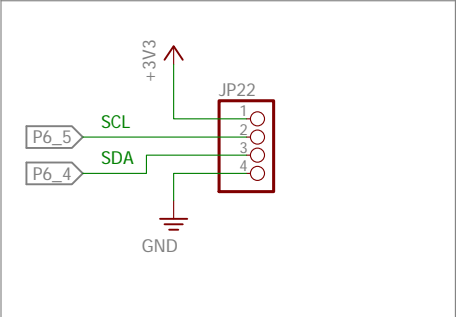

Optional Nokia 5110 LCD

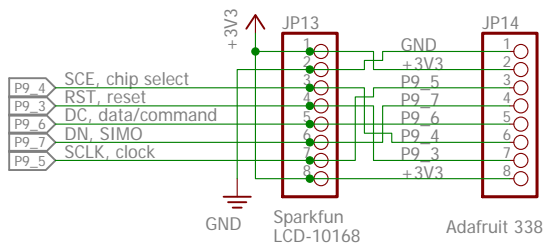

<https://www.sparkfun.com/products/10168>
<https://www.adafruit.com/product/338>

Only solder one JP13 or JP14

Ground for Bump Switches

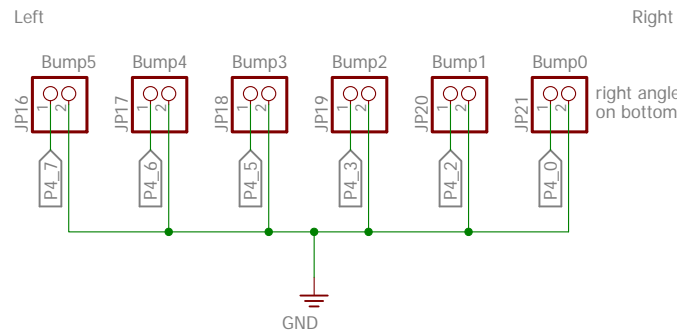

Software uses internal pullup resistors
<https://www.pololu.com/product/1404>

Optional LED Lights

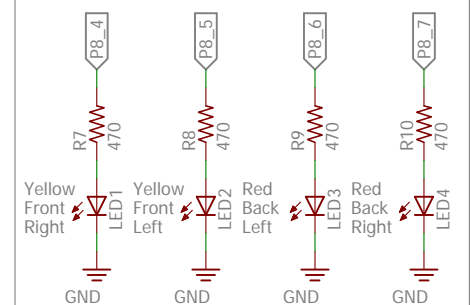

TI Robot Systems Learning Kit version 2

Jon Valvano / Daniel Valvano
 May 7, 2018
 RSLK-Maze edition

