

# EE445M/EE380L.12

## Embedded and Real-Time Systems/ Real-Time Operating Systems

### Lecture 1: Introduction, TM4C123 Microcontroller, ARM Cortex-M

Lecture 1

J. Valvano, A. Gerstlauer  
EE445M/EE380L.12

1

## Embedded Systems

- Reactive, not transformative systems
  - Parallel (interaction with physical world)
  - Real-time (guarantees on reaction time)

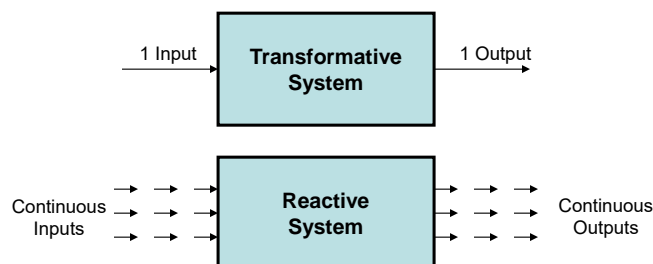

Lecture 1

J. Valvano, A. Gerstlauer  
EE445M/EE380L.12

2

# Parallel Processing (1)

- Distributed systems
  - Multiple computers, separate memory, I/O or network link
    - Simultaneous execution of two or more software tasks
    - E.g. Lab 6 (CAN), Internet

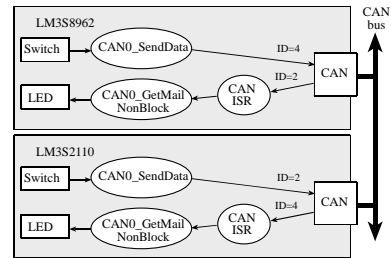

Figure 9.6. Simple CAN network.

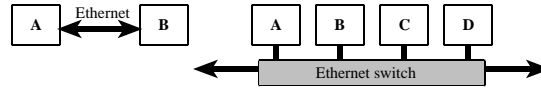

Figure 9.14. Ethernet has a bus-based topology.

Lecture 1

J. Valvano, A. Gerstlauer  
EE445M/EE380L.12

3

# Parallel Processing (2)

- Multi-processing
  - Multiple processors, shared memory
    - Simultaneous execution of two or more software programs (tasks)
    - E.g. multicore CPU, GPU

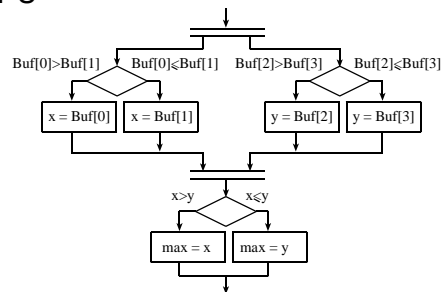

Lecture 1

J. Valvano, A. Gerstlauer  
EE445M/EE380L.12

4

## Parallel Processing (2)

- Multi-threading / Multi-tasking
  - Single processor/core  
(in a distributed and/or multi-processor system)
    - One foreground and multiple background threads (interrupt-driven)
    - Multiple foreground threads using a thread scheduler (*operating system, OS*)

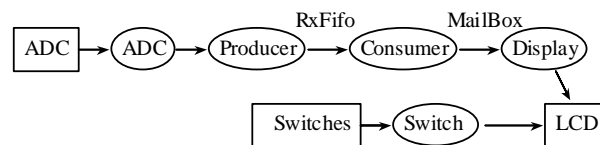

- Multiple independent programs (tasks)

Lecture 1

J. Valvano, A. Gerstlauer  
EE445M/EE380L.12

5

## Class Setup

- Class web page
  - [http://www.ece.utexas.edu/~gerstl/ee445m\\_f20/](http://www.ece.utexas.edu/~gerstl/ee445m_f20/)
- Canvas
  - Announcements, lab report upload, grades
- Communication
  - Piazza for general discussions
  - Gradescope for exam grading and feedback
  - Github for code development & lab submission
  - Mailing list: [f20\\_ee445m@utlists.utexas.edu](mailto:f20_ee445m@utlists.utexas.edu)  
(personal questions to all Professor & TAs)
- Office & lab hours
  - Prof. (Zoom), TAs (lab/Zoom):  
See Canvas and online posted Weekly Schedule

Lecture 1

J. Valvano, A. Gerstlauer  
EE445M/EE380L.12

6

## Course Overview

- Labs (50%)
  - Lab 1: UART, display, ADC (EE445L review)
  - Lab 2: RTOS kernel
  - Lab 3: Scheduling
  - Lab 4: File & disk I/O
  - Lab 5: Memory, process loader
  - Lab 6: Networking, IoT
  - Lab 7: System design project (OS demo)
- Exams (50%)
  - Midterm: Thu, 10/22, during class (tentative)
  - Final: Sat, 12/12, 2-5pm (reg. scheduled)
- Graduate project (20%)
  - Independent RTOS project (proposal by end of September)

Teams of 2

Lecture 1

J. Valvano, A. Gerstlauer  
EE445M/EE380L.12

7

## Announcements

- Labs
  - *No activities this week*
  - TA demos & partner selection next week
  - Lab 1 starts in week 3
- Equipment to get (each student)
  - TM4C123 LaunchPad board (Lab 1)
  - ST7735 LCD display (Lab 1) – requires soldering
  - ESP8266 Wifi module (Lab 6) – may require desoldering
  - Optional: USB logic analyzer (Lab 2)
- We will provide (on loan, return at end of class)
  - Sensor board (can also provide soldered display & ESP)
- Setup laptop to work independently & remotely
  - ARM environment: Keil  $\mu$ Vision 5.x (not 4.7x!) or gcc
  - Starter and driver code: ValvanoWareTM4C123v5
  - Putty or HyperTerminal (serial terminal)

Lecture 1

J. Valvano, A. Gerstlauer  
EE445M/EE380L.12

8

## Lab Access

- Lab space: EER 1.806 (Embedded Systems Lab)
  - Potentially available for use, but not required
    - PCs, soldering stations, scopes, logic analyzers, ...
  - Shared with EE445L & Senior Design
    - Other classes have priority during their lab times
  - COVID-19 capacity: max 3 students + TA
    - Follow posted access hours and protocols
  - TA will be in lab for lab sections next week
    - Available to setup laptop, hand out sensor boards

Lecture 1

J. Valvano, A. Gerstlauer  
EE445M/EE380L.12

9

## Texas Instruments LaunchPad

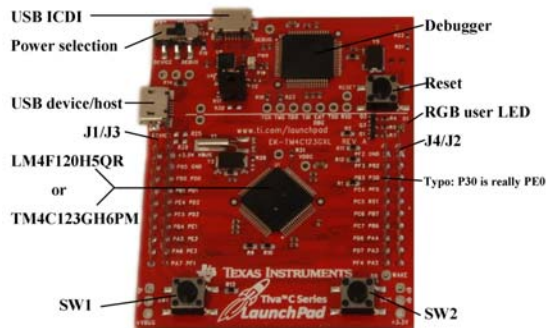

### Debug connections:

- Female-male connectors (attach to top)
  - <https://www.adafruit.com/products/826>
  - DigiKey H1505-ND (Hirose DF11-2428SCA)

### Reference material

- [http://www.ece.utexas.edu/~gerst/ee445m\\_s20/resources.html](http://www.ece.utexas.edu/~gerst/ee445m_s20/resources.html)
- <http://www.ece.utexas.edu/~valvano/arm/> (starter files, example projects)
- TI manuals
  - <http://www.ti.com/lit/ug/spmu296/spmu296.pdf> (LaunchPad User's Guide)
  - <http://www.ti.com/lit/ds/symlink/tm4c123gh6pm.pdf> (TM4C123 data sheet)
  - <http://www.ti.com.cn/cn/lit/ug/spmu159a/spmu159a.pdf> (Cortex-M4 instruction set)
- ARM manuals
  - [https://static.docs.arm.com/ddi0439/b/DDI0439B\\_cortex\\_m4\\_r0p0\\_trm.pdf](https://static.docs.arm.com/ddi0439/b/DDI0439B_cortex_m4_r0p0_trm.pdf) (Cortex-M4 technical reference)

Lecture 1

J. Valvano, A. Gerstlauer  
EE445M/EE380L.12

10

# Sensor Board (Labs 1-7)

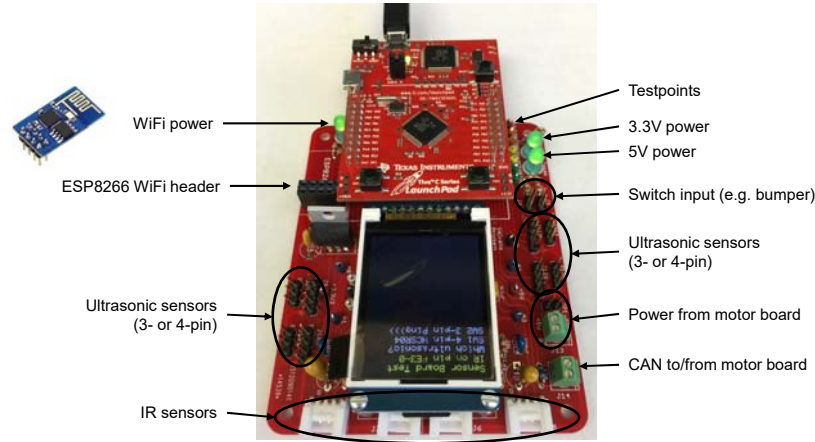

- **Reference material**
  - Schematic: [http://www.ece.utexas.edu/~gerstl/ee445m\\_s16/resources/Robot\\_Sensor\\_v3.pdf](http://www.ece.utexas.edu/~gerstl/ee445m_s16/resources/Robot_Sensor_v3.pdf)
  - PCB layout: [http://www.ece.utexas.edu/~gerstl/ee445m\\_s16/resources/sensor\\_top3.png](http://www.ece.utexas.edu/~gerstl/ee445m_s16/resources/sensor_top3.png)

Lecture 1

J. Valvano, A. Gerstlauer  
EE445M/EE380L.12

11

# Texas Instruments TM4C123

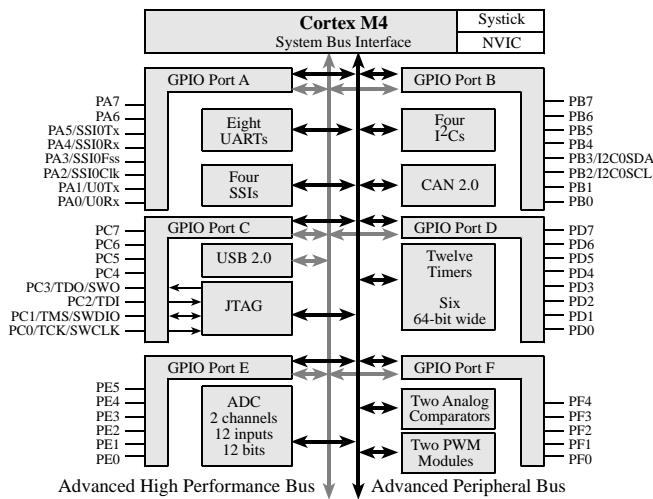

- ARM Cortex-M4**
- + 256K EEPROM**
- + 32K RAM**
- + JTAG**
- + SysTick**
- + ADC**
- + UART**
- + General-Purpose I/O**
  - 4x 8-bit (A, B, C, D)
  - 1x 6-bit (E)
  - 1x 5-bit (F)

Lecture 1

J. Valvano, A. Gerstlauer  
EE445M/EE380L.12

12

## Registers, Memory-map

General purpose registers

R0
R1
R2
R3
R4
R5
R6
R7
R8
R9
R10
R11
R12
R13 (MSP)
R14 (LR)
R15 (PC)

Stack pointer  
Link register  
Program counter

256k Flash ROM
32k RAM
I/O ports
Internal I/O PPB

0x0000.0000  
↓  
0x0003.FFFF  
↓  
0x2000.0000  
↓  
0x2000.7FFF  
↓  
0x4000.0000  
↓  
0x400F.FFFF  
↓  
0xE000.0000  
↓  
0xE004.1FFF

Condition Code Bits	Indicates
N negative	Result is negative
Z zero	Result is zero
V overflow	Signed overflow
C carry	Unsigned overflow

Lecture 1
J. Valvano, A. Gerstlauer  
EE445M/EE380L.12
13

## ARM Thumb Instruction Set

- Arithmetic/Logic
  - AND R1, R2, R3 ; register
  - EOR/ORR R1,R2,#1 ; immediate, 12-bit
  - LSR R1,R1,#4 ; logic shift
  - ADD{S} R1,R2,R3, LSL #2 ; R1=R2+R3\*4 {set condition codes}
  - SUB{S} R1,R3, ASR #2 ; R1=R1+R3/4 {set condition codes}
  - CMP R2,R3 ; compare
- Data movement
  - MOV R0,#100 ; immediate
  - ADR R0,Label ; load address
  - LDR R0,=Label ; uses PC-relative
  - STR{H} R1,[R0] ; indexed {16-bit halfword}
  - LDR{{S}H} R1,[R0,#n] ; offset indexed {{signed} halfword}
- Control
  - B Target ; unconditional
  - BEQ/BNE Target ; (in)quality
  - BLO/BLS/BHI/BHS Target ; unsigned <,<=,>,>=
  - BLT/BLE/BGT/BGE Target ; signed <,<=,>,>=

Lecture 1
J. Valvano, A. Gerstlauer  
EE445M/EE380L.12
14

# Function calls

```
void delay (int cnt){
    while (cnt--);
}

void main(void) {
    delay(10);
}
```

```
delay
SUB    R0,R0,#0x01
BNE    delay
BX     LR

main
MOV    R0,#0x0A
BL     delay
```

**AAPCS: Parameters in R0-R3, return in R0**

**Follow the link register LR**

# Stack

```
void function1 (void)
{
    output(0x01);
}

int main (void) {
    ...
    function1();
    ...
}
```

```
function1
PUSH   {R4-R6,LR}
MOV    R0,#0x01
MOV    R4,#12
BL     output
POP    {R4-R6,PC}

main
...
BL     function1
...
```

**R4-R11 must be saved**

**Draw a stack picture**

The accesses happen in order of decreasing (push)/increasing (pop) register numbers, with the lowest numbered register using the lowest memory address (top of stack) and the highest number register using the highest memory address



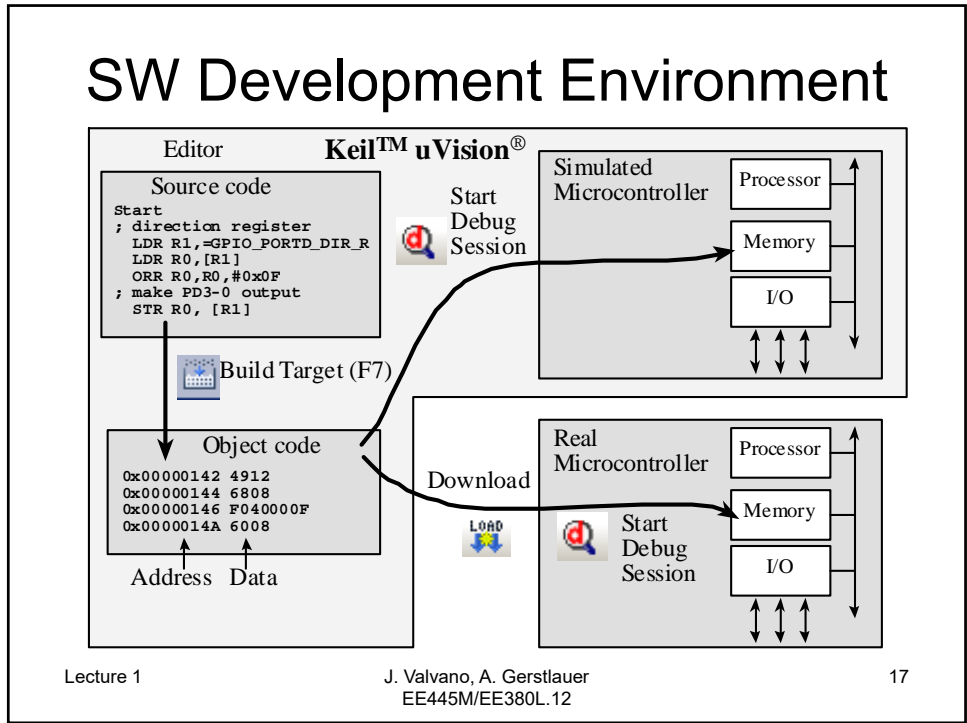

## General-Purpose I/O (GPIO)

Address	7	6	5	4	3	2	1	0	Name
400F.E608	-	-	GPIOF	GPIOE	GPIOD	GPIOC	GPIOB	GPIOA	SYSCTL_RCGCGPIO_R
xxxx.x3FC	DATA	DATA	DATA	DATA	DATA	DATA	DATA	DATA	GPIO_PORTx_DATA_R
xxxx.x400	DIR	DIR	DIR	DIR	DIR	DIR	DIR	DIR	GPIO_PORTx_DIR_R
xxxx.x420	SEL	SEL	SEL	SEL	SEL	SEL	SEL	SEL	GPIO_PORTx_AFSEL_R
xxxx.x510	PUE	PUE	PUE	PUE	PUE	PUE	PUE	PUE	GPIO_PORTx_PUR_R
xxxx.x51C	DEN	DEN	DEN	DEN	DEN	DEN	DEN	DEN	GPIO_PORTx_DEN_R

- **Initialization**
  1. Turn on clock in `SYSCTL_RCGCGPIO_R`
  2. Wait two bus cycles (two NOP instructions)
  3. Set `DIR` to 1 for output or 0 for input
  4. Clear `AFSEL` & `AMSEL` bits to 0 to select regular I/O
  5. Set `DEN` bits to 1 to enable data pins
- **Input/output from pin**
  6. Read/write `GPIO_PORTx_DATA_R`

Lecture 1 J. Valvano, A. Gerstlauer 18  
EE445M/EE380L.12

## Bit-Specific Port I/O

- Bit-specific addressing is used to access port data register
  - Define address offset as  $4 \cdot 2^b$ , where  $b$  is the selected bit position
  - 256 possible bit combinations (0-8)
  - Add offsets for each bit selected to base address for the port
  - Other bits masked during access
  - `DATA_R @ base+$3FC` equals all bits

If we wish to access bit	Constant
7	0x0200
6	0x0100
5	0x0080
4	0x0040
3	0x0020
2	0x0010
1	0x0008
0	0x0004

Example: PF4 and PF0

Port F = 0x4005.D000

$0x4005.D000 + 0x0004 + 0x0040$   
 = 0x4005.D044

*Provides friendly and atomic access to port pins*

Lecture 1

J. Valvano, A. Gerstlauer  
 EE445M/EE380L.12

19

## LaunchPad Switches and LEDs

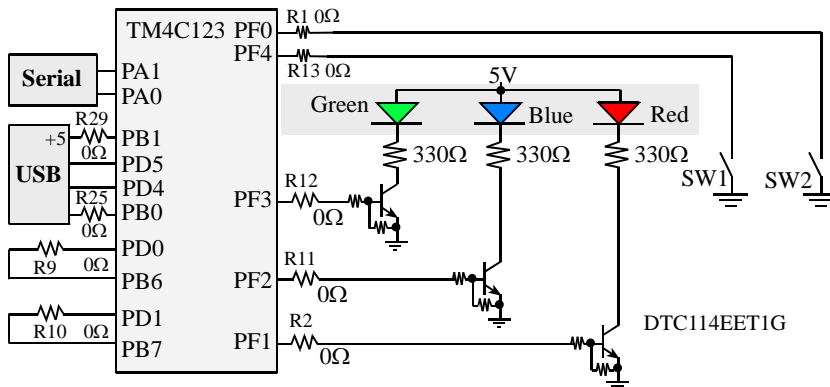

- The switches on the LaunchPad
  - Negative logic, require internal pull-up (set bits in PUR)
- The PF3-1 LEDs are positive logic

Lecture 1

J. Valvano, A. Gerstlauer  
 EE445M/EE380L.12

20

# Interrupts \*\*

*Before interrupt*

*After interrupt*

*Context Switch*

Finish instruction

- a) Push registers
- b) PC = <vector address>
- c) IPSR = <intr. number>
- d) LR = 0xFFFFFxx

\*\* More details in Lecture 3

Lecture 1
J. Valvano, A. Gerstlauer  
EE445M/EE380L.12
21

# Interrupt Vectors

Vector address	Number	IRQ	ISR name in Startups	NVIC	Priority bits
0x00000014	14	-2	PendSV_Handler	NVIC_SYS_PRI3_R	23-21
0x0000001C	15	-1	SysTick_Handler	NVIC_SYS_PRI3_R	31-29
0x00000040	16	0	GPIOPortA_Handler	NVIC_PRI0_R	7-5
0x00000044	17	1	GPIOPortB_Handler	NVIC_PRI0_R	15-13
0x00000048	18	2	GPIOPortC_Handler	NVIC_PRI0_R	23-21
0x0000004C	19	3	GPIOPortD_Handler	NVIC_PRI0_R	31-29
0x00000050	20	4	GPIOPortE_Handler	NVIC_PRI1_R	7-5
0x00000054	21	5	UART0_Handler	NVIC_PRI1_R	15-13
0x00000058	22	6	UART1_Handler	NVIC_PRI1_R	23-21
0x0000005C	23	7	SSI0_Handler	NVIC_PRI1_R	31-29
0x00000060	24	8	I2C0_Handler	NVIC_PRI2_R	7-5
0x00000064	25	9	PWMFault_Handler	NVIC_PRI2_R	15-13
0x00000068	26	10	PWM0_Handler	NVIC_PRI2_R	23-21
0x0000006C	27	11	PWM1_Handler	NVIC_PRI2_R	31-29
0x00000070	28	12	PWM2_Handler	NVIC_PRI3_R	7-5
0x00000074	29	13	Quadrature0_Handler	NVIC_PRI3_R	15-13
0x00000078	30	14	ADC0_Handler	NVIC_PRI3_R	23-21
0x0000007C	31	15	ADC1_Handler	NVIC_PRI3_R	31-29
0x00000080	32	16	ADC2_Handler	NVIC_PRI4_R	7-5
0x00000084	33	17	ADC3_Handler	NVIC_PRI4_R	15-13
0x00000088	34	18	WDT_Handler	NVIC_PRI4_R	23-21
0x0000008C	35	19	Timer0A_Handler	NVIC_PRI4_R	31-29
0x00000090	36	20	Timer0B_Handler	NVIC_PRI5_R	7-5
0x00000094	37	21	Timer1A_Handler	NVIC_PRI5_R	15-13
0x00000098	38	22	Timer1B_Handler	NVIC_PRI5_R	23-21
0x0000009C	39	23	Timer2A_Handler	NVIC_PRI5_R	31-29
0x000000A0	40	24	Timer2B_Handler	NVIC_PRI6_R	7-5
0x000000A4	41	25	Comp0_Handler	NVIC_PRI6_R	15-13
0x000000A8	42	26	Comp1_Handler	NVIC_PRI6_R	23-21
0x000000AC	43	27	Comp2_Handler	NVIC_PRI6_R	31-29
0x000000B0	44	28	SysCtl_Handler	NVIC_PRI7_R	7-5
0x000000B4	45	29	FlashCtl_Handler	NVIC_PRI7_R	15-13
0x000000B8	46	30	GPIOPortF_Handler	NVIC_PRI7_R	23-21
0x000000BC	47	31	GPIOPortG_Handler	NVIC_PRI7_R	31-29
0x000000C0	48	32	GPIOPortH_Handler	NVIC_PRI8_R	7-5
0x000000C4	49	33	UART2_Handler	NVIC_PRI8_R	15-13
0x000000C8	50	34	SSI1_Handler	NVIC_PRI8_R	23-21
0x000000CC	51	35	Timer3A_Handler	NVIC_PRI8_R	31-29
0x000000D0	52	36	Timer3B_Handler	NVIC_PRI9_R	7-5
0x000000D4	53	37	I2C1_Handler	NVIC_PRI9_R	15-13
0x000000D8	54	38	Quadrature1_Handler	NVIC_PRI9_R	23-21
0x000000DC	55	39	CAN0_Handler	NVIC_PRI9_R	31-29
0x000000E0	56	40	CAN1_Handler	NVIC_PRI10_R	7-5
0x000000E4	57	41	CAN2_Handler	NVIC_PRI10_R	15-13
0x000000E8	58	42	Ethernet_Handler	NVIC_PRI10_R	23-21
0x000000EC	59	43	Hibernate_Handler	NVIC_PRI10_R	31-29
0x000000F0	60	44	USB0_Handler	NVIC_PRI11_R	7-5
0x000000F4	61	45	PWM3_Handler	NVIC_PRI11_R	15-13
0x000000F8	62	46	uDMA_Handler	NVIC_PRI11_R	23-21
0x000000FC	63	47	uDMA_Error	NVIC_PRI11_R	31-29

Lecture 1
J. Valvano, A. Gerstlauer  
EE445M/EE380L.12
22

## Nested Vectored Interrupt Controller (NVIC)

- Priorities (global level in **BASEPRI**)

Address	31 – 29	23 – 21	15 – 13	7 – 5	Name
0xE000E400	GPIO Port D	GPIO Port C	GPIO Port B	GPIO Port A	NVIC_PRI0_R
0xE000E404	SSI0, Rx Tx	UART1, Rx Tx	UART0, Rx Tx	GPIO Port E	NVIC_PRI1_R
0xE000E408	PWM Gen 1	PWM Gen 0	PWM Fault	I2C0	NVIC_PRI2_R
0xE000E40C	ADC Seq 1	ADC Seq 0	Quad Encoder	PWM Gen 2	NVIC_PRI3_R
0xE000E410	Timer 0A	Watchdog	ADC Seq 3	ADC Seq 2	NVIC_PRI4_R
0xE000E414	Timer 2A	Timer 1B	Timer 1A	Timer 0B	NVIC_PRI5_R
0xE000E418	Comp 2	Comp 1	Comp 0	Timer 2B	NVIC_PRI6_R
0xE000E41C	GPIO Port G	GPIO Port F	Flash Control	System Control	NVIC_PRI7_R
0xE000E420	Timer 3A	SSI1, Rx Tx	UART2, Rx Tx	GPIO Port H	NVIC_PRI8_R
0xE000E424	CAN0	Quad Encoder 1	I2C1	Timer 3B	NVIC_PRI9_R
0xE000E428	Hibernate	Ethernet	CAN2	CAN1	NVIC_PRI10_R
0xE000E42C	uDMA Error	uDMA Soft Tfr	PWM Gen 3	USB0	NVIC_PRI11_R
0xE000ED20	SysTick	PendSV	--	Debug	NVIC_SYS_PRI3_R

- Interrupt enable
  - **NVIC\_EN0\_R** and **NVIC\_EN1\_R**

Lecture 1

J. Valvano, A. Gerstlauer  
EE445M/EE380L.12

23

## SysTick Timer

Address	31-24	23-17	16	15-3	2	1	0	Name
\$E000E010	0	0	COUNT	0	CLK_SRC	INTEN	ENABLE	NVIC_ST_CTRL_R
\$E000E014	0	24-bit RELOAD value						NVIC_ST_RELOAD_R
\$E000E018	0	24-bit CURRENT value of SysTick counter						NVIC_ST_CURRENT_R

- Timer/Counter
  - 24-bit counter decrements at bus clock frequency
    - With 80 MHz bus clock, decrements every 12.5 ns
  - Counting is from  $n \rightarrow 0$ 
    - Setting  $n$  appropriately will make the counter a modulo  $n+1$  counter:
      - $\text{next\_value} = (\text{current\_value} - 1) \bmod (n+1)$
      - Sequence:  $n, n-1, n-2, n-3 \dots 2, 1, 0, n, n-1 \dots$
- Initialization
  1. Clear **ENABLE** to stop counter
  2. Specify the **RELOAD** value
  3. Clear the counter via **NVIC\_ST\_CURRENT\_R**
  4. Set **CLK\_SRC=1** and specify interrupt action via **INTEN**

Lecture 1

J. Valvano, A. Gerstlauer  
EE445M/EE380L.12

24

## System Tick (Initialization)

```
void SysTick_Init(unsigned long period) { volatile unsigned long delay;
SYSCTL_RCGC2_R |= SYSCTL_RCGC2_GPIOD; // activate port D
Counts = 0; delay = SYSCTL_RCGC2_R; // init, allow time to finish
GPIO_PORTD_DIR_R |= 0x01; // make PD0 output
GPIO_PORTD_DEN_R |= 0x01; // enable digital I/O on PD0

NVIC_ST_CTRL_R = 0; // disable SysTick during setup
NVIC_ST_RELOAD_R = period - 1; // reload value
NVIC_ST_CURRENT_R = 0; // any write to current clears it
// SysTick=priority 2
NVIC_SYS_PRI3_R = (NVIC_SYS_PRI3_R & 0x00FFFFFF) | 0x40000000;
NVIC_ST_CTRL_R = NVIC_ST_CTRL_ENABLE + NVIC_ST_CTRL_CLK_SRC
+ NVIC_ST_CTRL_INTEN;
EnableInterrupts();
}
```

PeriodicSysTickInts\_4C123

Lecture 1

J. Valvano, A. Gerstlauer  
EE445M/EE380L.12

25

## System Tick

```
#define GPIO_PD0 (*(volatile unsigned long *) 0x40007004)

void SysTick_Handler(void) {
GPIO_PD0 = GPIO_PD0 ^ 0x01;
Counts = Counts + 1;
}

void main(void){
...
SysTick_Init(50000); // 1msec, assuming 50 MHz bus clock
...
}
```

PeriodicSysTickInts\_4C123

Reset debugger:  
- stop in ISR and  
- single step through ISR  
- look at assembly code

Lecture 1

J. Valvano, A. Gerstlauer  
EE445M/EE380L.12

26

## Other Peripherals (Lab 1)

- Serial I/O (UART)
  - `UARTInts_4C123`
- Analog-to-digital conversion (ADC)
  - `ADCSWTrigger_4C123`
- LCD display (ST7735) via GPIO
  - `ST7735_4C123`
- General-purpose timers
  - `PeriodicTimer2AInts_4C123` (Timer2A)

Lecture 1

J. Valvano, A. Gerstlauer  
EE445M/EE380L.12

27

## Terminal I/O

- UART0 connected to USB serial port
- How to do terminal input/output?
  1. Write your own, like `UARTInts`
  2. Use `sprintf()` to create strings then output string
  3. Retarget and link to standard library
    - Output using stdlib function `printf()`
      - `fputc()` & `_ttywrch()` mapped to `Your_UART_OutChar()`
    - Input using stdlib function `getchar()`
      - `fgetc()` mapped to `Your_UART_InChar()`

Lecture 1

J. Valvano, A. Gerstlauer  
EE445M/EE380L.12

28

## Stdio Retargeting

```
int fputc(int ch, FILE *f){
    UART_OutChar(ch);
    return (1);
}

int fgetc (FILE *f){
    return (UART_InChar());
}

int ferror(FILE *f){
    /* Your implementation of ferror */
    return EOF;
}
```

retarget.c in C:\Keil\_v5\ARM\Startup

Lecture 1

J. Valvano, A. Gerstlauer  
EE445M/EE380L.12

29

## Starter Code and Driver Lib

- How much code to reuse?
  - Starter files (Valvano) & `driverlib` (TI) will have fewer bugs than any you or I write
  - You will have to certify all code working in parallel environment (critical sections)
  - Most students will want to fit code into 32k
  - All students must understand everything

Lecture 1

J. Valvano, A. Gerstlauer  
EE445M/EE380L.12

30

## Lab 1 Starter Project

- **RTOS\_Lab1\_Interpreter** project
  - Application/user code (**Lab1.c**)
- **RTOS\_Labs\_common** code
  - Command line (**Interpreter.c**) to be developed
  - OS kernel (**os.c**, **osasm.s**) developed in labs
  - Drivers to be developed (**ST7735.c**, **ADC.c**)
  - Custom copies of standard drivers (**UART0Int.c**)
- Standard drivers (from **inc** directory)
  - Timers, ADC, ...

Lecture 1

J. Valvano, A. Gerstlauer  
EE445M/EE380L.12

31

## Summary

- Setup Laptop & Keil
- Learn ARM assembly language
- Get your board & display
- Get familiar with TM4C123 microcontroller
- Get started on Lab 1!
  - If you can finish Lab 1 by yourself, you will be fine in this class...

Lecture 1

J. Valvano, A. Gerstlauer  
EE445M/EE380L.12

32