

Overview

MOSFETS are voltage-controlled switches. Unlike triacs, MOSFETS have the capability of being turned on *and turned off*. They also switch much faster than triacs. As illustrated in Figure 1, the MOSFET acts as a unidirectional switch between the drain and source terminals, and has an internal antiparallel diode. An applied gate-to-source voltage of approximately 4 or 5 V is sufficient to turn on the MOSFET (i.e., resistance between drain and source becomes a few tenths of an ohm). Faster turn on is achieved when 12-18V is applied. Then, when the gate-to-source voltage is set to zero, the MOSFET turns off (i.e., drain-to-source resistance becomes very large).

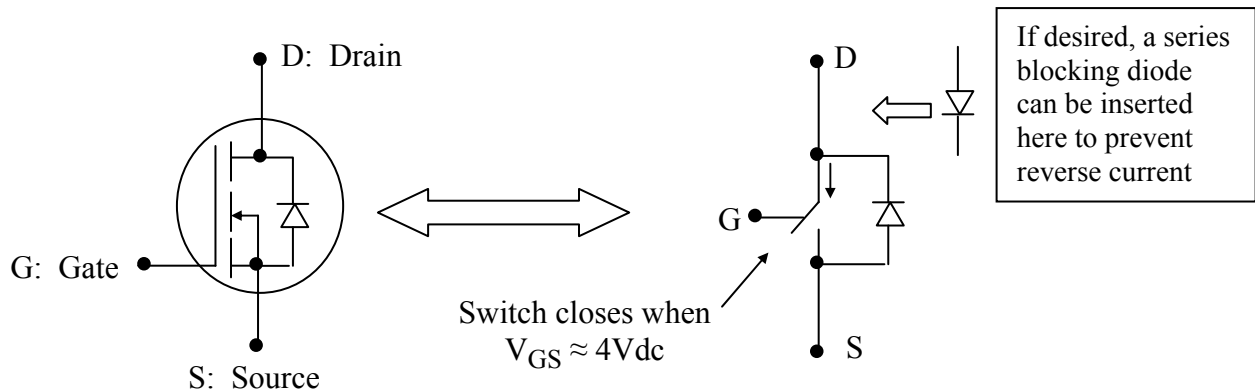

Figure 1. N Channel MOSFET Equivalent Circuit

A Warning about Static Electricity

Until they are properly mounted with a gate pull-down resistor, a MOSFET is very sensitive to burn out if its gate terminal is touched. **Do not take the MOSFET out of its anti-static bag until you are ready to mount it on the PC board, and then always use a grounded static wrist strap and/or static mat when handling the MOSFET.** Avoid touching the gate terminal.

When using a wrist strap, attach the wrist alligator clip end of the strap to the metal switch plate cover on the right-hand side of the lab benches. As an extra precaution, frequently touch the metal power switch plate cover with your hand.

Testing a MOSFET

If you suspect that your MOSFET has failed, perform the following test:

- Remove any connections to either the drain or source terminals, except keep the 100kΩ pull-down resistor connected from gate to source.
- With no V_{GS} applied, measure R_{DS} with an ohmmeter. Expect $R_{DS} \rightarrow \infty$ (i.e., MΩs).
- Now, while measuring R_{DS} , temporarily connect a 6-to-18V V_{GS} . Expect to see $R_{DS} \rightarrow 0$ (i.e., few tenths Ω). Remove the temporary connection, and expect to return to $R_{DS} \rightarrow \infty$.

This test can be also be performed with the MOSFET tester in the power lab. The tester circuit is mounted on a piece of wood and uses a 1" diameter red LED for testing under load.

EE462L, Power Electronics, MOSFET Firing Circuit

Version Feb. 6, 2013

The voltage divider for duty cycle control consists of two resistors and either an A10k Ω (for Buck) or B10k Ω (for Boost or Buck/Boost) potentiometer. The “A” in “A10k Ω ” stands for audio taper, meaning that the resistance of the potentiometer varies logarithmically. B10k Ω has linear taper. In Figure 2, as the duty cycle “D” potentiometer is turned clockwise, voltage to the “Duty” pin #1 increases, the duty cycle of the pulses to the *inverting* driver chip decreases, so that D of the inverting driver output increases. The combination of resistors and potentiometer prevent D from exceeding 0.95 for buck, and 0.80 and 0.70 for boost and buck/boost, so that the MOSFET is never fully “on” (an important feature for boost or buck/boost converters). The modeled variations are given in Figures 3a, 3b, and 3c.

The sawtooth wave frequency of the PWM modulator is proportional to $1/RC$, where R is the series combination of an A10k Ω potentiometer and 470 Ω resistor, and C is 6.8nF. Decreasing R increases frequency. In Figure 2, turning the A10k Ω “Freq” potentiometer clockwise decreases R, and thus increases frequency. As the potentiometer is turned clockwise, the amount of resistance change per angular degree of movement decreases. The nonlinear resistance variation of an audio pot yields a more linear variation of frequency than can be achieved with a linear potentiometer (see Figure 4).

D vs. Potentiometer Angle

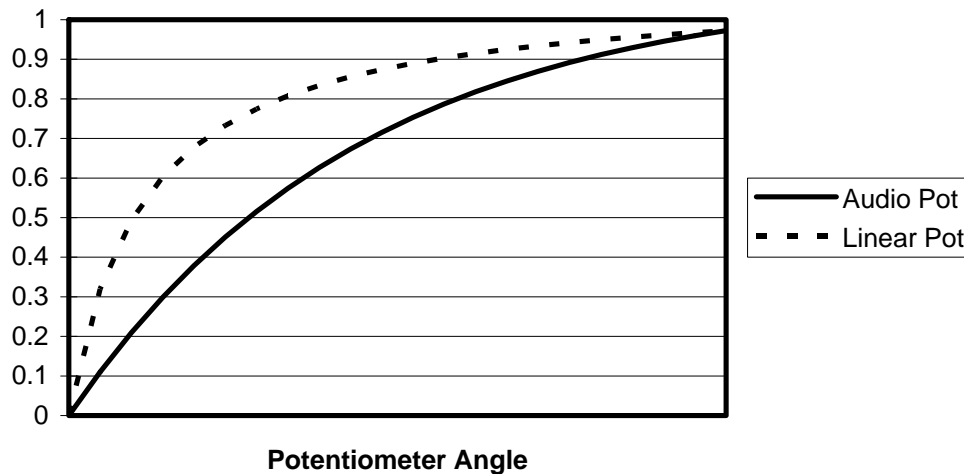

Figure 3a. Duty Cycle D (and V_{out}/V_{in}) Variation in Buck Converter vs. Potentiometer Angle (EE362L_MOSFET_Firing_Circuit_Duty_Variation.xls)

Boost Vout/Vin vs. Potentiometer Angle

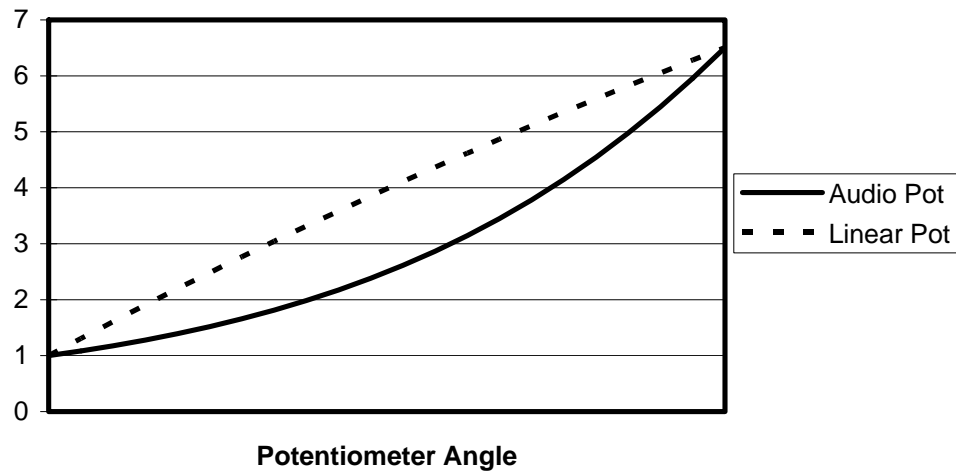

Figure 3b. Vout/Vin Variation in Boost Converter vs. Potentiometer Angle
(EE362L_MOSFET_Firing_Circuit_Duty_Variation.xls)

Buck/Boost Vout/Vin vs. Potentiometer Angle

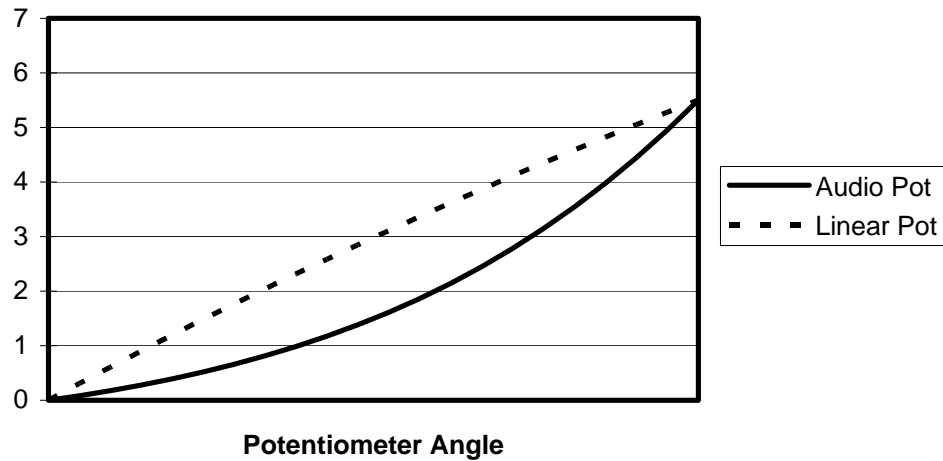

Figure 3c. Vout/Vin Variation in Buck/Boost Converter vs. Potentiometer Angle
(EE362L_MOSFET_Firing_Circuit_Duty_Variation.xls)

Frequency Variation vs. Potentiometer Angle

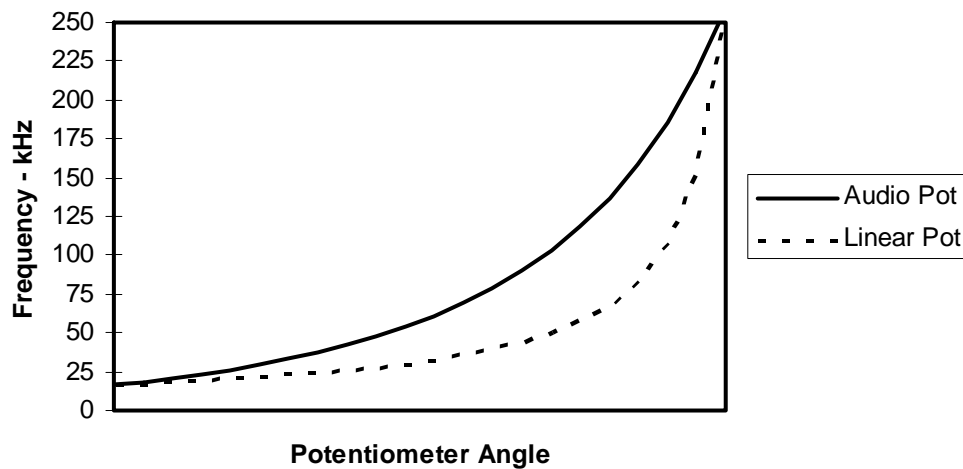

Figure 4. Frequency F Variation vs. Potentiometer Angle
(EE362L_MOSFET_Firing_Circuit_Freq_Variation.xls)

Circuit Construction:

- Ohm-check the PC board **before** mounting any components. This means ohm-checking each pad for connections to the ground plane, power plane, or neither plane.
- Traces are rated per 0.025" of width. Thus, a 0.10" trace is rated 4A. The widest single trace available is 0.15", corresponding to 6A. Traces can be paralleled.
- It is best to keep at least 0.2" between components
- Personal preference – no traces on the bottom side
- Use nylon screws and standoffs to support the PC board
- Wide traces are stronger, especially at corners, and easy to touch with a scope probe
- Personal preference – use ½ W resistors because it is easy to attach a scope probe to their leads
- Resistor bodies should be slightly elevated so they do not touch the PC board
- Use sockets for the chips so they can be easily replaced and removed for reuse.

EE462L, Power Electronics, MOSFET Firing Circuit

Version Feb. 6, 2013

Next: Temporarily connect a $12V_{dc}$ regulated wall wart to the DC jack and use a voltmeter to determine which pin is +12V, and which pin is ground. Now, disconnect the wall wart. Then,

1. Mount and solder the $100k\Omega$ MOSFET gate-to-source pull-down resistor.
2. Mount and solder the three-terminal Phoenix Contact “green plug,” so that the tightening screws face the outer edge of the PC board.
3. Mount the 1.5” corner bracket with two #6 nylon knurled-head thumb screws, using a $\frac{1}{4}$ ” #6 nylon spacer between each screw and the surface of the PC board.
4. **The most important step. Use a static wristband. Avoid touching the gate terminal.** Take the MOSFET out of the pink antistatic bag, place a very thin layer of heat sink compound on the back of the MOSFET, and run a #4 nylon knurled-head thumb screw through the MOSFET and heat sink holes. Insert the MOSFET pins into the green plug and push the #4 thumb screw through the 1.5” bracket. Place a $\frac{1}{8}$ ” inch, #6 nylon spacer on the back of the corner bracket, and tighten the assembly with a #4, $\frac{3}{4}$ inch threaded spacer. Then, tighten the green plug’s three screws to make a solid electrical connection with the MOSFET’s pins.

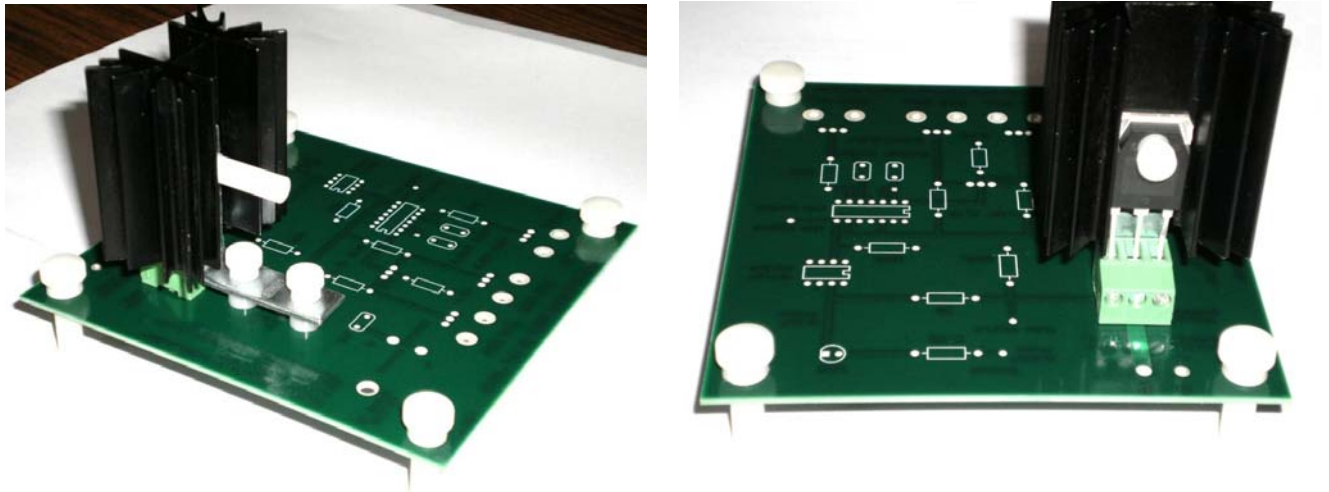

Figure 5. Example of MOSFET Assembly. Actual PCB configuration may differ from those shown in these pictures.

EE462L, Power Electronics, MOSFET Firing Circuit

Version Feb. 6, 2013

5. Mount the DC jack. Before soldering any leads to the jack, plug in a 12Vdc wall to determine the + and – terminals. Then, disconnect the 12Vdc wall wart.
6. Mount all remaining components.
7. Plug in the wall wart. Make sure that each chip is receiving the proper +12V supply voltage. Do this using multimeter measurements directly at the appropriate pins on the chips. Check the voltage at pin 12 of the PWM modulator chip with respect to ground. Expect 5V.
8. Connect an oscilloscope probe to the logic output of the PWM chip (i.e., pin 8). Adjust D. The waveform should vary sharply between zero and (about) 4.5V, with inverted duty cycle. Move the probe to the output of the driver to view V_{GS} . This V_{GS} is “open circuit” because the driver is not yet connected to the MOSFET. The waveform should be switching sharply between 0 and 12V. Use the oscilloscope to measure duty cycle D and frequency F. Vary the D and F potentiometers to observe the ranges of D and F. Expect $0.05 < D < 0.95$ (for buck), and $15\text{kHz} < F < 200\text{kHz}$. D and F should increase as their respective potentiometers are rotated clockwise. Save a representative screen snapshot of V_{GS} for your report, with $D \approx 0.8$, and $F \approx 150\text{kHz}$.
9. With no DBR connected and a frequency of 200 kHz, capture a screenshot similar to that on top of slide 27 of the class notes and use this screen capture to estimate the MOSFET gate-to-source capacitance.
10. Lower D to the minimum, and unplug the wall wart.

EE462L, Power Electronics, MOSFET Firing Circuit
Version Feb. 6, 2013

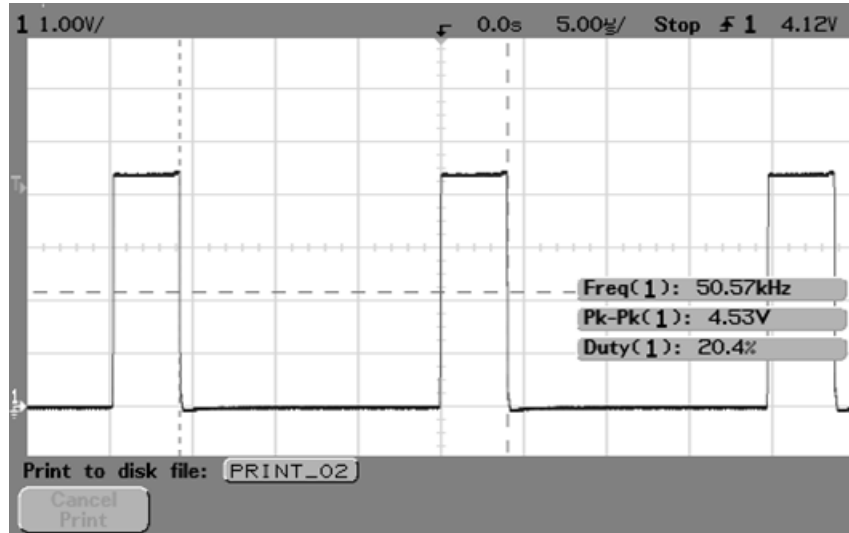

PWM Logic Output (i.e., Pin 8)

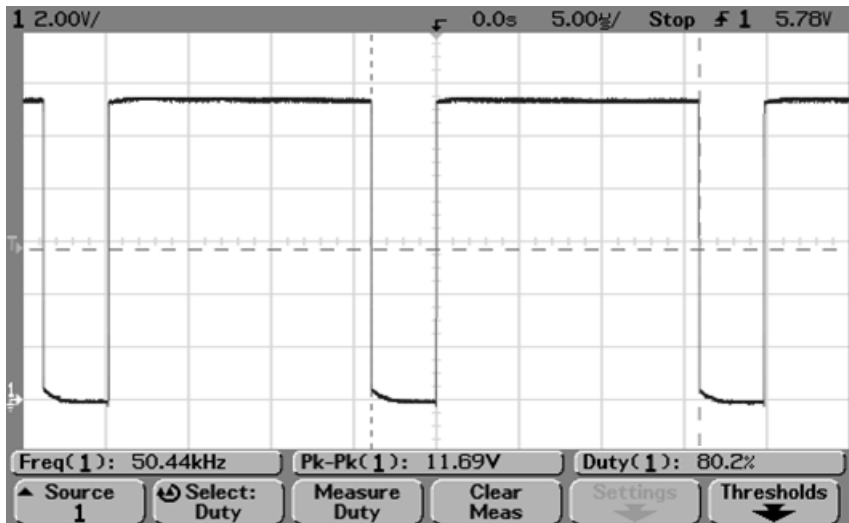

Open-Circuited Driver Chip Output V_{GS}

EE462L, Power Electronics, MOSFET Firing Circuit

Version Feb. 6, 2013

11. Screw a $0.022\mu\text{F}$ ceramic capacitor to the MOSFET drain and source green plug terminals.
12. Use #14 or #16 wire jumpers to connect a DBR and a load, forming a series circuit as shown in Figure 6. Keep the wires as short as possible.

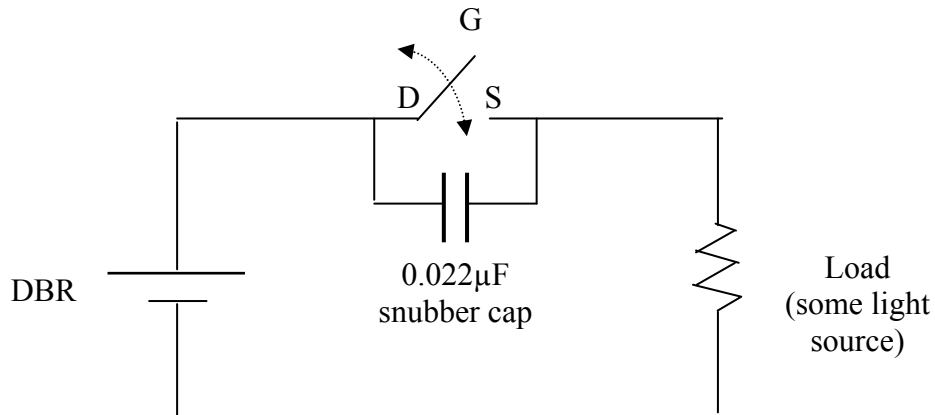
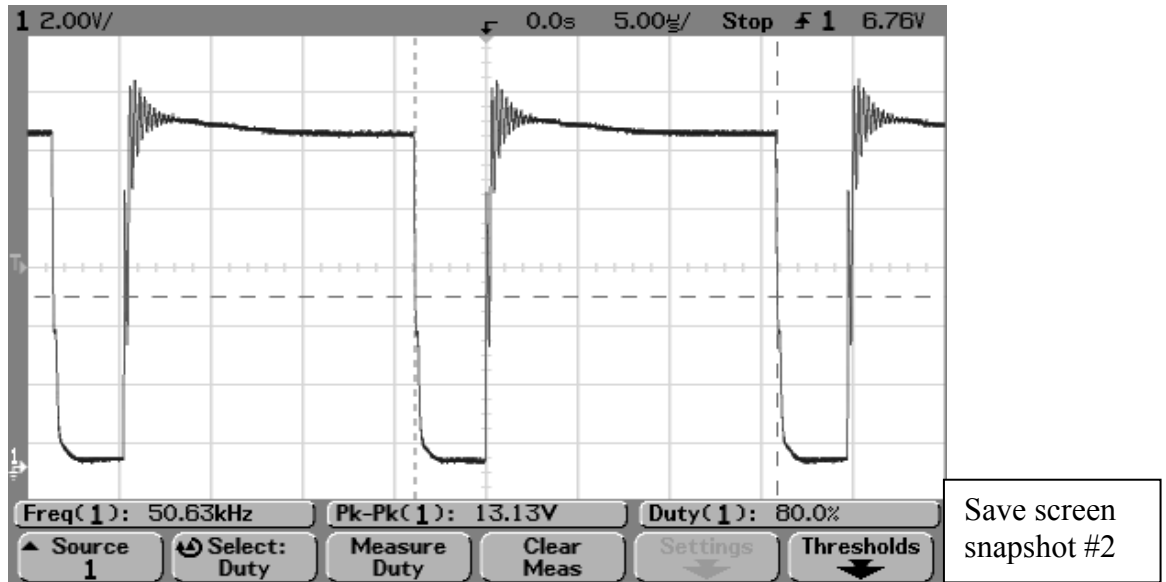

Figure 6. MOSFET Light Dimmer Circuit

(Note – the ground of the wall wart and protoboard is a different potential than the ground of the DBR. Do not connect these grounds together.)

13. Make sure that the DBR switch is “off.” Plug the DBR into a 25V transformer, and the 25V transformer into a variac. Set the variac voltage to zero.
14. Plug in the wall wart, turn “on” the DBR switch, and slowly raise the variac output to 120V.
15. Now, use the MOSFET as a DC light dimmer. Observe V_{GS} at the MOSFET on an oscilloscope while varying D and F over their ranges. Save the V_{GS} waveform with $D \approx 0.8$, and $F \approx 150\text{kHz}$.

EE462L, Power Electronics, MOSFET Firing Circuit
Version Feb. 6, 2013



V_{GS} with a Load

16. Observe V_{DS} at the MOSFET on an oscilloscope while varying D and F over their ranges. Save the V_{DS} waveform with $F \approx 150\text{kHz}$, $D \approx 0.8$. Measure the peak value of V_{DS} , and use cursors to estimate the turn-off and turn-on ringing frequencies.

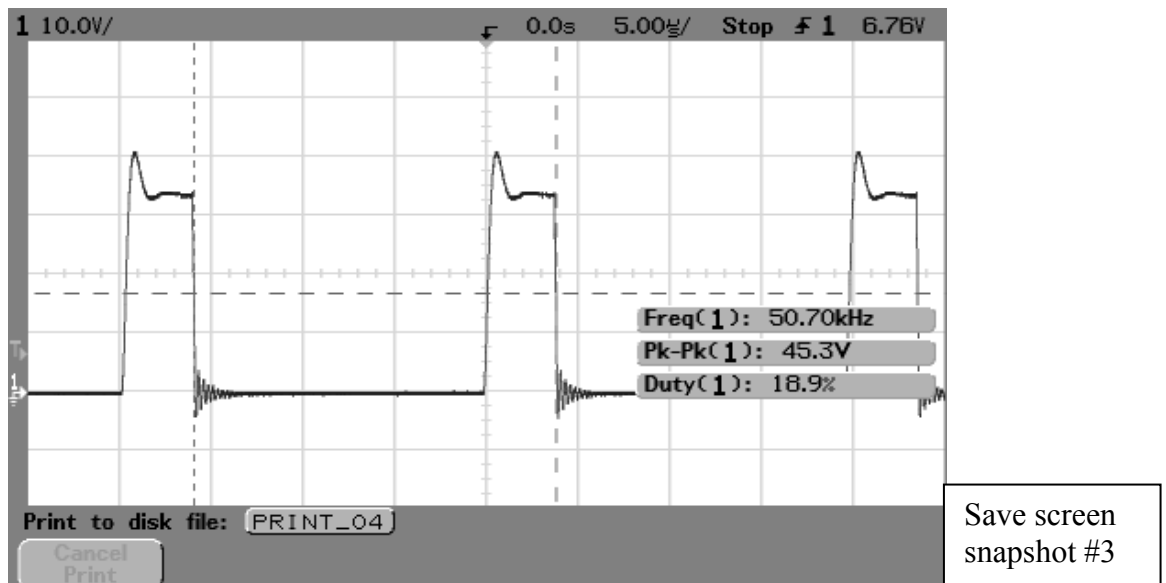

V_{DS} with a Load, with Snubber Capacitor, showing a Peak Value of
About 45V
[note – the duty cycle of V_{DS} is $(1 - D)$]

EE462L, Power Electronics, MOSFET Firing Circuit
Version Feb. 6, 2013

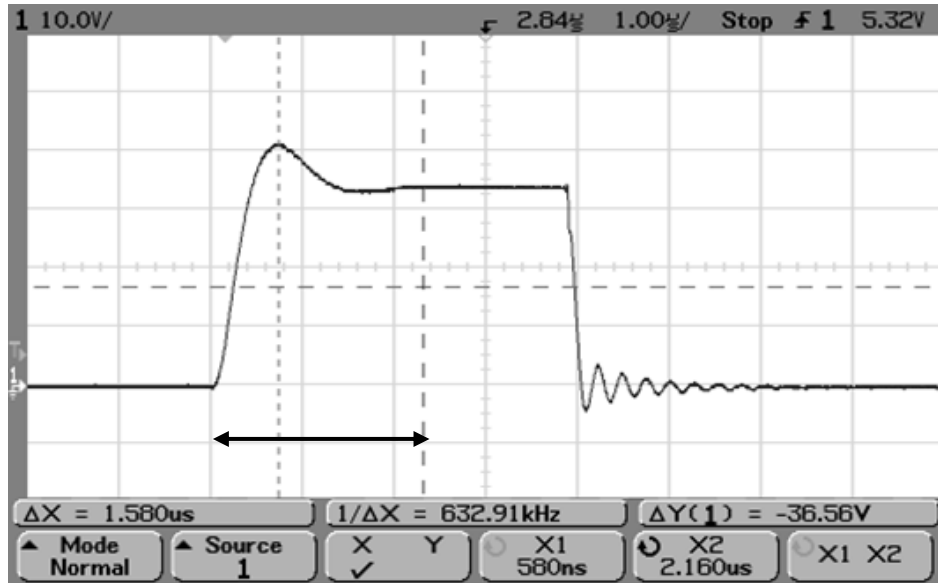

V_{DS} **Turn-Off** Transient, with Snubber Capacitor, is approximately 633kHz

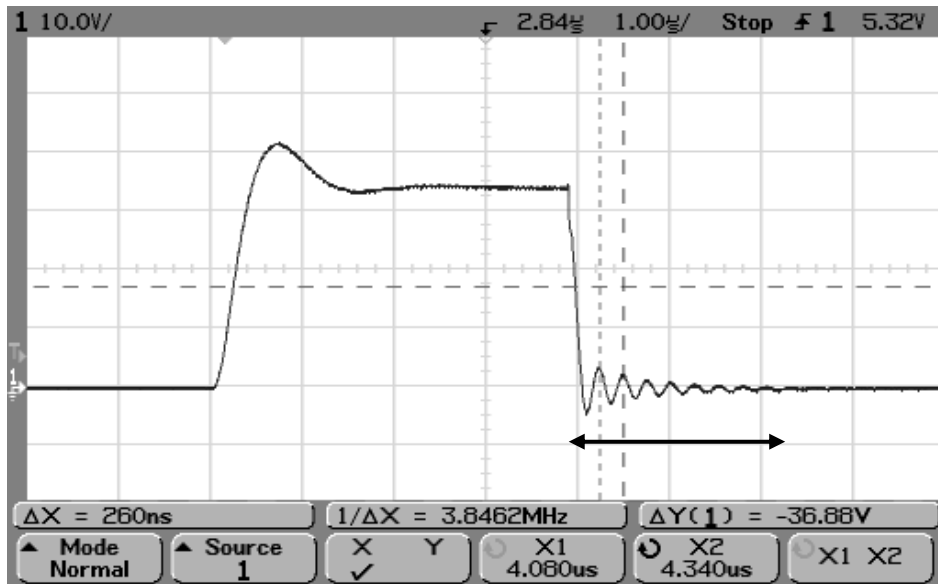

V_{DS} **Turn-On** Transient, with Snubber Capacitor, is approximately 3.9MHz

EE462L, Power Electronics, MOSFET Firing Circuit

Version Feb. 6, 2013

17. **Turn off the DBR**, and then remove the snubber capacitor. Power up, and repeat the peak voltage and turn-off frequency measurements. Observe the impact that the snubber capacitor has on the peak value of V_{DS} . **Note – do not remove or connect the snubber with DBR power applied because the resulting sparks can burn out the MOSFET.**
18. Do the hard switching load test indicated in slide 28 of the class notes.

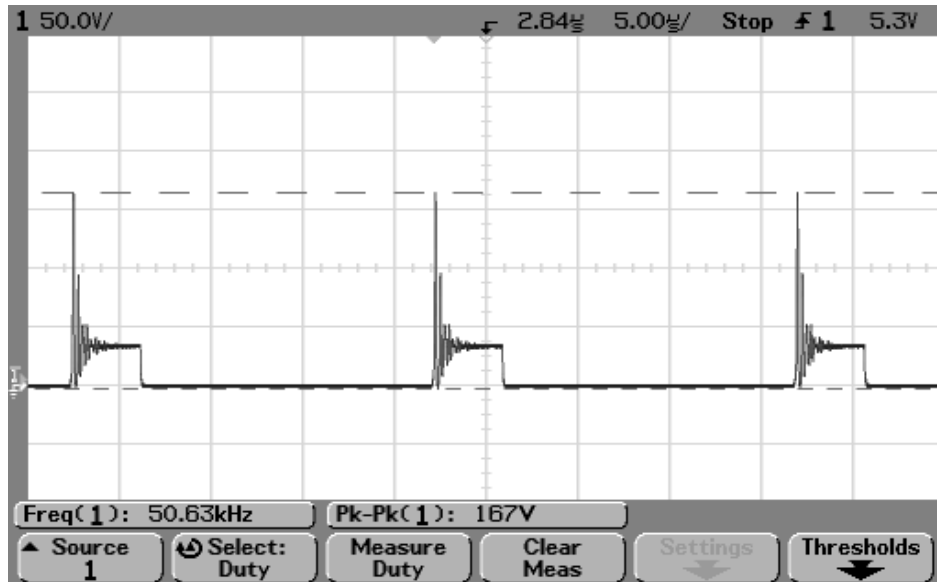

V_{DS} with a Load, without Snubber Capacitor, showing a Peak Value of about 167V

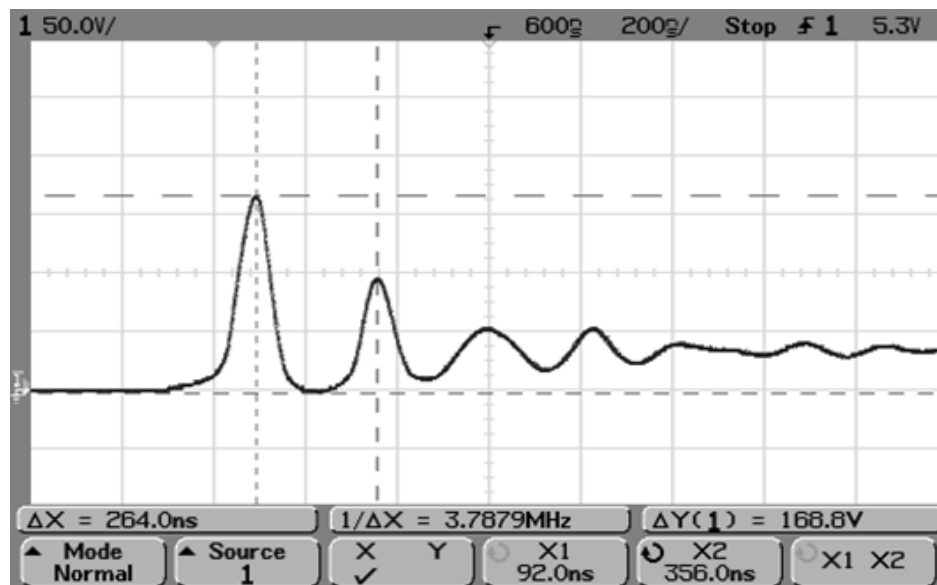

V_{DS} Turn-Off Transient, without Snubber Capacitor, is approximately 3.8MHz (note – while the turn-on transient is not shown, is about the same as the “with snubber” case because the snubber capacitor is essentially shorted when the MOSFET is turning on)

EE462L, Power Electronics, MOSFET Firing Circuit
Version Feb. 6, 2013

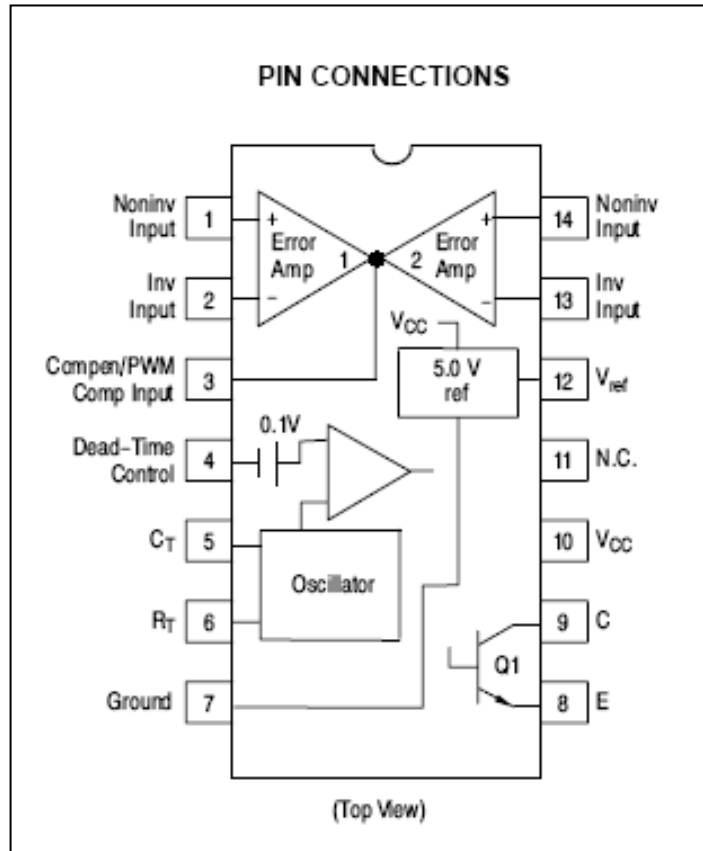

PWM Modulator (On Semiconductor MC34060A)

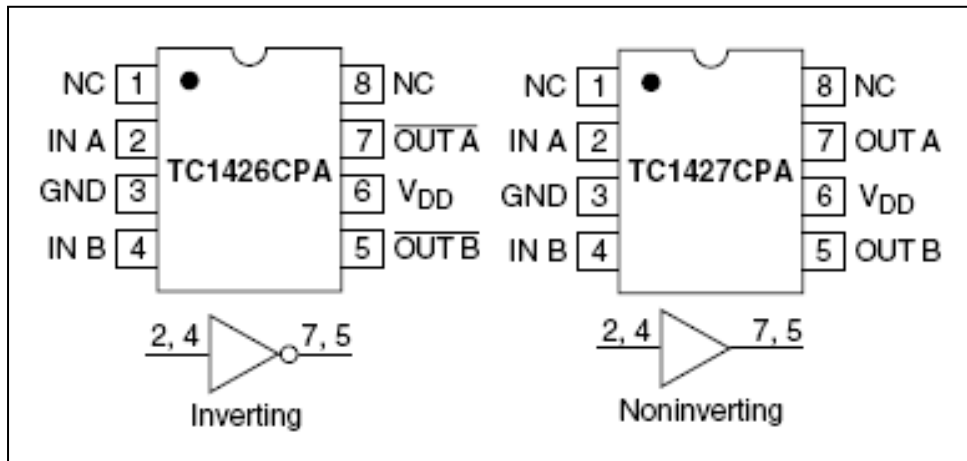

MOSFET Driver, Inverting and Non-Inverting, (MICROCHIP TC1426CPA and TC1427CPA, respectively)