

MEZZANINE BOARD v2.0		
Title	<Title> BLOCK DIAGRAM	
Size	Document Number	Rev
A	<Doc>	V1.2
Date:	Monday, December 31, 2007	Sheet 0 of 0

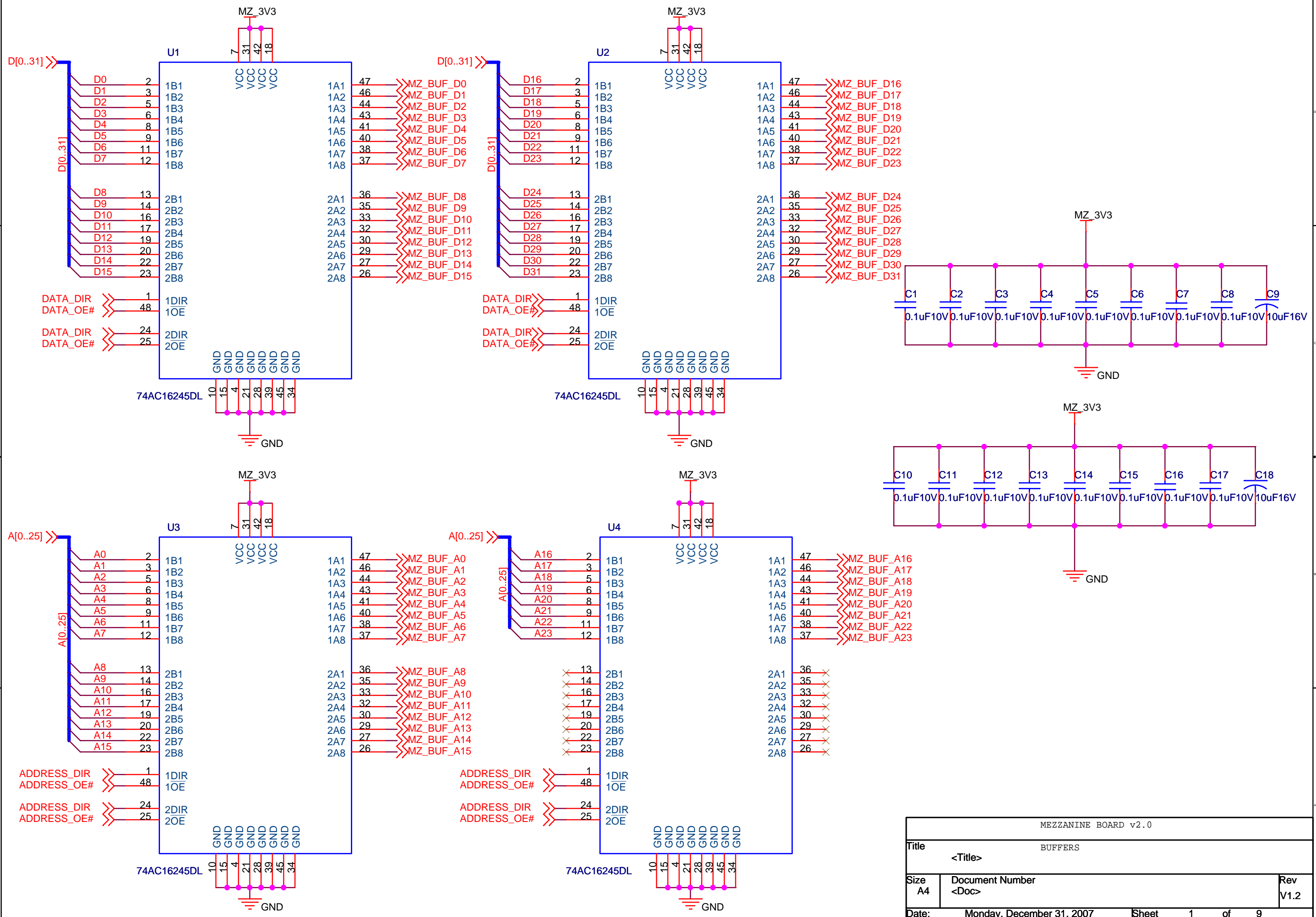

MEZZANINE BOARD v2.0		
Title	<Title> BUFFERS	
Size	Document Number	Rev
A4	<Doc>	V1.2
Date:	Monday, December 31, 2007	Sheet 1 of 9

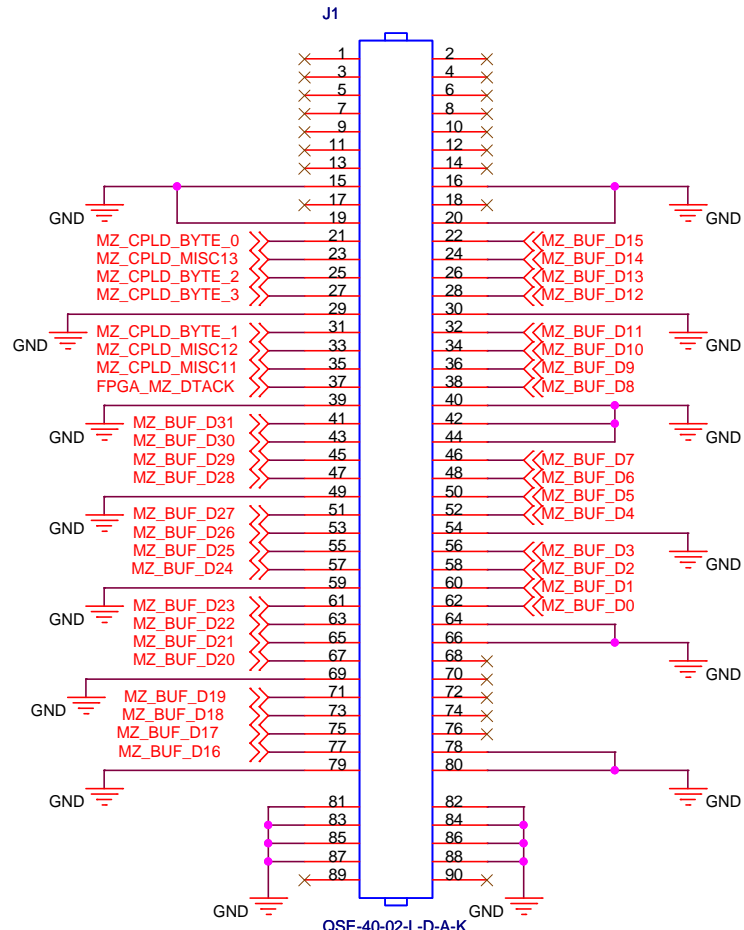

MEZZANINE CONNECTOR I

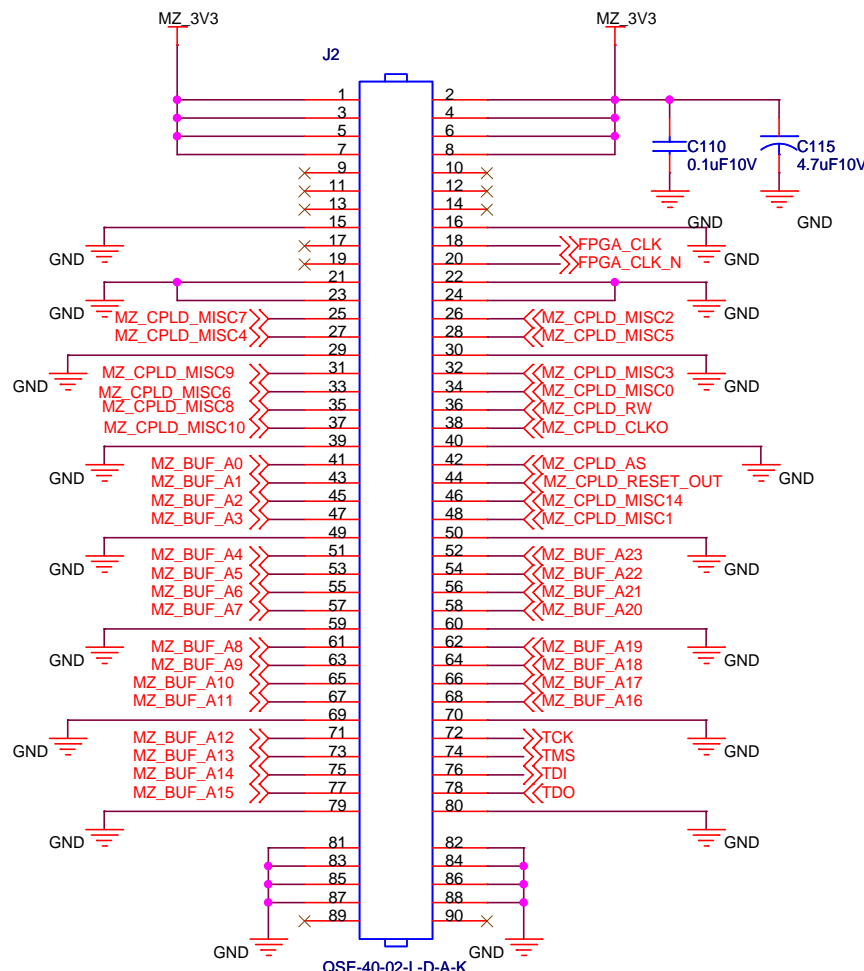

MEZZANINE CONNECTOR II

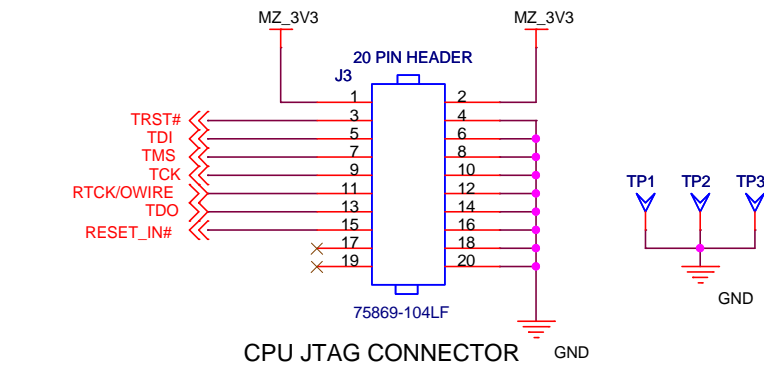

CPU JTAG CONNECTOR

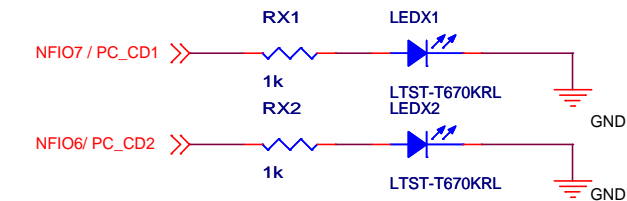

USER LEDs

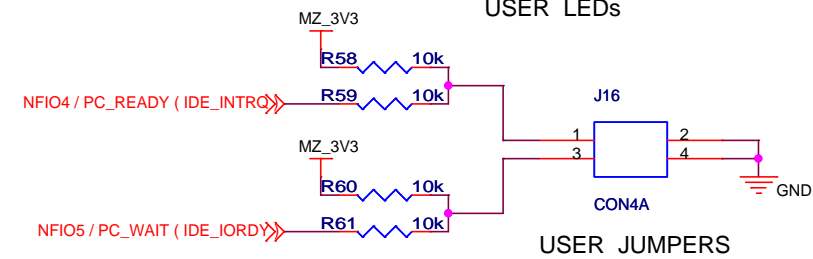

USER JUMPERS

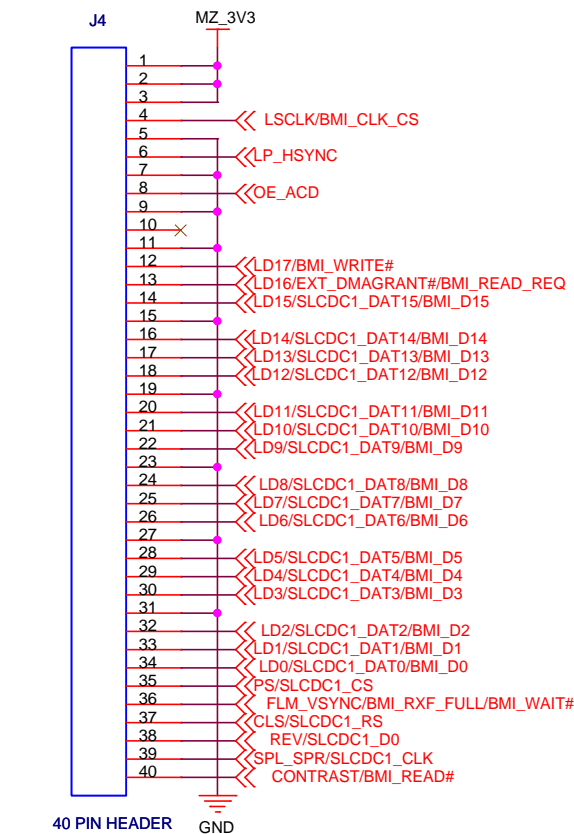
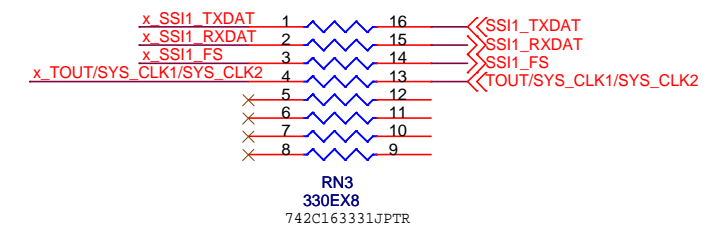

LCD CONNECTOR_TOP

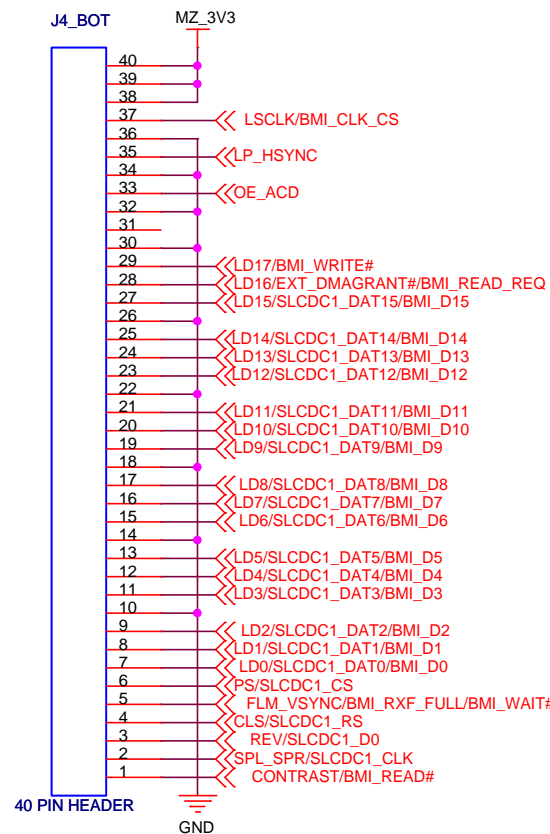

LCD CONNECTOR_BOT

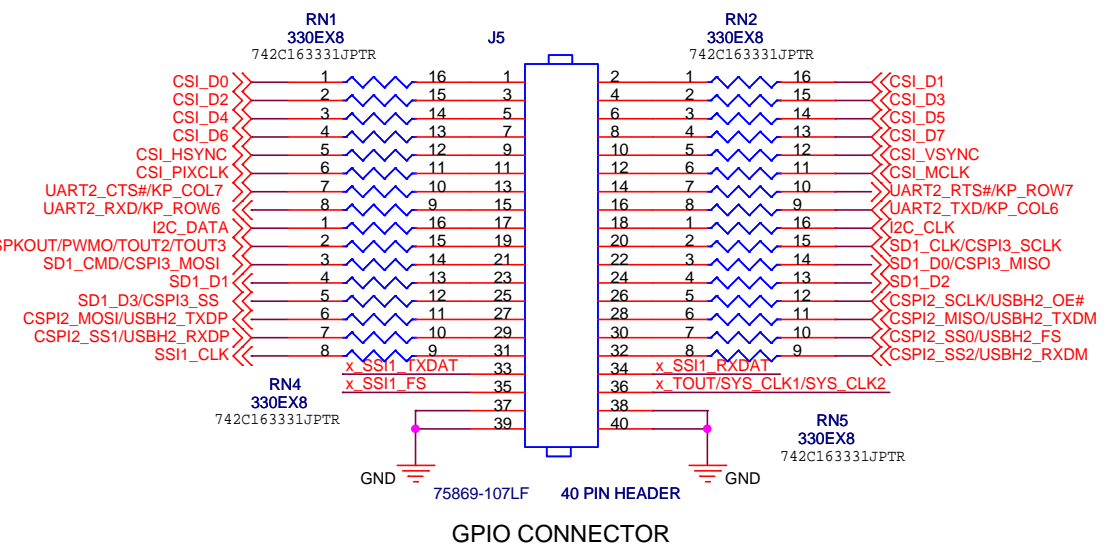

GPIO CONNECTOR

MEZZANINE BOARD v2.0		
Title	<Title>	CONNECTORS
Size	A3	Document Number <Doc>
Date	Monday, December 31, 2007	Rev V1.2
	Sheet 2	of 9

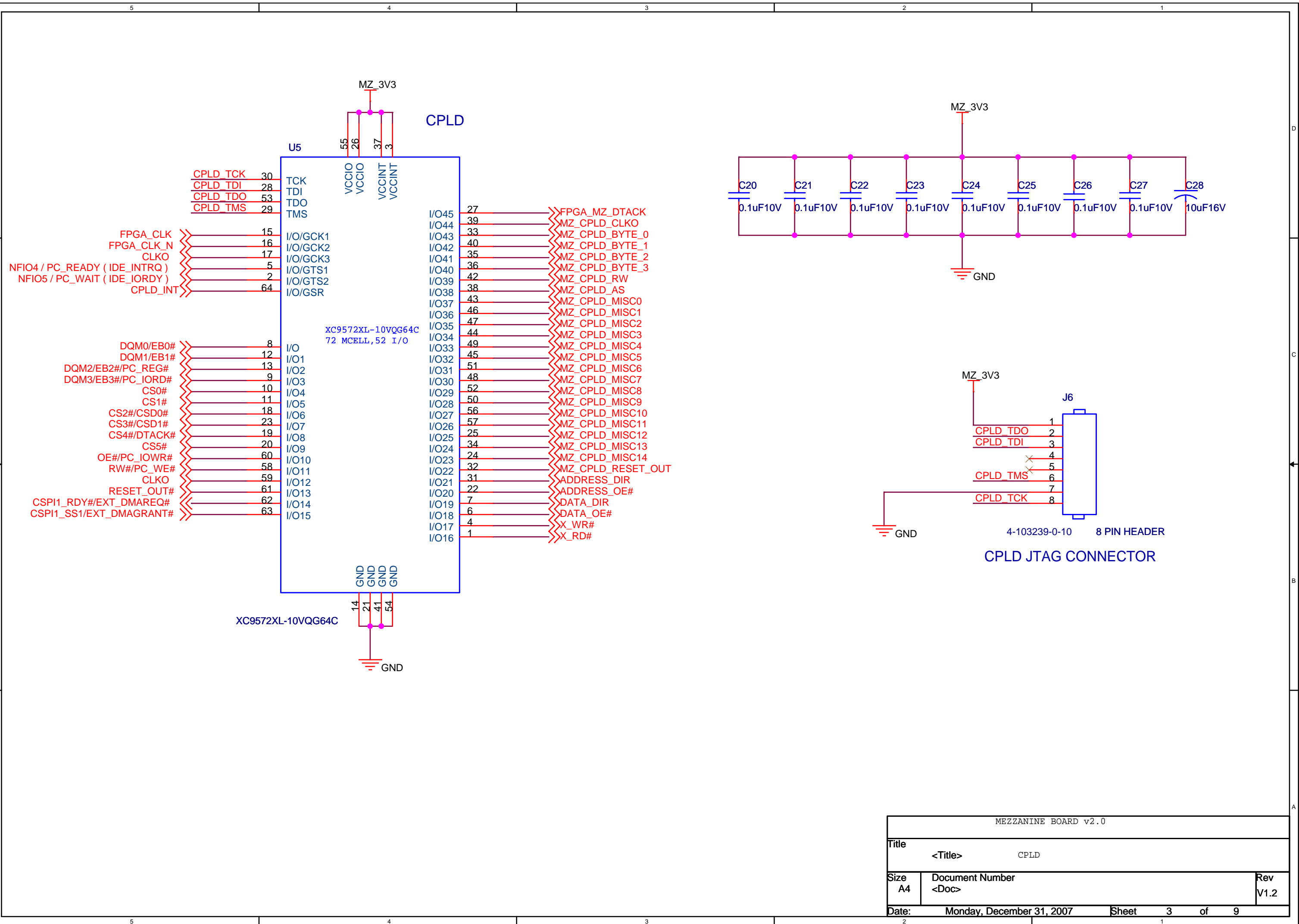

MEZZANINE BOARD v2.0		
Title		<Title> CPLD
Size	Document Number	Rev
A4	<Doc>	V1.2
Date:	Monday, December 31, 2007	Sheet 3 of 9

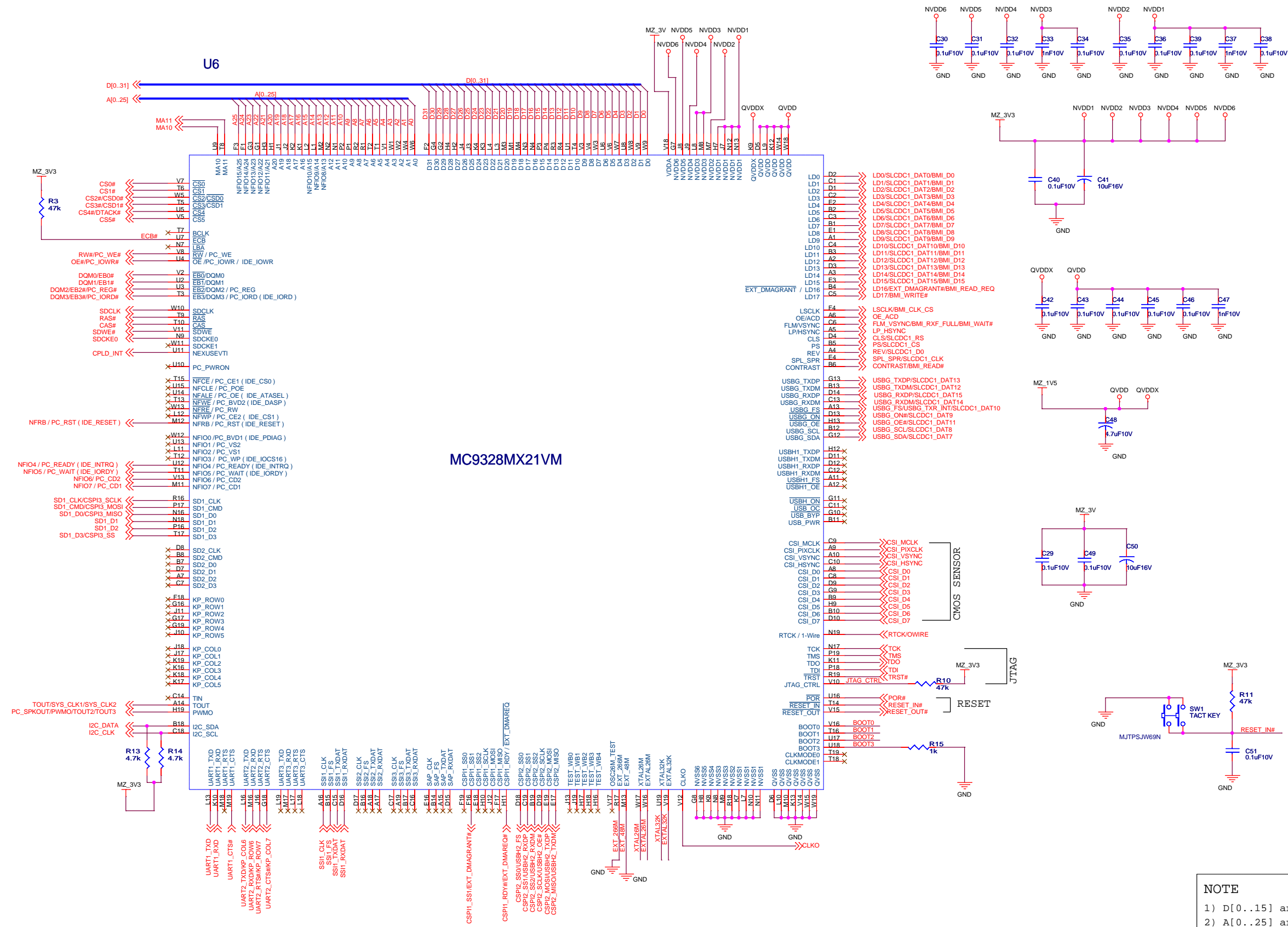

NOTE

- 1) D[0..15] are multiplexed with PC_D[0..15]
- 2) A[0..25] are multiplexed with PC_A[0..25]
- 3) A[1..10] are multiplexed with MA[0..9]
- 4) A[13..15] are multiplexed with NF_IO[8..10]
- 5) A[16..20] are multiplexed with SDBA[0..4]
- 6) A[21..25] are multiplexed with NF_IO[11..15]
- 7) A[21..24] are multiplexed with SDBIA[0..3]

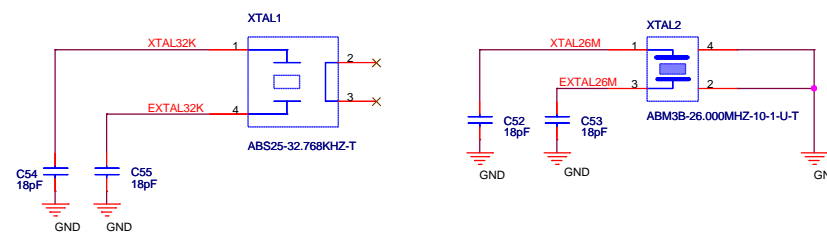

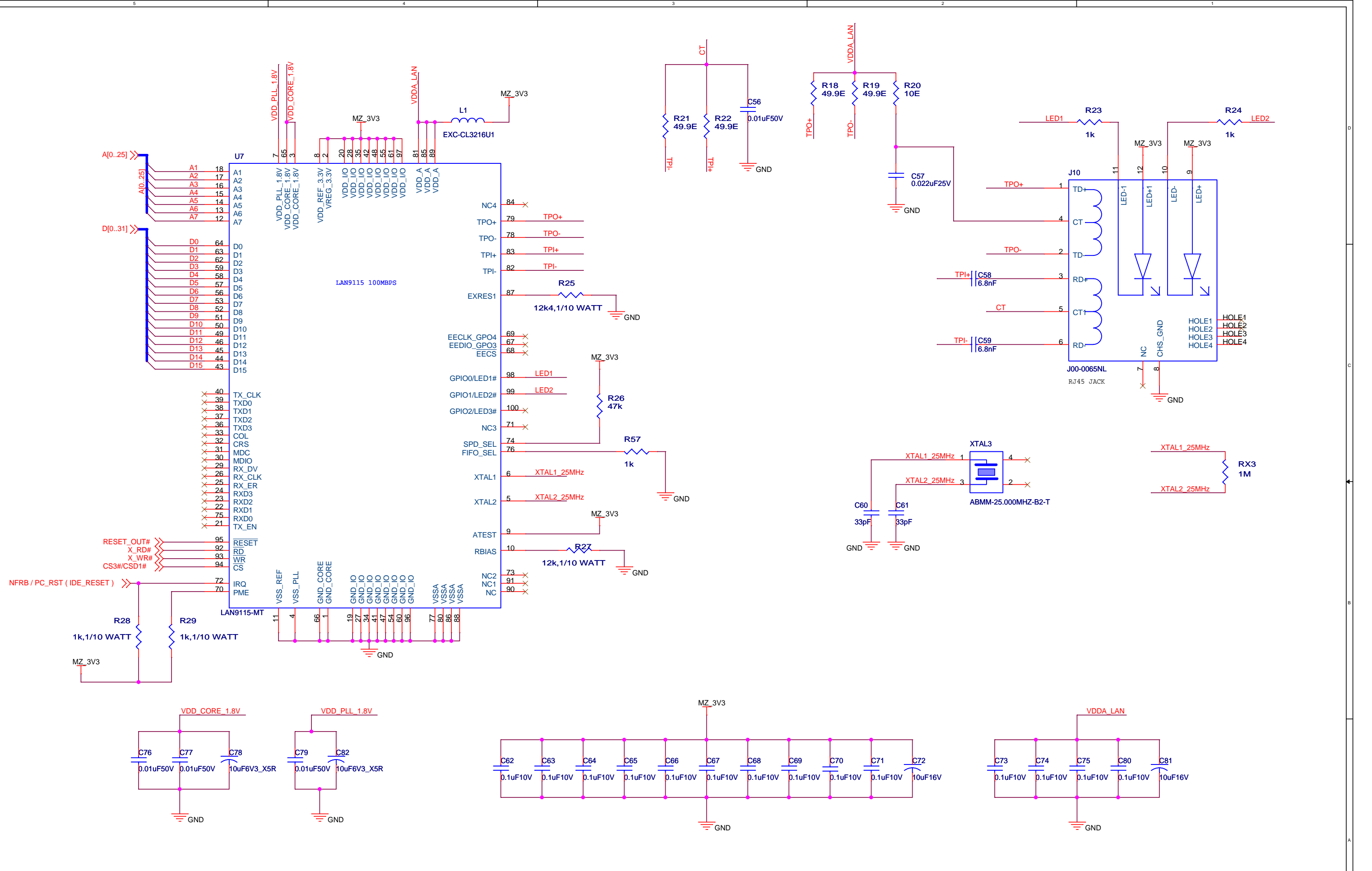

MEZZANINE BOARD v2.0		
Title	<Title> ETHERNET INTERFACE	
Size	Document Number	Rev
A3	<Doc>	V1.2
Date:	Monday, December 31, 2007	Sheet 5 of 9

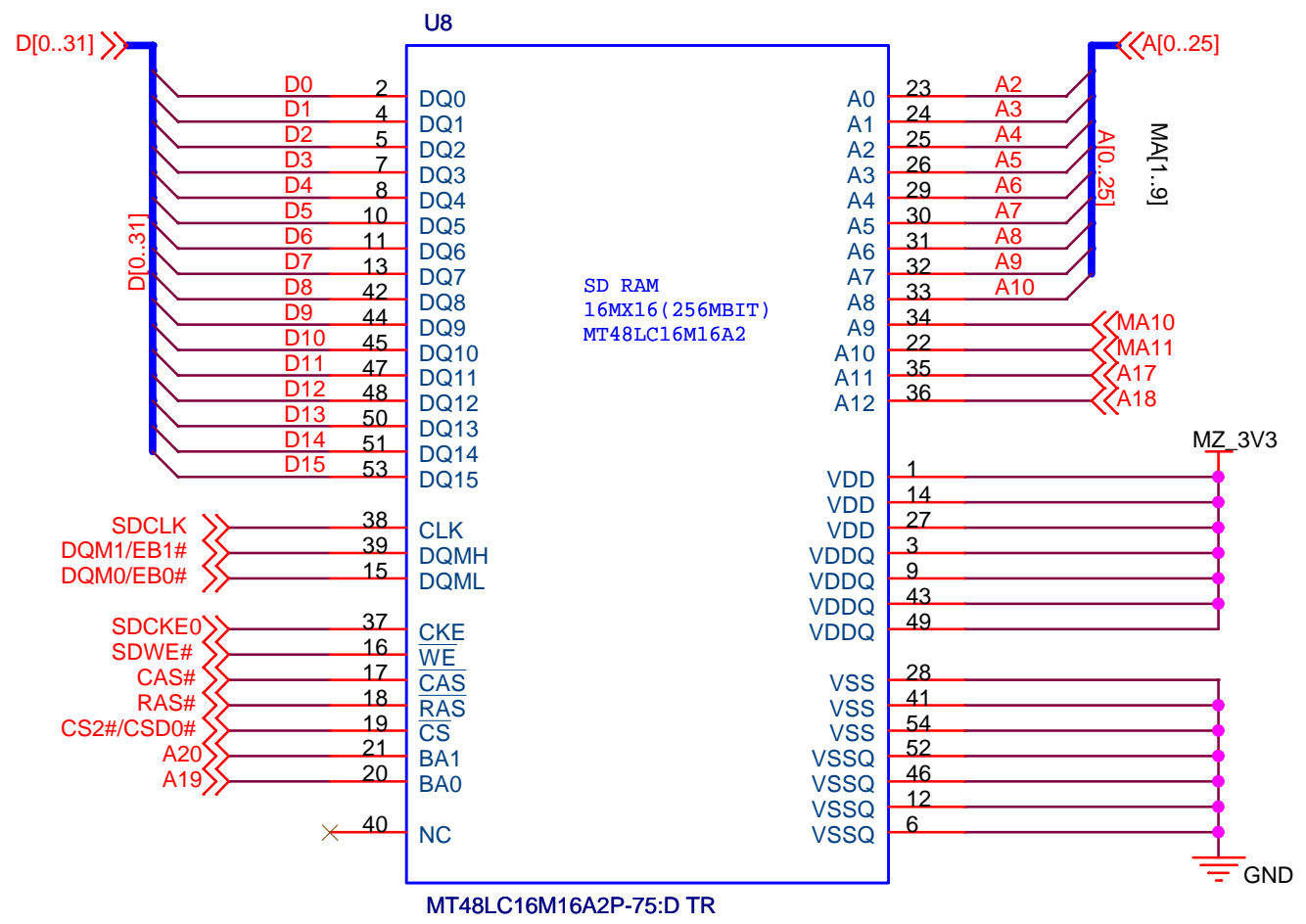

MT48LC16M16A2P-75:D TR

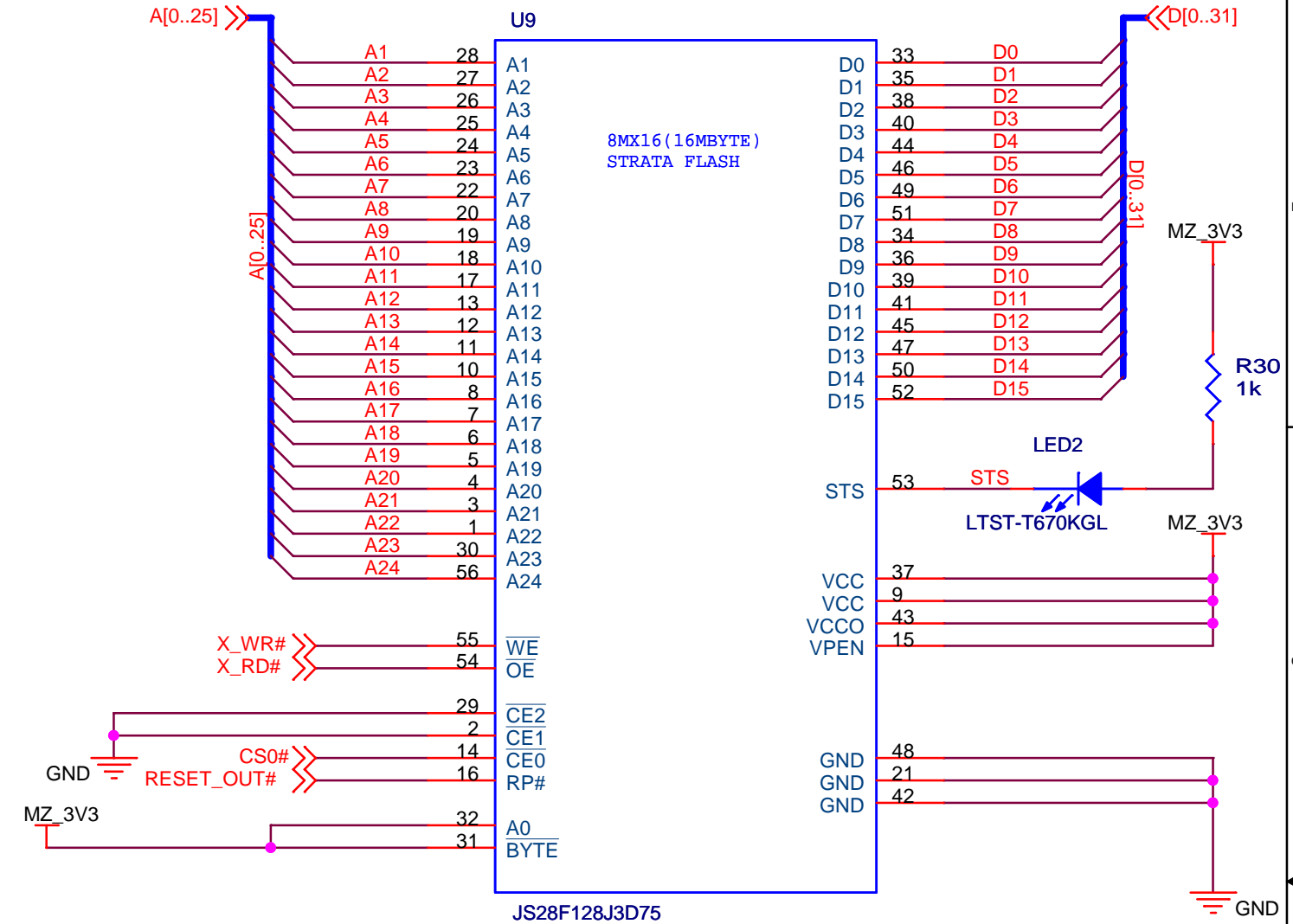

JS28F128J3D75

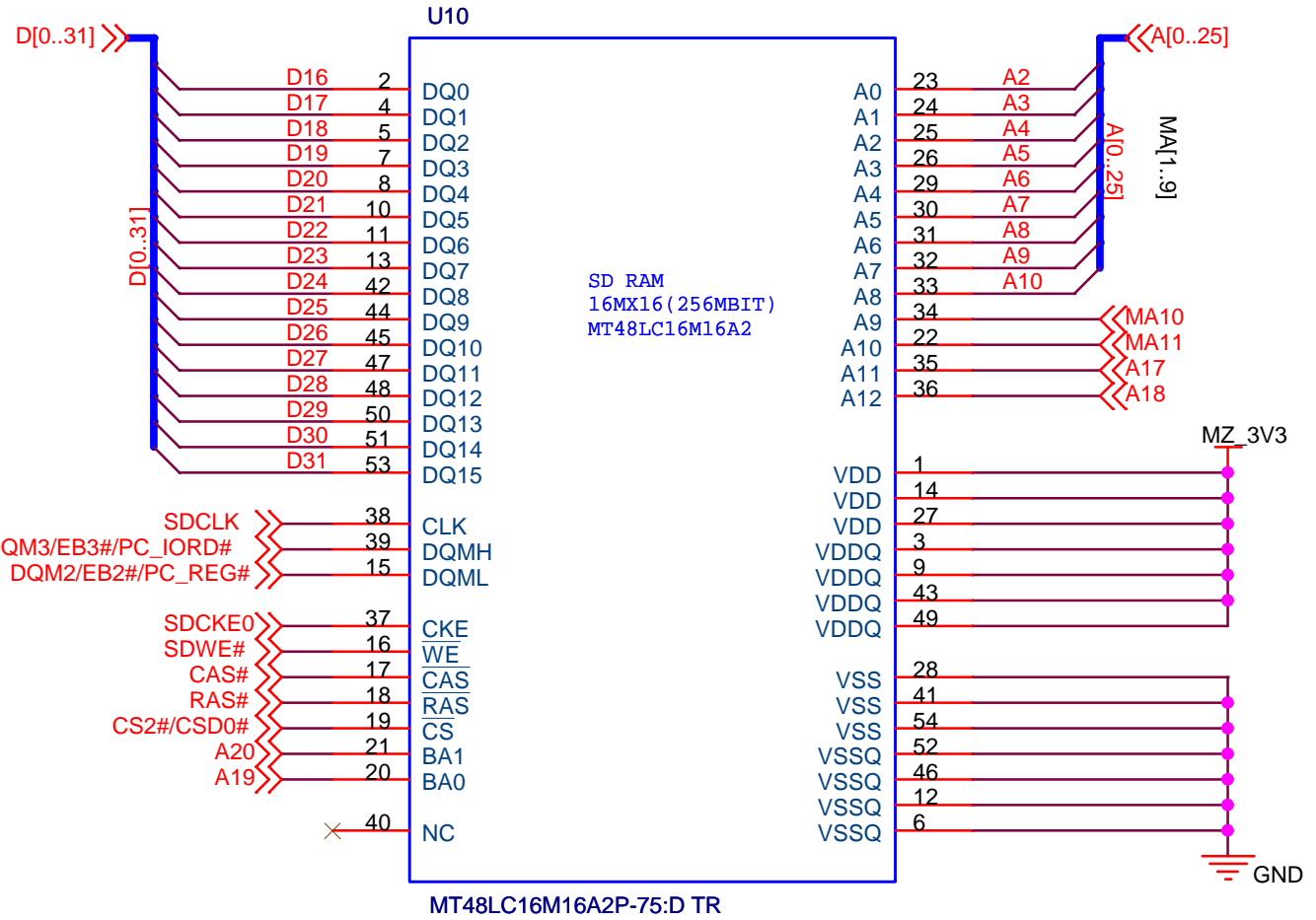

MT48LC16M16A2P-75:D TR

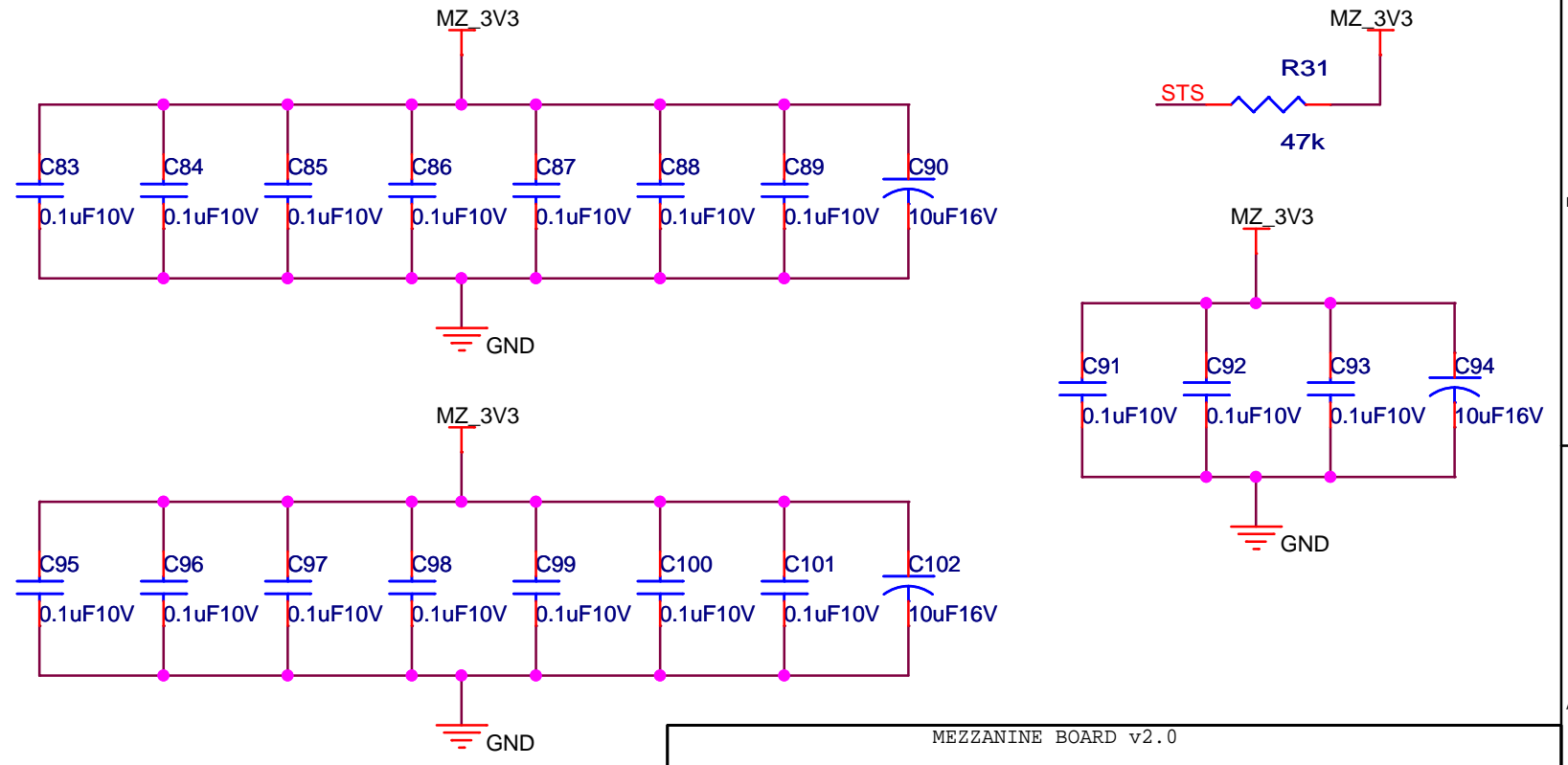

MEZZANINE BOARD v2.0		
Title	<Title> MEMORY INTERFACE	
Size	Document Number	Rev
A4	<Doc>	V1.2
Date:	Monday, December 31, 2007	Sheet 6 of 9

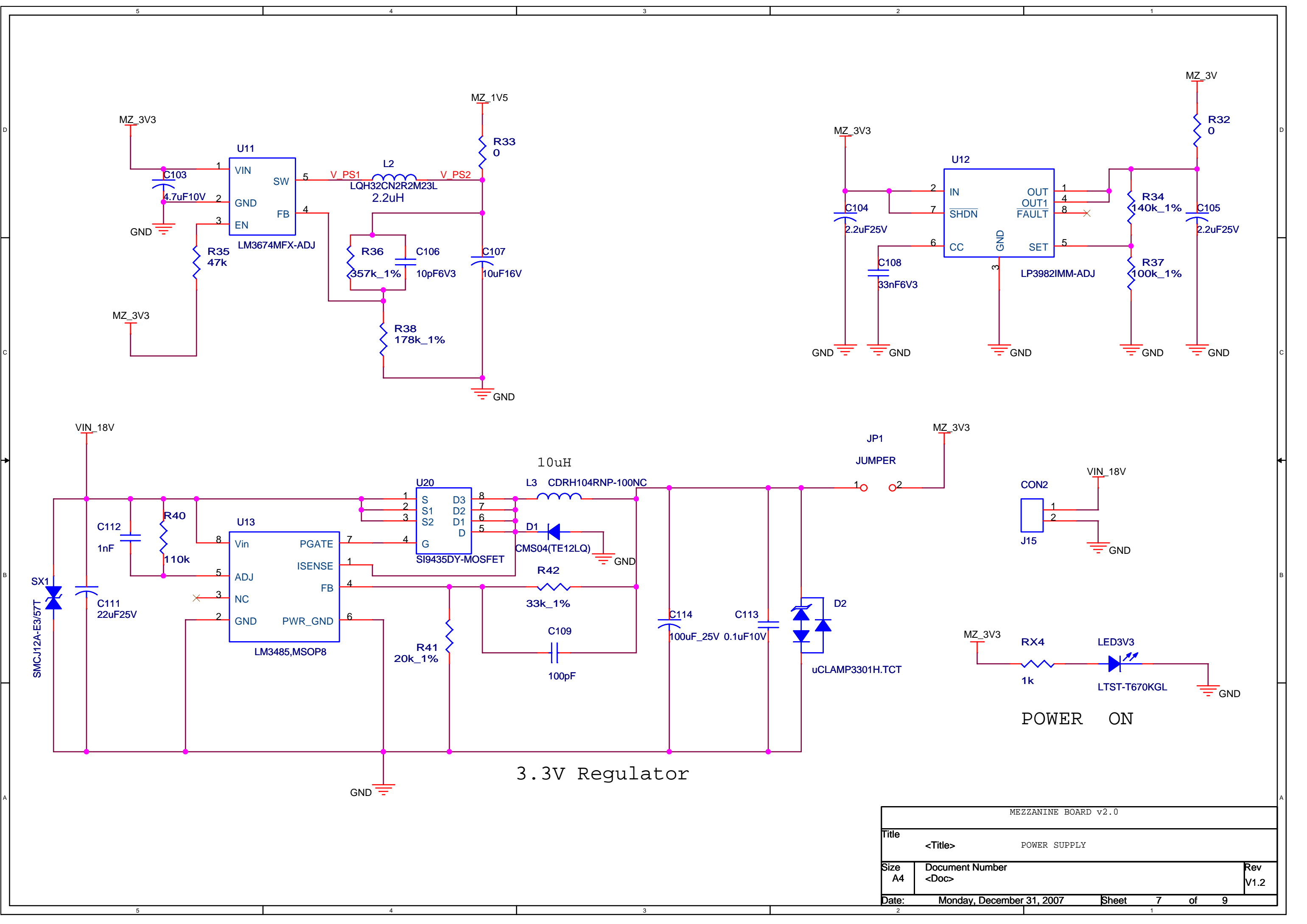

3.3V Regulator

POWER ON

MEZZANINE BOARD v2.0		
Title	<Title> POWER SUPPLY	
Size	Document Number	Rev
A4	<Doc>	V1.2
Date:	Monday, December 31, 2007	Sheet 7 of 9

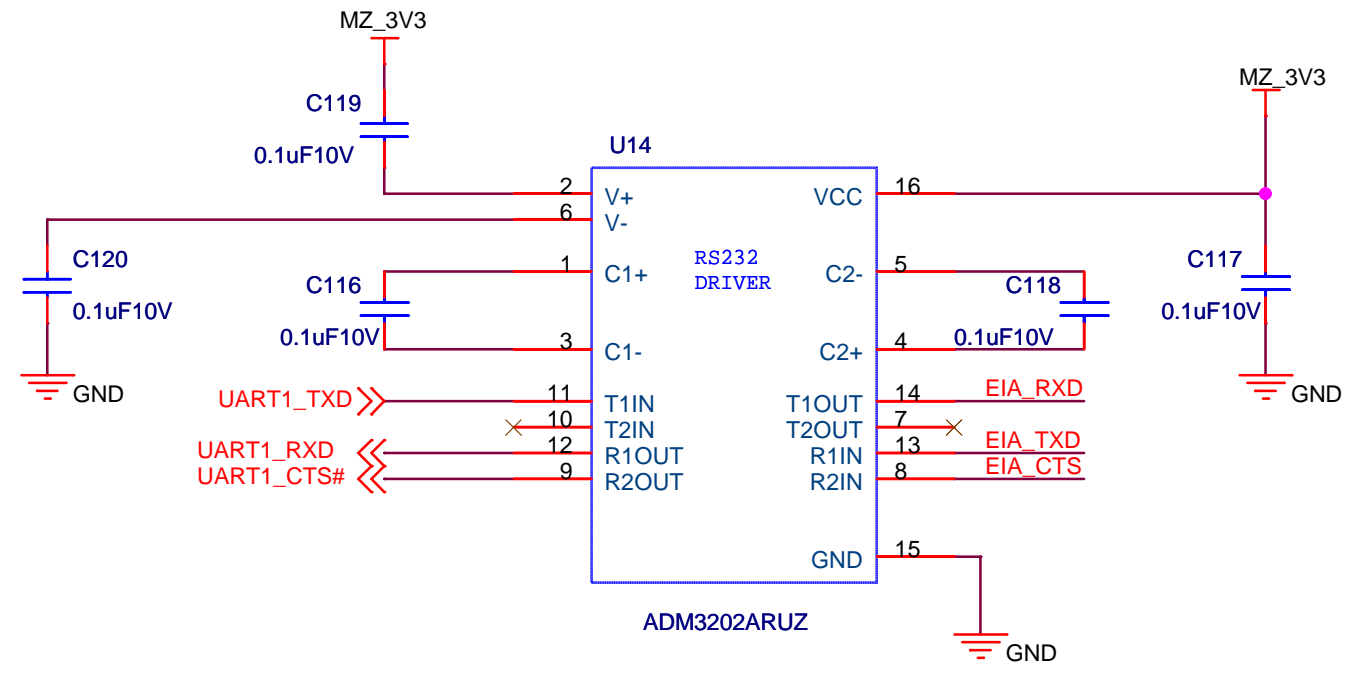

RS232 TO TTL CONVERTER

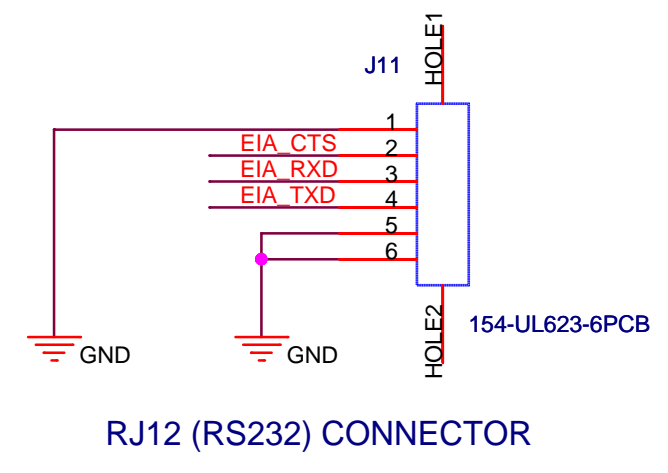

RJ12 (RS232) CONNECTOR

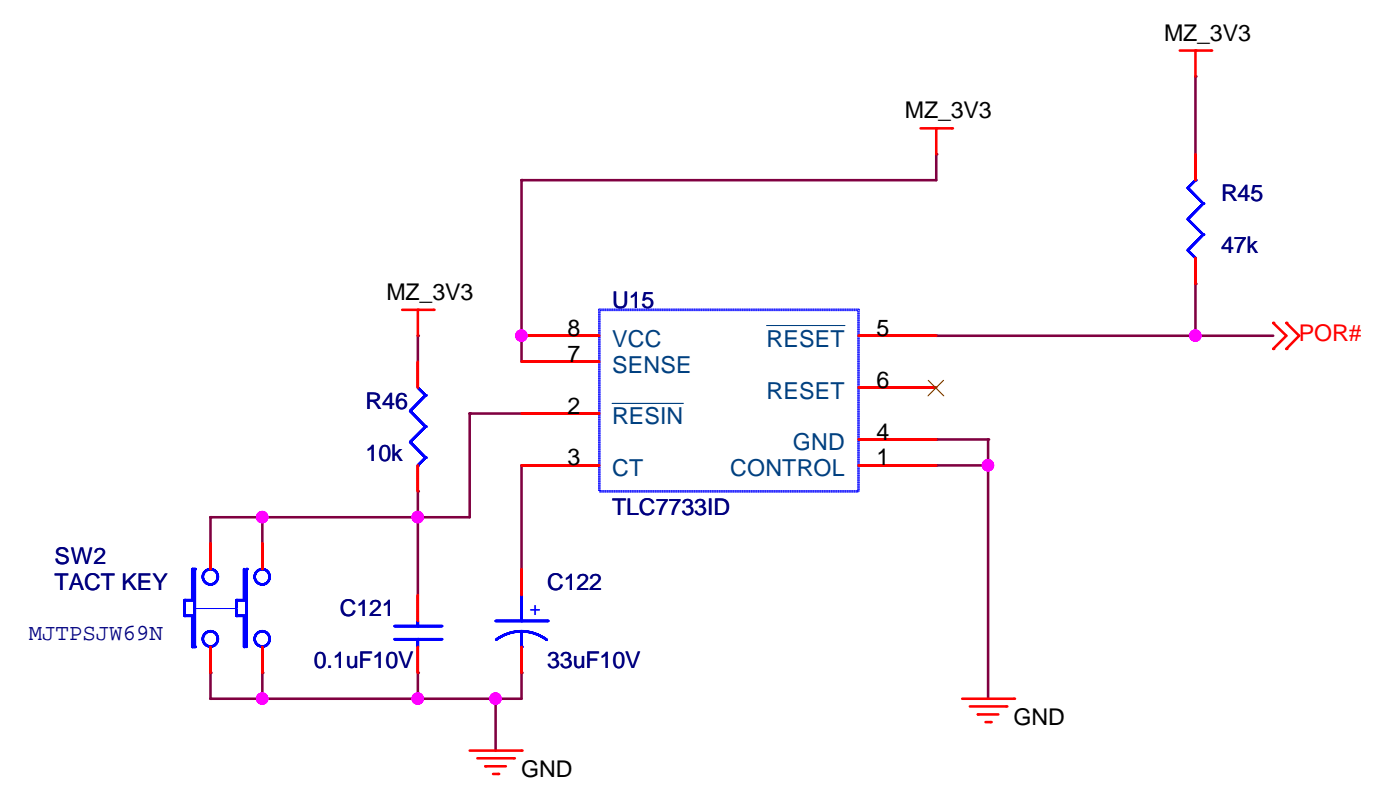

RESET GENERATOR

MEZZANINE BOARD v2.0		
Title	<Title>	RS232, RESET
Size	Document Number	Rev
A4	<Doc>	V1.2
Date:	Monday, December 31, 2007	Sheet 8 of 9

5

4

3

2

1

D

D

C

C

B

B

A

A

Title		
<Title>		
Size	Document Number	Rev
A3	<Doc>	<RevCode>
Date:	Monday, December 31, 2007	Sheet 10 of 10

5

4

3

2

1