

Vivado Design Suite Tutorial

Embedded Processor Hardware Design

UG940 (v2017.1) April 5, 2017



Revision History

The following table shows the revision history for this document.

Date	Version	Changes
04/05/2017	2017.1	Updated and validated for 2017.1.

Table of Contents

Revision History	2
Programming and Debugging Embedded Processors	5
Introduction	5
Hardware and Software Requirements	5
Tutorial Design Descriptions	5
Locating Tutorial Design Files	7
Lab 1: Building a Zynq-7000 AP SoC Processor Design	8
Introduction	8
Step 1: Start the Vivado IDE and Create a Project	8
Step 2: Create an IP Integrator Design	11
Step 3: Debugging the Block Design	17
Step 4: Generate HDL Design Files	20
Step 5: Implement Design and Generate Bitstream	22
Step 6: Export Hardware to SDK	24
Step 7: Create a Software Application	25
Step 8: Run the Software Application	27
Step 9: Connect to the Vivado Logic Analyzer	30
Conclusion	36
Lab Files	37
Lab 2: Zynq-7000 AP SoC Cross-Trigger Design	38
Introduction	38
Step 1: Start the Vivado IDE and Create a Project	38
Step 2: Create an IP Integrator Design	39
Step 3: Implement Design and Generate Bitstream	48
Step 4: Export Hardware to SDK	49
Step 5: Build Application Code in SDK	50
Step 6: Connect to Vivado Logic Analyzer	60
Step 7: Setting the Processor to Fabric Cross Trigger	62
Step 8: Setting the Fabric to Processor Cross-Trigger	65
Conclusion	66
Lab Files	66

Lab 3: Using the Embedded MicroBlaze Processor	67
Introduction	67
Step 1: Invoke the Vivado IDE and Create a Project.....	67
Step 2: Create an IP Integrator Design	68
Step 3: Memory-Mapping the Peripherals in IP Integrator.....	82
Step 4: Validate Block Design	85
Step 5: Generate Output Products	85
Step 6: Create a Top-Level Verilog Wrapper	87
Step 7: Take the Design through Implementation	87
Step 8: Exporting the Design to SDK.....	88
Step 9: Create a “Peripheral Test” Application	90
Step 10: Executing the Software Application on a KC705 Board.....	95
Step 11: Connect to Vivado Logic Analyzer	100
Step 12: Setting the MicroBlaze to Logic Cross Trigger	103
Step 13: Setting the Logic to Processor Cross-Trigger.....	106
Conclusion	107
Lab Files	107
Legal Notices.....	108
Please Read: Important Legal Notices.....	108

Programming and Debugging Embedded Processors

Introduction

This tutorial shows how to build a basic Zynq[®]-7000 All Programmable (AP) SoC processor and a MicroBlaze[™] processor design using the Vivado[®] Integrated Development Environment (IDE).

In this tutorial, you use the Vivado IP integrator tool to build a processor design, and then debug the design with the Xilinx[®] Software Development Kit (SDK) and the Vivado Integrated Logic Analyzer.



IMPORTANT: *The Vivado IP integrator is the replacement for Xilinx Platform Studio (XPS) for embedded processor designs, including designs targeting Zynq-7000 AP SoC devices and MicroBlaze[™] processors. XPS only supports designs targeting MicroBlaze processors, not Zynq-7000 AP SoC devices.*

Hardware and Software Requirements

This tutorial requires that Vivado Design Suite software (System Edition) release is installed. See the *Vivado Design Suite User Guide: Release Notes, Installation, and Licensing* ([UG973](#)) for a complete list and description of the system and software requirements.

The following Platform boards and cables are also needed:

- Xilinx Zynq-7000 AP SoC ZC702 board for Lab 1, and Lab 2
- Xilinx Kintex – 7 KC705 board for Lab 3
- One USB (Type A to Type B)
- JTAG platform USB Cable or Digilent Cable
- Power cable to the board

Tutorial Design Descriptions

No design files are required for these labs, if step-by-step instructions are followed as outlined; however, for subsequent iterations of the design or to build the design quickly, Tcl command files for these labs are provided. For cross-probing hardware and software, manual interaction with Vivado and Platform boards is necessary. No Tcl files are provided for that purpose.

Lab 1: Building a Zynq-7000 AP SoC Processor

[Lab 1: Building a Zynq-7000 AP SoC Processor Design](#) uses the Zynq-7000 AP SoC Processing Subsystem (PS) IP, and two peripherals that are instantiated in the Programmable Logic (PL) and connected using the AXI Interconnect. The Lab uses the following IP in the PL:

- A General Purpose IO (GPIO)
- A Block Memory
- An AXI BRAM Controller

Lab 1 shows how to graphically build a design in the Vivado IP integrator and use the Designer Assistance feature to connect the IP to the Zynq-7000 AP SoC PS.

After you construct the design, you mark nets for debugging the logic. Then you generate the Hardware Design Language (HDL) for the design as well as for the IP. Finally, you implement the design and generate a bitstream, then export the hardware description of the design to the Software Development Kit (SDK). You will use the SDK software to build and debug the design software, and learn how to connect to the hardware server (`hw_server`) application that SDK uses to communicate with the Zynq-7000 AP SoC processors. Then you perform logic analysis on the design with a connected board.

Design Files

The following design files are included in the zip file for this guide:

- `lab1.tcl`

See [Locating Tutorial Design Files](#).

Lab 2: Zynq-7000 AP SoC Cross Trigger Design

[Lab 2: Zynq-7000 AP SoC Cross-Trigger Design](#) requires that you have the Software Development Kit (SDK) software installed on your machine.

In Lab 2, you use the SDK software to build and debug the design software, and learn how to connect to the hardware server (`hw_server`) application that SDK uses to communicate with the Zynq-7000 AP SoC processors. Then, use the cross-trigger feature of the Zynq-7000 AP SoC processor to perform logic analysis on the design on the target hardware.

Design Files

The following design files are included in the zip file for this guide:

- `lab2.tcl`

See [Locating Tutorial Design Files](#).

Lab 3: Programming a MicroBlaze Processor

[Lab 3: Using the Embedded MicroBlaze Processor](#) uses the Xilinx MicroBlaze processor in the Vivado IP integrator to create a design and perform the same export to SDK, software design, and logic analysis.

Design Files

The following design files are included in the zip file for this guide:

- lab3.tcl

See [Locating Tutorial Design Files](#).

Locating Tutorial Design Files

Design data is in the associated [Reference Design File](#).

This document refers to the design data as <Design_Files>.

Lab 1: Building a Zynq-7000 AP SoC Processor Design

Introduction

In this lab you create a Zynq®-7000 AP SoC processor based design and instantiate IP in the processing logic fabric (PL) to complete your design. Then you mark signals to debug in the Vivado® Logic Analyzer. Finally, you take the design through implementation, generate a bitstream, and export the hardware to SDK. In SDK you create a Software Application that can be run on the target hardware. Breakpoints are added to the code to cross-probe between hardware and software.

If you are not familiar with the Vivado Integrated Development Environment Vivado (IDE), see the *Vivado Design Suite User Guide: Using the Vivado IDE* ([UG893](#)).

Step 1: Start the Vivado IDE and Create a Project

1. Start the Vivado IDE by clicking the Vivado desktop icon or by typing **vivado** at a terminal command line.
2. From the **Quick Start** section, click **Create Project**, as shown in the the following figure:

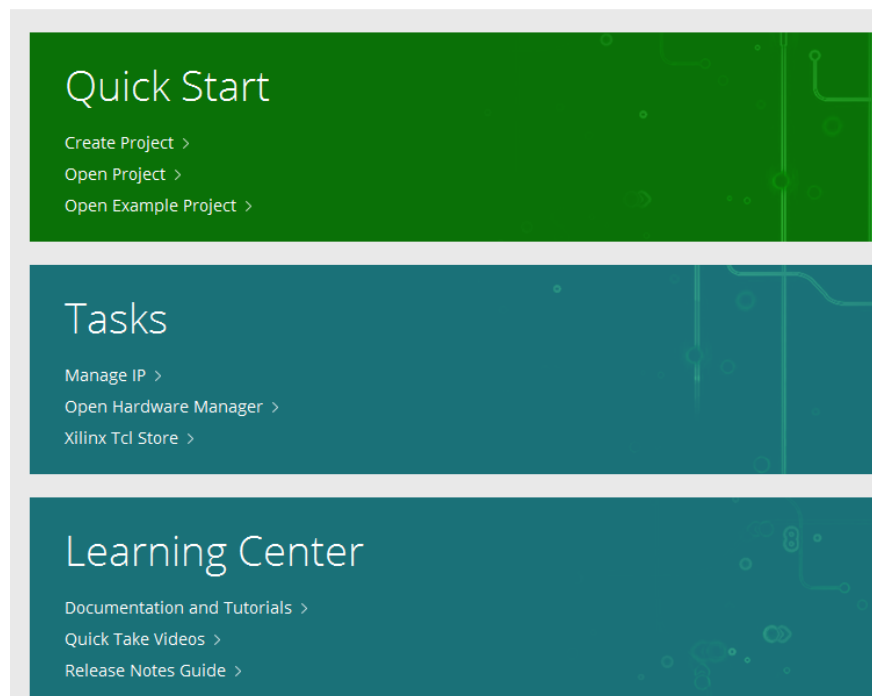

Figure 1: Vivado Quick Start Page

The New Project wizard opens.

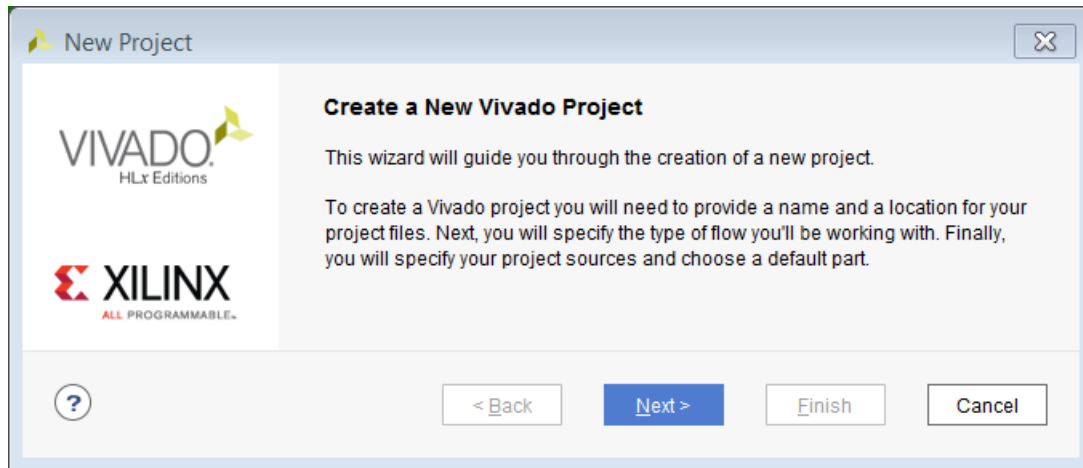

Figure 2: Create New Project Wizard

3. Click **Next**.

The Project Name dialog box opens.

4. In the **Project Name** dialog box, type a project name and select a location for the project files. Ensure that the **Create project subdirectory** check box is checked, and then click **Next**.
5. In the **Project Type** dialog box, select RL Project, and then click **Next**.
6. In the **Add Sources** dialog box, set the **Target language** to your desired language, Simulator language to **Mixed** and then click **Next**.
7. In the **Add Constraints** dialog box, click Next.
8. In the **Default Part** dialog box:
 - a. Select **Boards**.
 - b. From the **Board Rev** drop-down list, select **All** to view all versions of the supported boards.
 - c. Choose the version of the **ZYNQ-7 ZC702 Evaluation Board** that you are using.
 - d. Click **Next**.

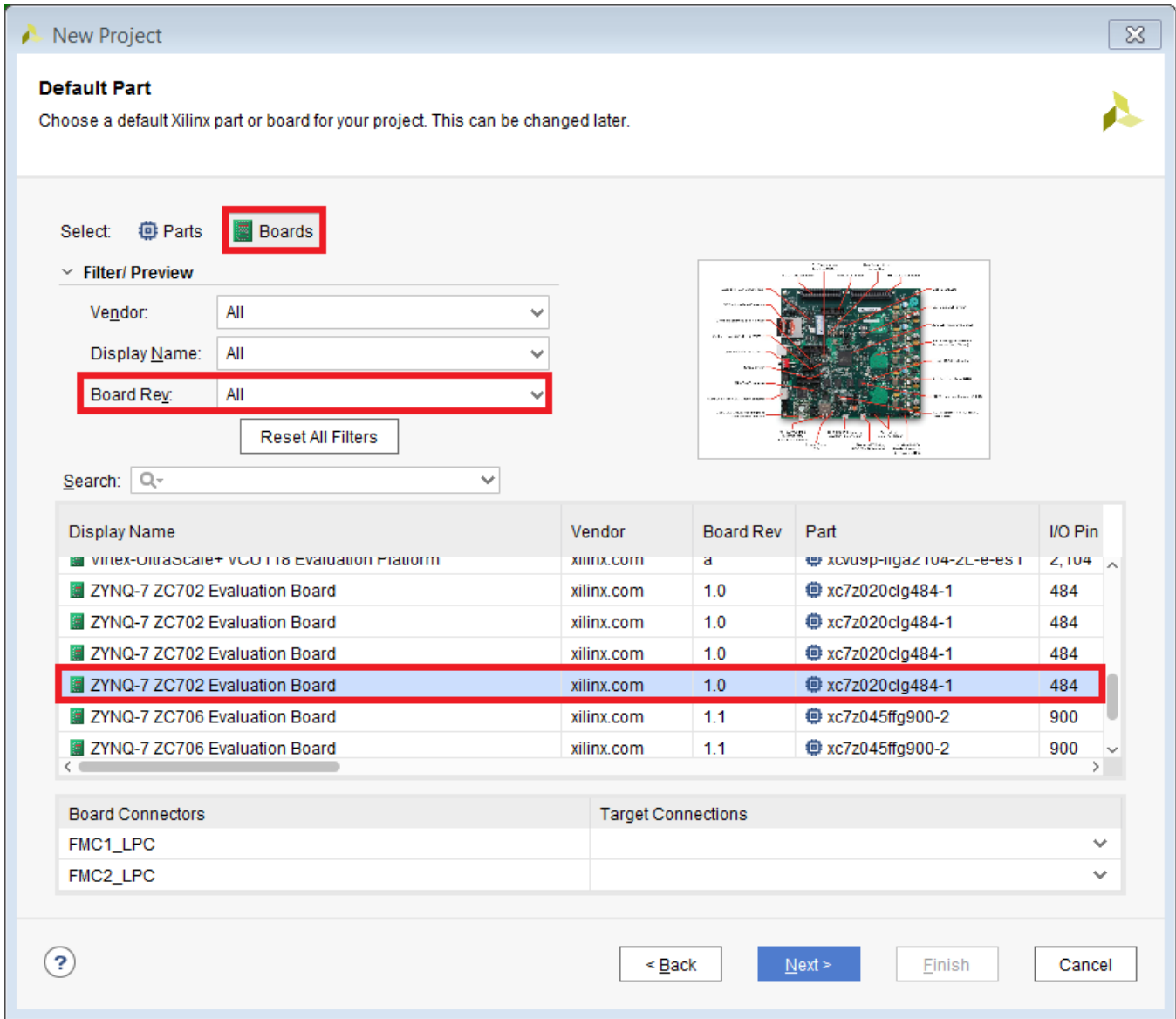

Figure 3: New Project:Default Part Dialog Box



CAUTION! Multiple versions of boards are supported in Vivado. Ensure that you are targeting the design to the right hardware.

- Review the project summary in the **New Project Summary** dialog box, and then click **Finish** to create the project.

Step 2: Create an IP Integrator Design

1. In the **Flow Navigator > IP Integrator**, select **Create Block Design**.
2. In the **Create Block Design** dialog box, specify a name for your IP subsystem design such as `zynq_design_1`. Leave the **Directory** field set to the default value of **<Local to Project>**, and leave the **Specify source set** field to its default value of **Design Sources**.

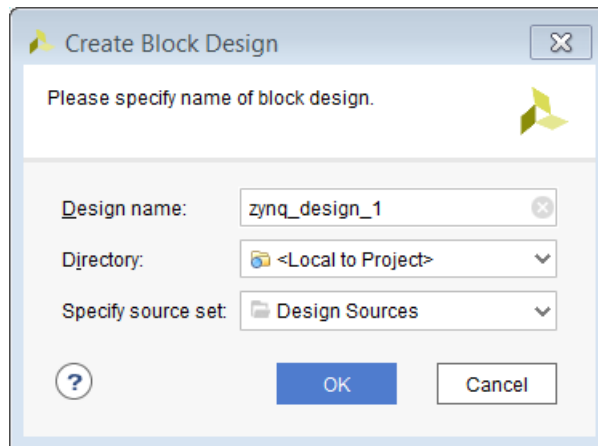

Figure 4: Create Block Design Dialog Box

3. Click **OK**.
4. In the block design canvas right-click, and select **Add IP**.
Alternatively, you can click the **Add IP** button in the IP integrator canvas.

This design is empty. Press the **+** button to add IP.

Figure 5: Add IP Link in IP Integrator Canvas

The IP catalog opens.

5. In the search field, type `zynq` to find the **ZYNQ7 Processing System** IP.
6. In the IP catalog, select the **ZYNQ7 Processing System**, and press **Enter** on the keyboard to add it to your design.

In the Tcl Console, you see the following message:

```
create_bd_cell -type ip -vlnv xilinx.com:ip:processing_system7:5.5
processing_system7_0
```

There is a corresponding Tcl command for all actions performed in the IP integrator block design. Those commands are not shown in this document; instead, the tutorial provides Tcl scripts to run each lab.

Note: *Tcl commands are documented in the Vivado Design Suite Tcl Command Reference Guide (UG835).*

- In the IP Integrator window, click the **Run Block Automation** link.

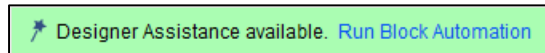

Figure 6: Run Block Automation link

The Run Block Automation dialog box opens, stating that the `FIXED_IO`, and `DDR` interfaces will be created for the Zynq-7000 AP SoC IP core. Also, note that the **Apply Board Preset** check box is checked. This is because the selected target board is ZC702.

- Ensure that both **Cross Trigger In** and **Cross Trigger Out** are disabled.

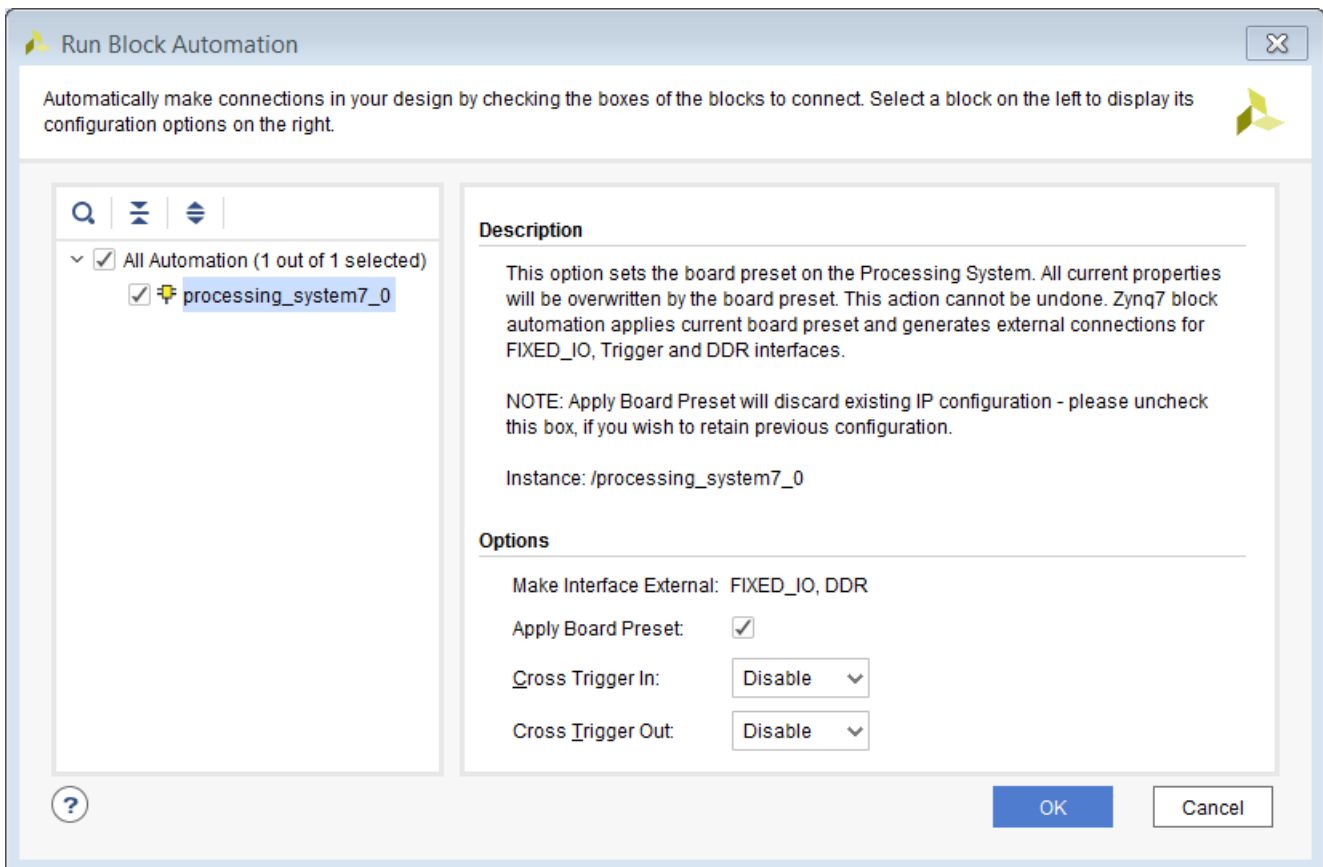

Figure 7: Zynq-7 Run Block Automation Dialog Box

9. Click **OK**.

After running block automation on the Zynq-7000 AP SoC processor, the IP integrator diagram looks as follows:

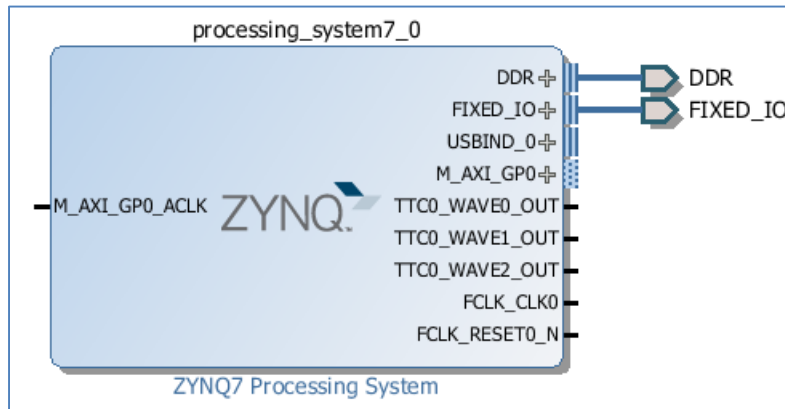

Figure 8: Zynq-7000 AP SoC Processing System after Running Block Automation

Now you can add peripherals to the processing logic (PL).

10. Right-click in the IP integrator diagram, and select **Add IP**.

11. In the search field, type `gpi` to find the **AXI GPIO**, and then press **Enter** to add it to the design.

12. Similarly, add the **AXI BRAM Controller**.

Your Block Design window will look like the following figure. The relative positions of the IP might vary.



TIP: You can zoom in and out in the Diagram Panel using the **Zoom In** (or **Ctrl+=**) and **Zoom Out** (or **Ctrl+-**) tools.

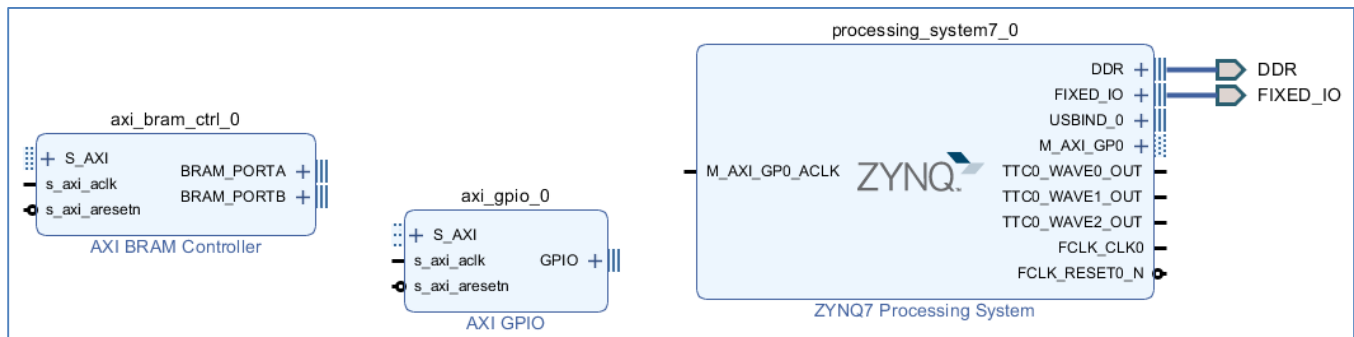

Figure 9: Block Design after Instantiating IP

Use Designer Assistance

Designer Assistance helps connect the AXI GPIO and AXI BRAM Controller to the Zynq-7000 AP SoC PS.

1. Click Run Connection Automation as shown in the following figure:

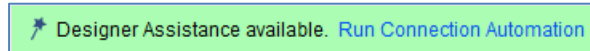

Figure 10: Run Connection Automation

The Run Connection Automation dialog box opens.

2. Select the **All Automation** (5 out of 5 selected) check box, as shown in the following figure:

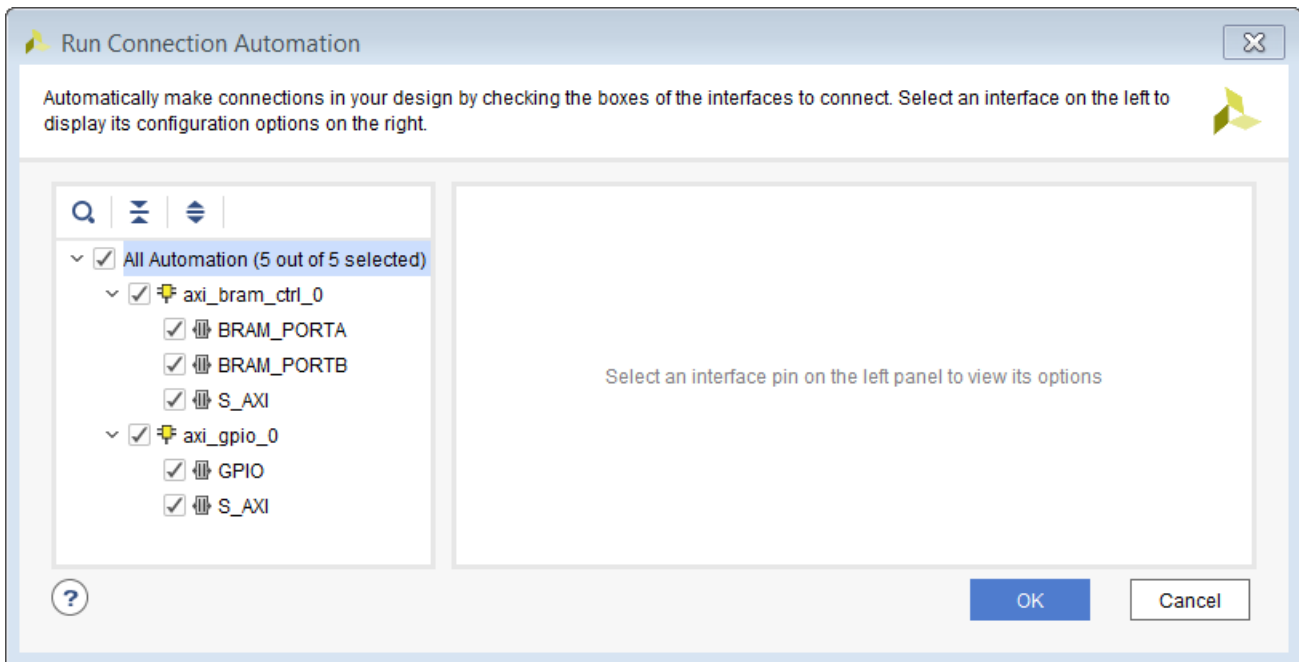

Figure 11: Run Connection Automation Message

As you select each interface for which connection automation is to be run, the description and options available for that interface appear in the right pane.

3. Click the `S_AXI` interface of the `axi_bram_ctrl_0`, and ensure that its **Clock Connection** (for unconnected clks) field is set to the default value of **Auto**.

This value selects the default clock, `FCLK_CLK0`, generated by the PS7 for this interface.

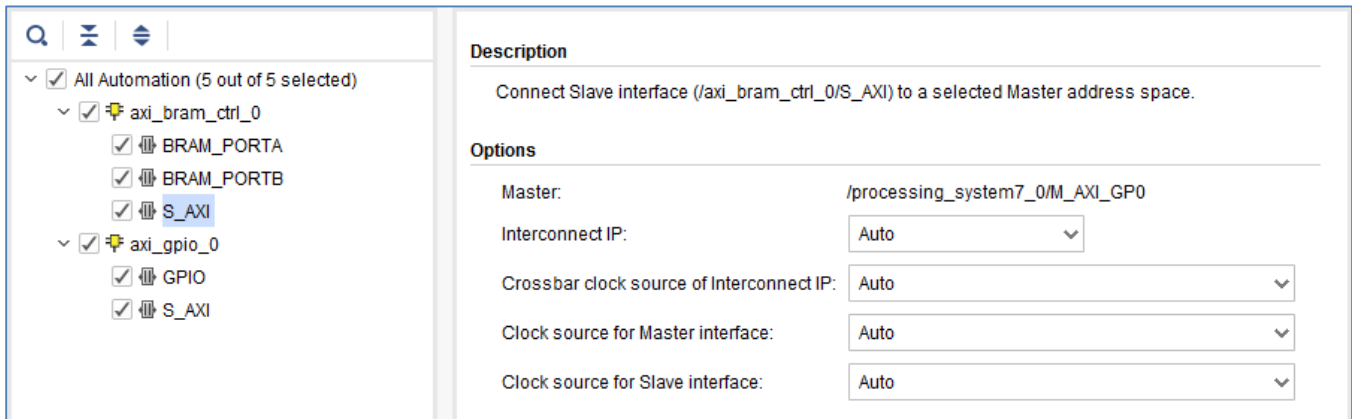

Figure 12: S_AXI Connection Automation Options for axi_bram_ctrl_0

- For the GPIO interface of the axi_gpio_0 instance, select the **leds_4bits** from the **Select Board part Interface** drop down list.

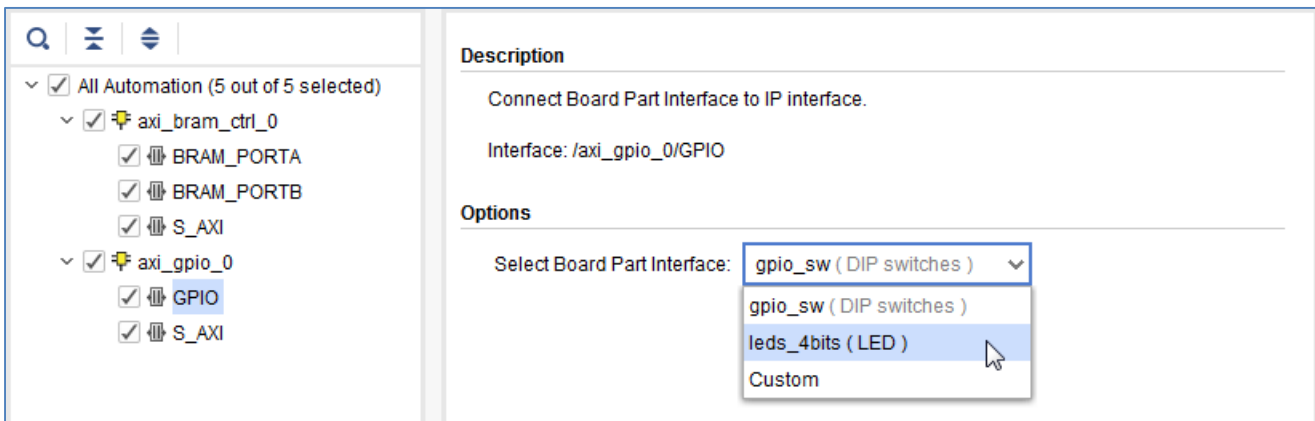

Figure 13: Select leds_4bits as for GPIO interface of axi_gpio_0

- For the S_AXI interface of axi_gpio_0 instance, leave the **Clock Connection** (for unconnected clks) field to **Auto**.

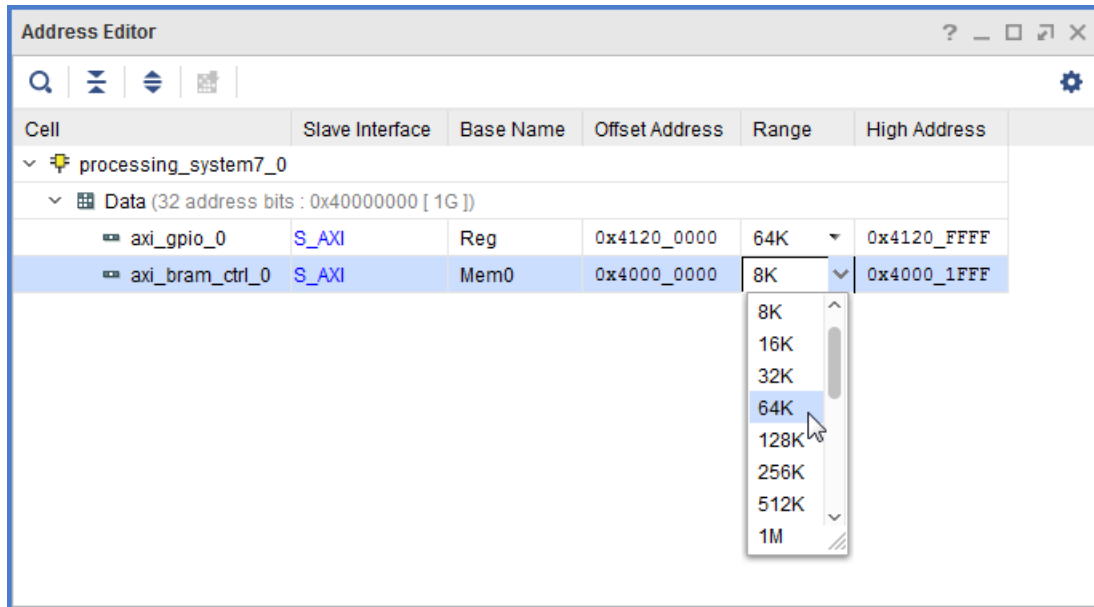



Figure 16: Change Range of axi_bram_ctrl to 64K

9. Click the Diagram tab to go back to the block design.
10. Click the **Regenerate Layout** button  to regenerate an optimal layout of the block design.

Step 3: Debugging the Block Design

You now add hooks in the design to debug nets of interest.

1. To debug the master/slave interface between the AXI Interconnect IP (ps7_0_axi_periph) and the GPIO core (axi_gpio_0), in the Diagram view, select the interface, then right-click and select **Debug**.

In the Block Design canvas on the net that you selected in the previous step, a small bug icon  appears, indicating that the net has been marked for debug. You can also see this in the Design Hierarchy view, as displayed in Figure 17, on the interface that you chose to mark for debug.

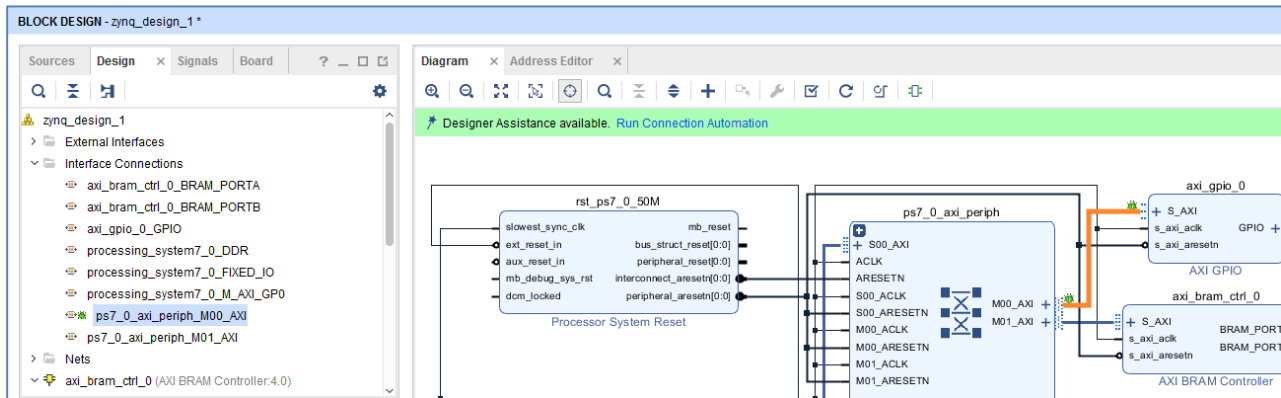

Figure 17: Design Hierarchy: Bug Icon on Nets being Debugged

When a net is marked for debug, the Designer Assistance link in the banner of the block design canvas becomes active.

2. Click **Run Connection Automation**.

The All Automation is selected by default with the various options for AXI Read/Write signals set, as shown in the following figure:

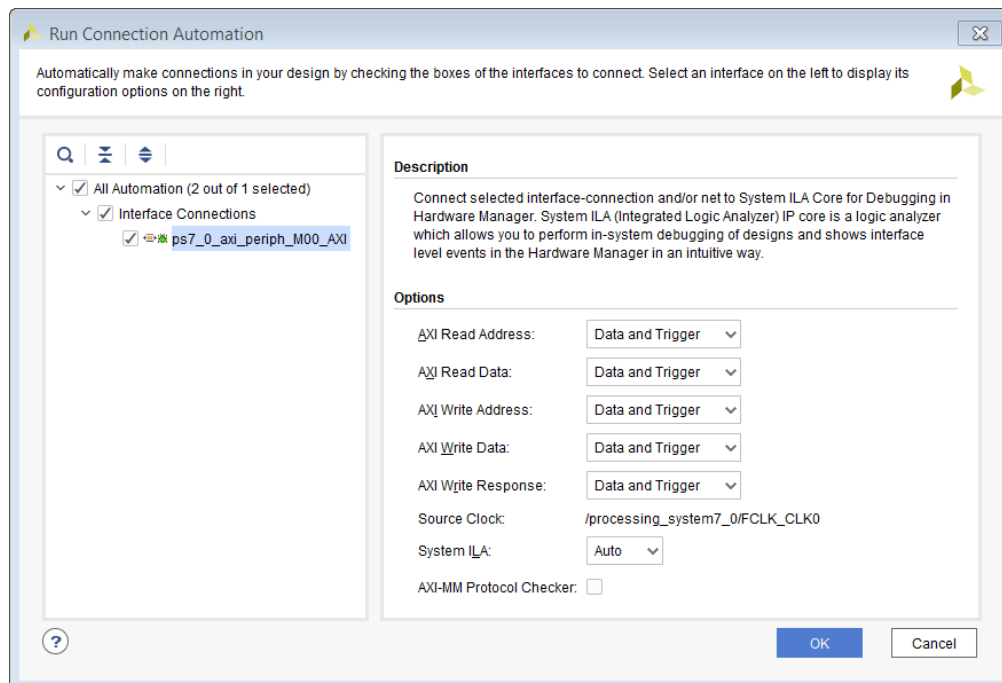

Figure 18: Run Connection Automation Dialog box for inserting a System ILA IP

3. Click **OK**.

A System ILA IP is instantiated on the block design which is appropriately configured to debug the AXI Interface marked for debug. The net marked for debug is connected to this System ILA IP and an appropriate clock source is connected to the `clk` pin of the System ILA IP. The clock source is the same clock domain to which the interface signal belongs

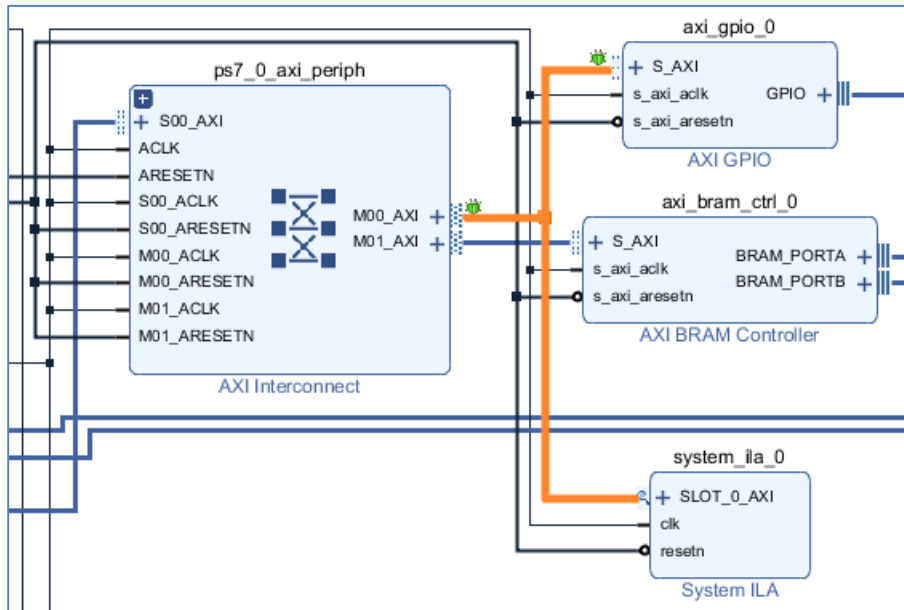

Figure 19: System ILA IP Connected to the Interface Net Being Debugged

4. From the toolbar, run Design-Rules-Check (DRC) by clicking the **Validate Design** button . Alternatively, you can do the same from the menu by:
 - Selecting **Tools > Validate Design** from the menu.
 - Right-clicking in the Diagram window and selecting **Validate Design**.

The Validate Design dialog box opens to notify you that there are no errors or critical warnings in the design.

The Tcl Console shows the following warning.

WARNING: [BD 41-1781] Updates have been made to one or more nets/interface connections marked for debug.

Debug nets, which are already connected to System ILA IP core in the block-design, will be automatically available for debug in Hardware Manager.

For unconnected Debug nets, please open synthesized design and use 'Set Up Debug' wizard to insert, modify or delete Debug Cores. Failure to do so could result in critical warnings and errors in the implementation flow.

Block designs can use the instantiation flow, where a System ILA or ILA IP is instantiated in the block design, or they can use the netlist insertion flow, where nets are only marked for debug but the debug core is inserted post-synthesis. This warning message can be ignored if the instantiation flow is being used (as in this lab).

5. Click **OK**.
6. From the Vivado menu, save the block design by selecting **File > Save Block Design**.

Alternatively, you can press **Ctrl + S** to save your block design or click the **Save** button  in the Vivado toolbar.

Step 4: Generate HDL Design Files

You now generate the HDL files for the design.

1. In the Sources window, right-click the top-level subsystem design and select **Generate Output Products**. This generates the source files for the IP used in the block design and the relevant constraints file.

You can also click **Generate Block Design** in the Flow Navigator to generate the output products.

The Generate Output Products dialog box opens, as shown in the following figure.

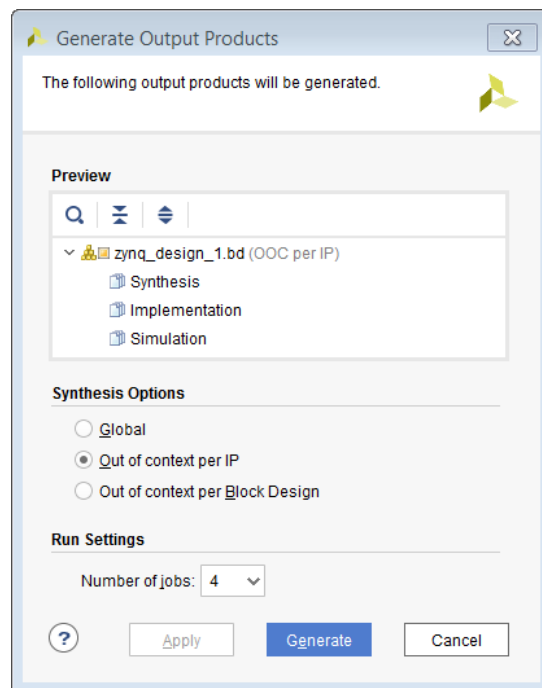

Figure 20: Generate Output Products Dialog Box

2. Leave all the settings to their default values. Click **Generate**.
3. The Generate Output Products dialog box opens informing that Out-of-context runs were launched.
4. Click **OK**.
5. Out-of-context runs can take a few minutes to finish. You can see the status of the runs by clicking on the Design Runs tab at the bottom of the Vivado IDE.
6. In the Sources window, right-click the top-level subsystem, **zynq_design_1**, and select **Create HDL Wrapper** to create an top level HDL file that instantiates the block design.

The Create HDL Wrapper dialog box opens, as shown in the following figure, and presents you with two options:

- The first option is to copy the wrapper to allow edits to the generated HDL file.
- The second option is to create a read-only wrapper file, which will be automatically generated and updated by Vivado.

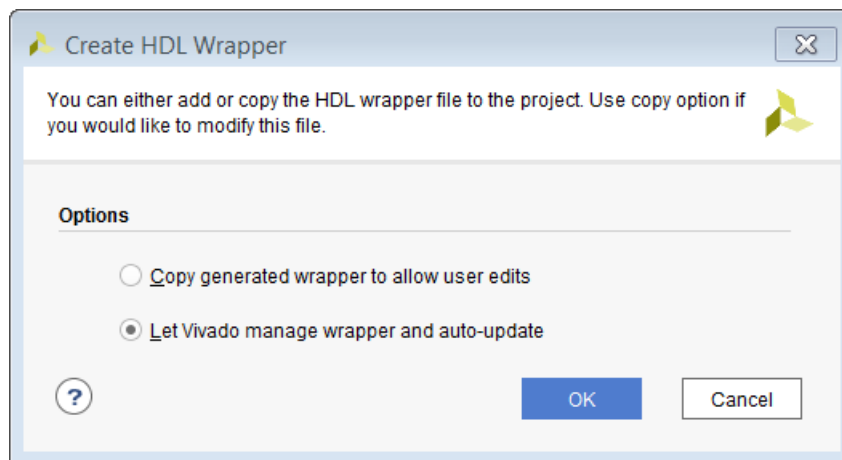

Figure 21: Create HDL Wrapper Dialog Box

7. Select the default option of **Let Vivado manage wrapper and auto-update**.
8. Click **OK**.

After the wrapper has been created, the Sources window looks as follows.

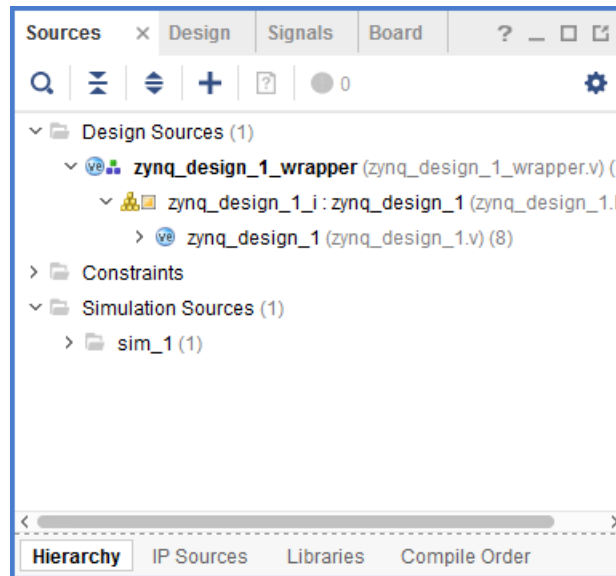

Figure 22: Source Window After Creating the Wrapper

Step 5: Implement Design and Generate Bitstream

1. In **Flow Navigator** > **Program and Debug**, click **Generate Bitstream** to implement the design and generate a BIT file.

The No Implementation Results Available dialog box opens.

2. Click **Yes**.
3. The Launch Runs dialog box opens. Here you can select various options such as the Number of Jobs, the host where the Runs are launched etc.
4. Click **OK**.

This will launch synthesis, implementation and generate the bitstream which could take a few minutes.

5. After the bitstream generates, the Bitstream Generation Completed dialog box opens, as shown in the following figure. **Open Implemented Design** should be checked by default.

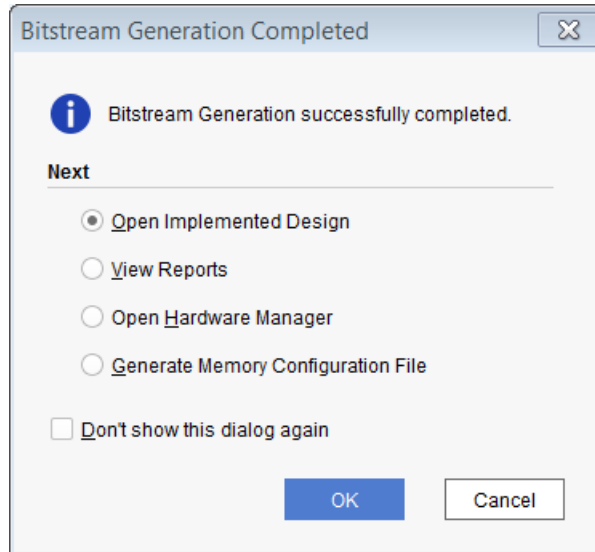

Figure 23: Bitstream Generation Completed

6. Click **OK**.
7. When the implemented design opens, look at the timing window to ensure that all timing constraints were met.

Step 6: Export Hardware to SDK

In this step, you export the hardware description to SDK.



IMPORTANT: For the Digilent driver to install, you must power on and connect the board to the host PC before launching SDK.

1. From the main Vivado File menu, select **File > Export > Export Hardware**.

The Export Hardware dialog box opens.

2. Ensure that the **Include Bitstream** check box is checked and that the **Export to field** is set to the default option of **<Local to Project>** as shown in the following figure:

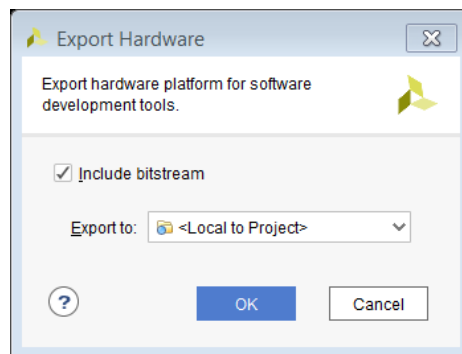

Figure 24: Export Hardware for SDK

3. Click **OK**.
4. To launch SDK, select **File > Launch SDK**.
The Launch SDK dialog box opens.
5. Accept the default selections for **Exported location** and **Workspace** and click **OK**.

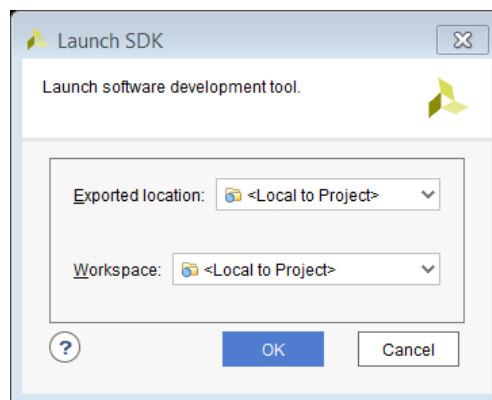

Figure 25: Launch SDK Dialog Box

Step 7: Create a Software Application

SDK launches in a separate window.

1. Select **File > New > Application Project**.

The New Project dialog box opens.

2. In the Project Name field, type the name desired, such as `Zynq_Design`.

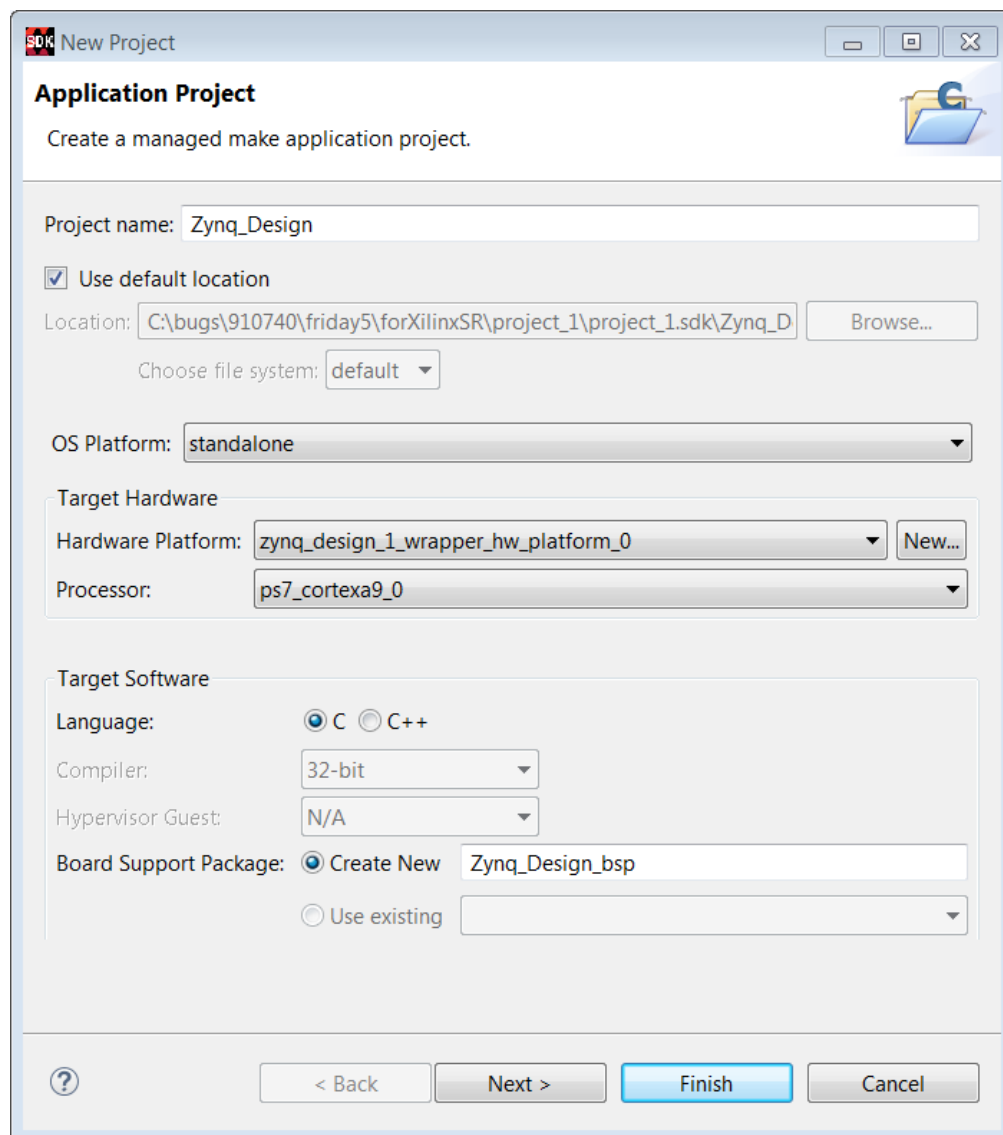

Figure 26: SDK Application Project

3. Click **Next**.

- From the Available Templates, select Peripheral Tests as shown in the following figure:

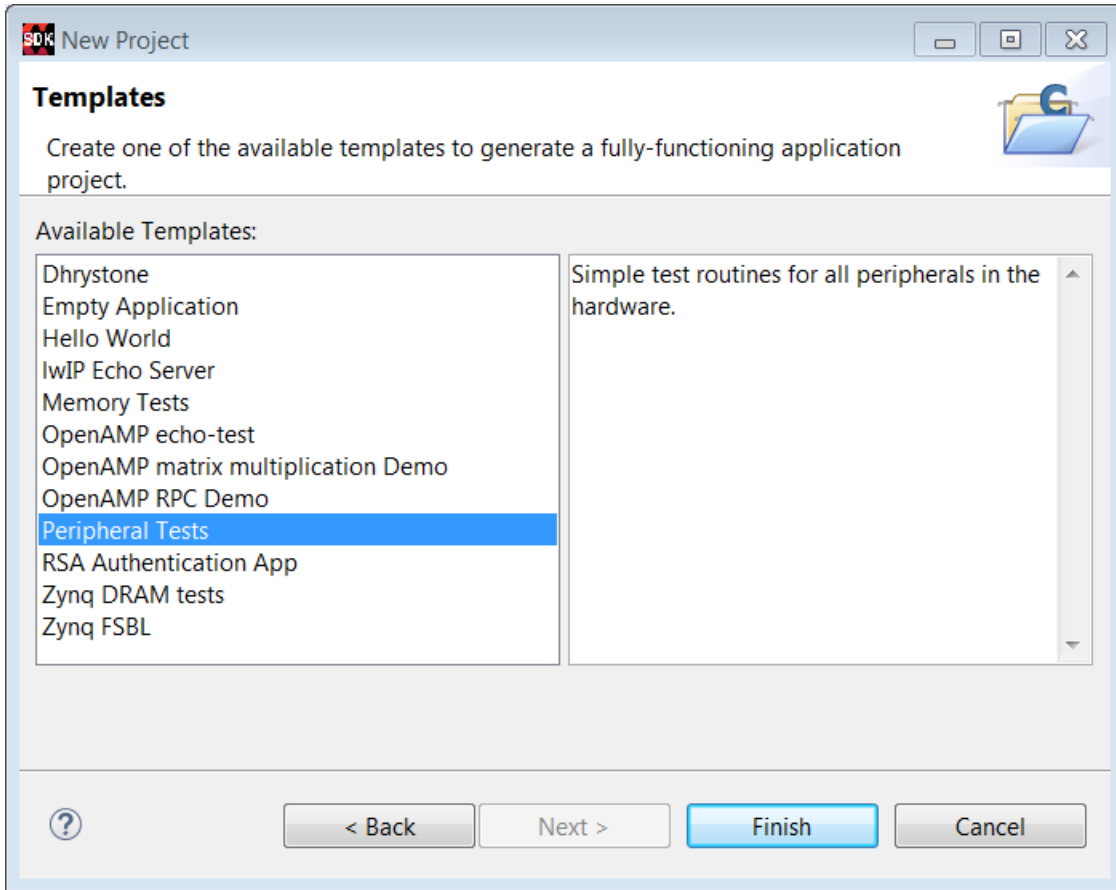

Figure 27: SDK New Project Template

- Click **Finish**.

When the program finishes compiling, you see the following in the Console window.

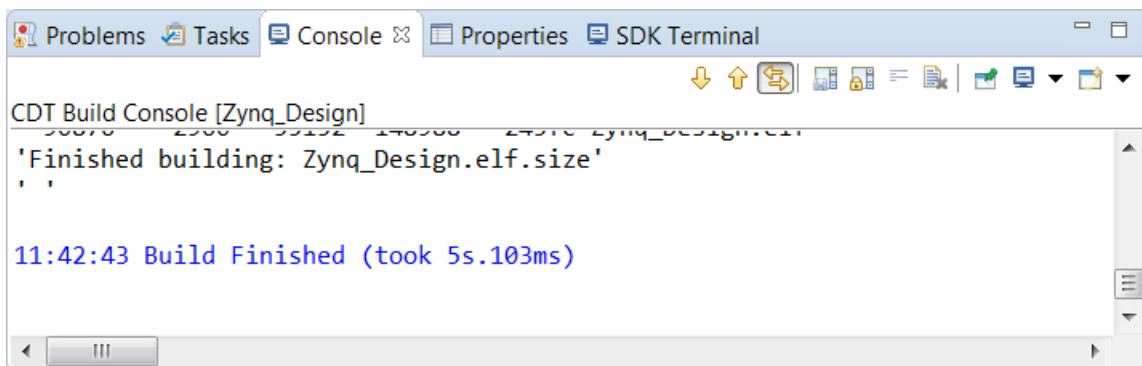

Figure 28: SDK Message

Step 8: Run the Software Application

Now, run the peripheral test application on the ZC702 board. To do so, you need to configure the JTAG port.

1. Ensure that your hardware is powered on and a Digilent Cable or the USB Platform Cable is connected to the host PC. Also, ensure that you have a USB cable connected to the UART port of the ZC702 board.

2. Download the bitstream into the FPGA by selecting **Xilinx Tools > Program FPGA**.

The Program FPGA dialog box opens.

3. Ensure that the Bitstream field shows the bitstream file that you created in Step 5, and then click Program.

Note: The DONE LED on the board turns green if the programming is successful. You should also see an INFO message suggesting that the FPGA was configured successfully in the SDK Log window.

4. In the Project Explorer, select and right-click the **Zynq_Design** application.

5. Select **Debug As > Debug Configurations**.

6. In the Debug Configurations dialog box, right-click **Xilinx C/C++ application (System Debugger)** and select **New**.

7. In the Debug Configurations dialog box, click **Debug**, as shown in the following figure:

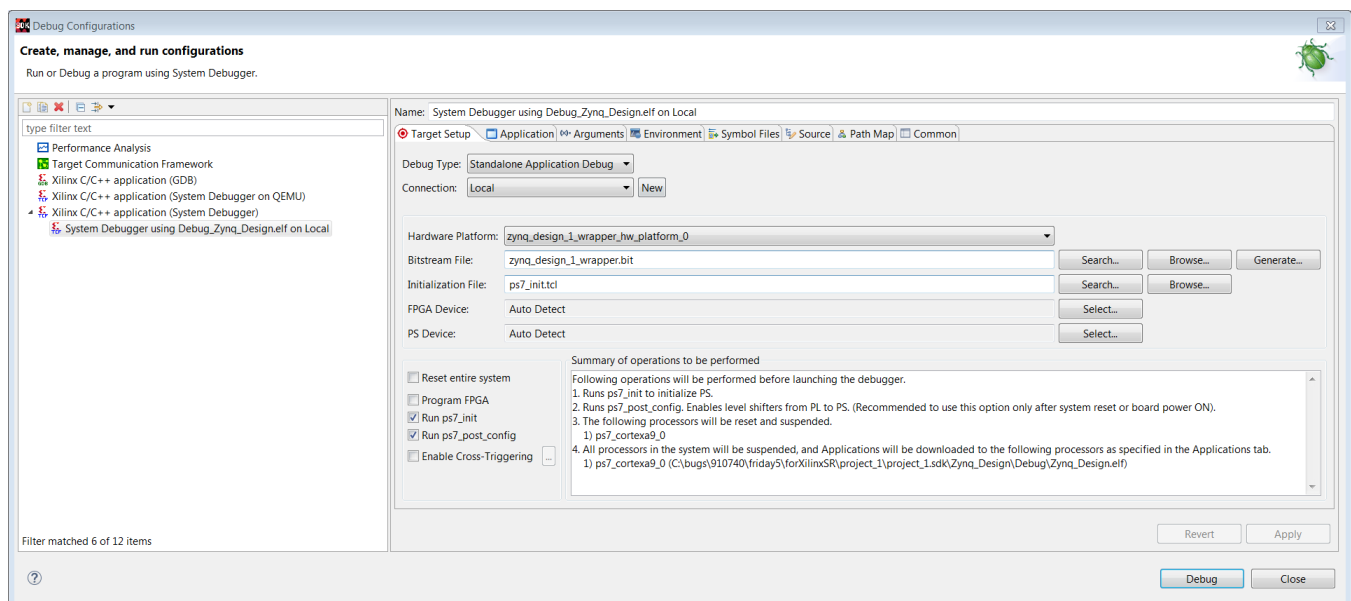



Figure 29: Run Debug Configurations

The Confirm Perspective Switch dialog box opens.

8. Click **Yes**.
9. Set the terminal by selecting the **SDK Terminal** tab and clicking the  icon.
10. Use the settings shown in the following figure, or the ZC702 board. The COM Port might be different on your machine.

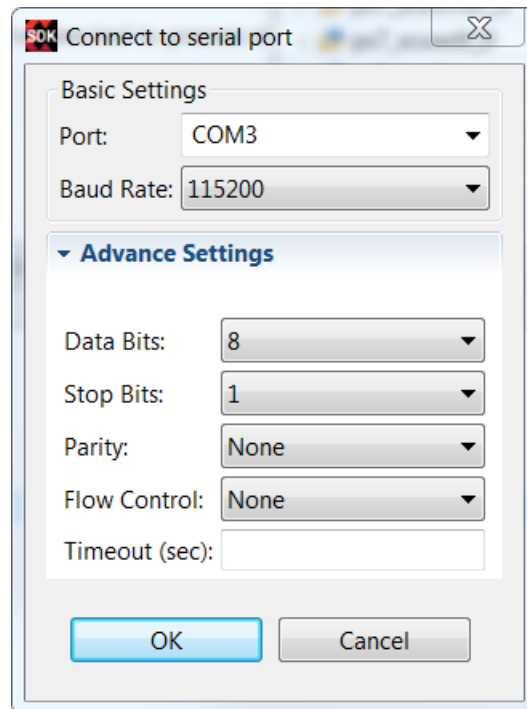

Figure 30: Terminal Settings for ZC702 Board

11. Click **OK**.
12. Verify the **Terminal** connection by checking the status at the top of the tab.

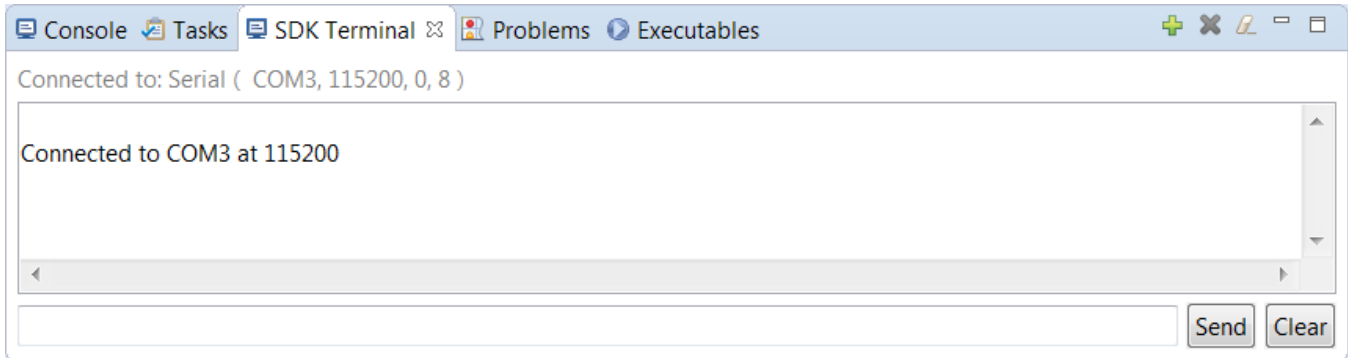

Figure 31: Terminal Connection Verification

13. In the Debug tab, expand the tree to see the processor core on which the program is running, as shown in the following figure:

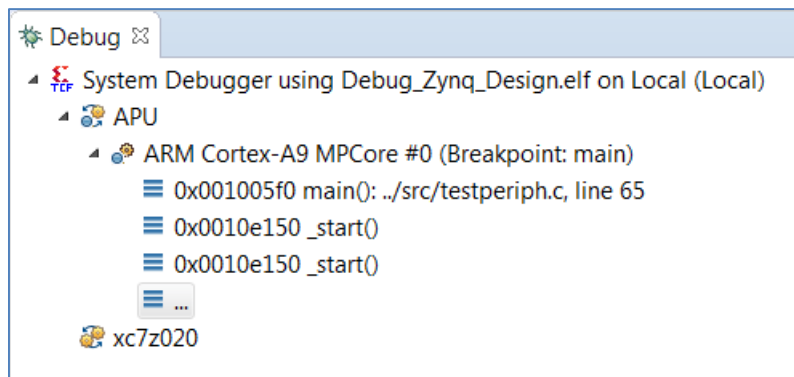

Figure 32: Processor Core to Debug

14. If `testperiph.c` is not already open, select `../src/testperiph.c`, double-click it to open that location

Add a Breakpoint

Next, add a breakpoint after the "if" statement.

1. From the main menu, select **Navigate > Go To Line**.
2. In the Go To Line dialog box, type **107** and click **OK**.

Note: Sometimes the line number varies, so enter the breakpoint where appropriate.



TIP: If line numbers are not visible, right-click in the blue bar on the left side of the window and select **Show Line Numbers**.

- Double-click in the blue bar to the left of line 107 to add a breakpoint on that line of source code, shown in the following figure:

```

97
98
99  {
100     u32 status;
101
102     print("\r\nRunning GpioOutputExample() for axi_gpio_0...\r\n");
103
104     status = GpioOutputExample(XPAR_AXI_GPIO_0_DEVICE_ID,4);
105
106     if (status == 0) {
107         print("GpioOutputExample PASSED.\r\n");
108     }
109     else {
110         print("GpioOutputExample FAILED.\r\n");
111     }
112 }

```

Figure 33: Add a Breakpoint

Note: Sometimes the line number varies, so enter the breakpoint where appropriate.

Step 9: Connect to the Vivado Logic Analyzer

- Connect to the ZC702 board using the Vivado® logic analyzer.
- Go back to the Vivado session and from the Program and Debug drop-down list in the **Flow Navigator > Program and Debug**, click **Open Hardware Manager**.
- In the Hardware Manager window, click **Open target** and select **Open New Target** to open a connection to the Digilent JTAG cable for ZC702, as shown below.

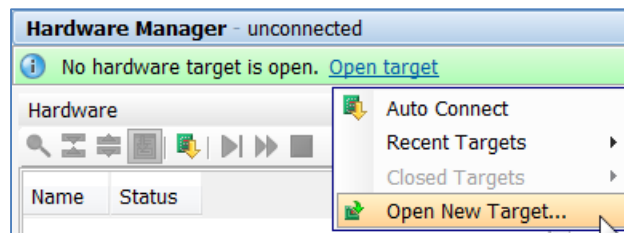

Figure 34: Launch Open New Hardware Target Wizard

The Open New Hardware Target dialog box opens.

- Click **Next**.

5. Select the appropriate options from the drop down menu for **Connect to** option. Click **Next** on the Hardware Server Settings page.
6. The hardware server should be able to identify the hardware target. Click **Next** on the Select Hardware Target page.
7. Click **Finish** in the **Open Hardware Target Summary** page.

When the Vivado hardware session successfully connects to the ZC702 board, the Hardware window shows the following information:

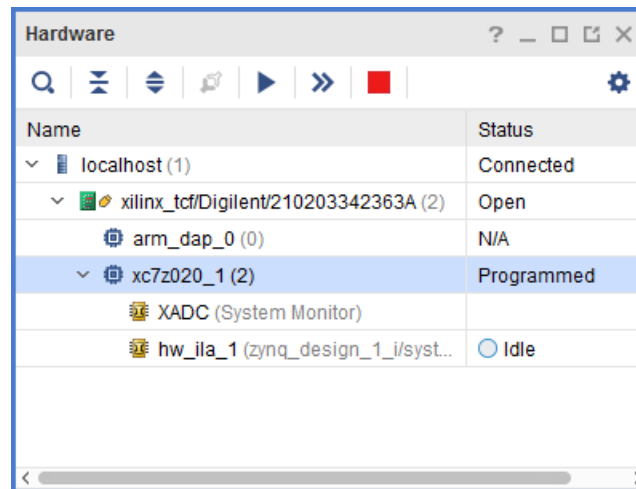



Figure 35: Successfully Programmed Hardware Session

8. First, ensure that the ILA core is active and capturing data. To do this, select the Status tab of the `hw_ila_1` in the Hardware Manager.
9. Click the **Run Trigger Immediate** button  on the `hw_ila_1` window.

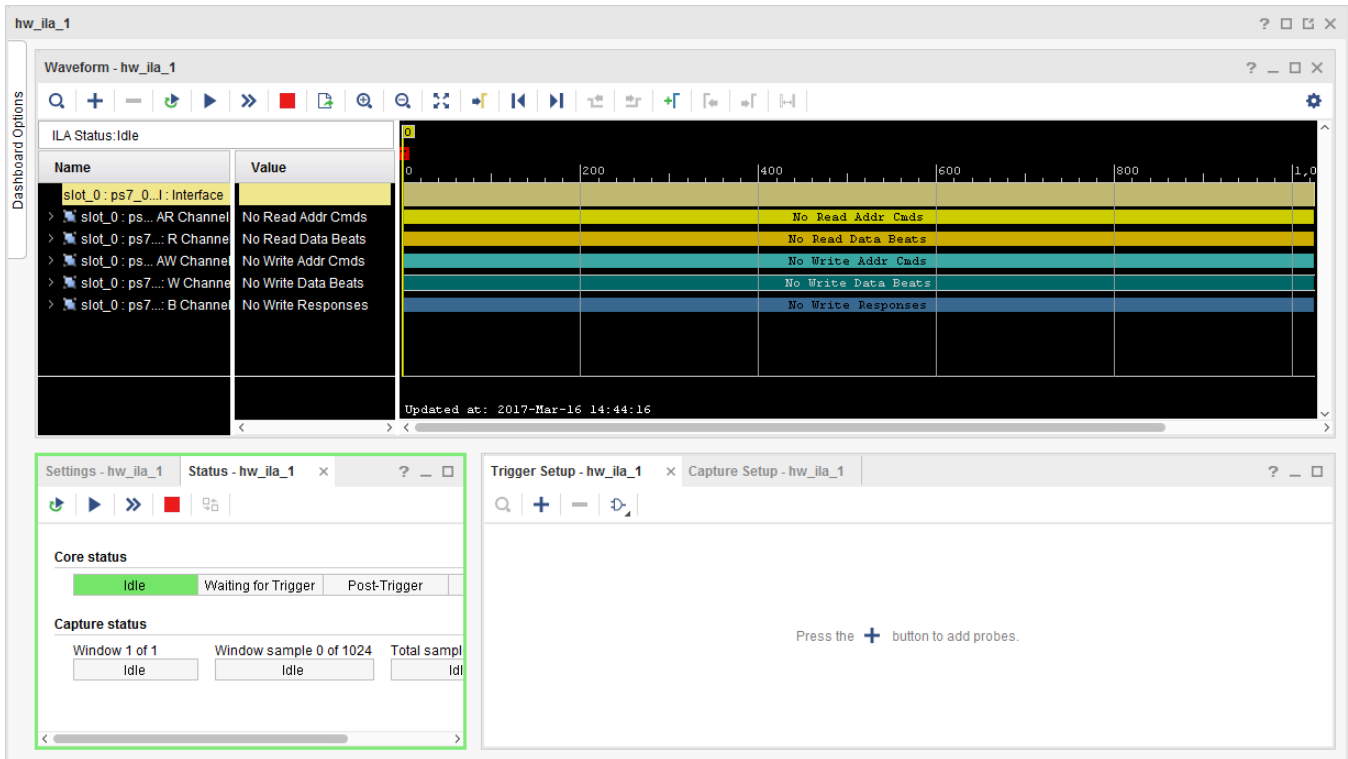

Figure 36: Run Trigger Immediate to capture static data

Expand some of the Signal Groups by clicking on the + sign to see Static data from the System ILA core in the waveform window as shown in the following figure.

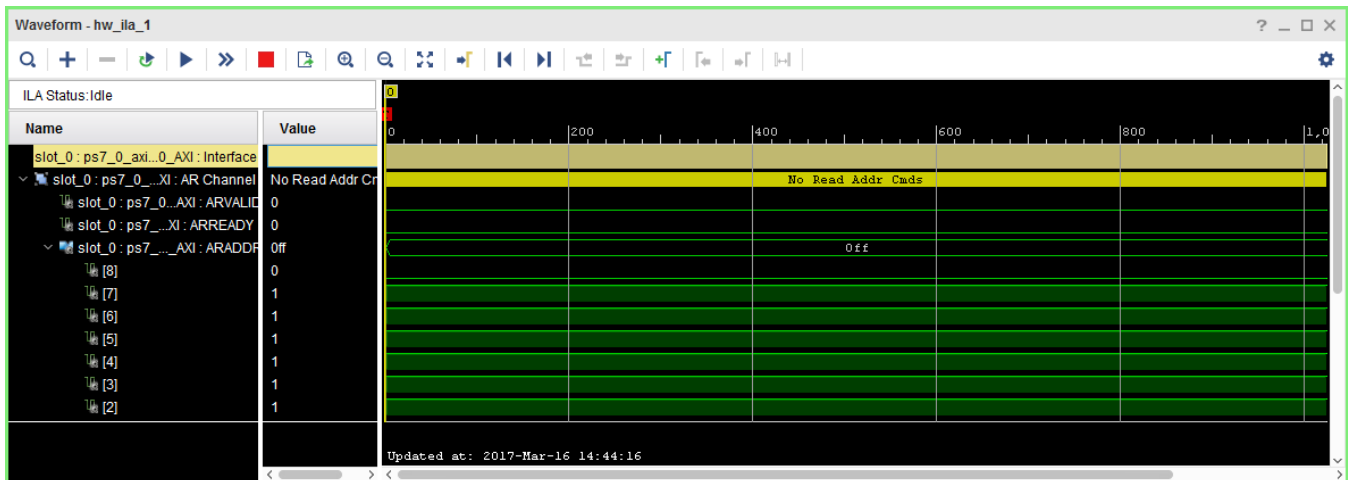

Figure 37: Static Data from the hardware

10. Set up a condition that triggers when the application code writes to the GPIO peripheral. To do this:
 - a. From the menu select **Window > Debug Probes**.
 - b. Select, drag and drop the `slot_0:ps7_0_axi_periph_M00_AXI:AWVALID` signal from the Debug Probes window into the Trigger Setup window.

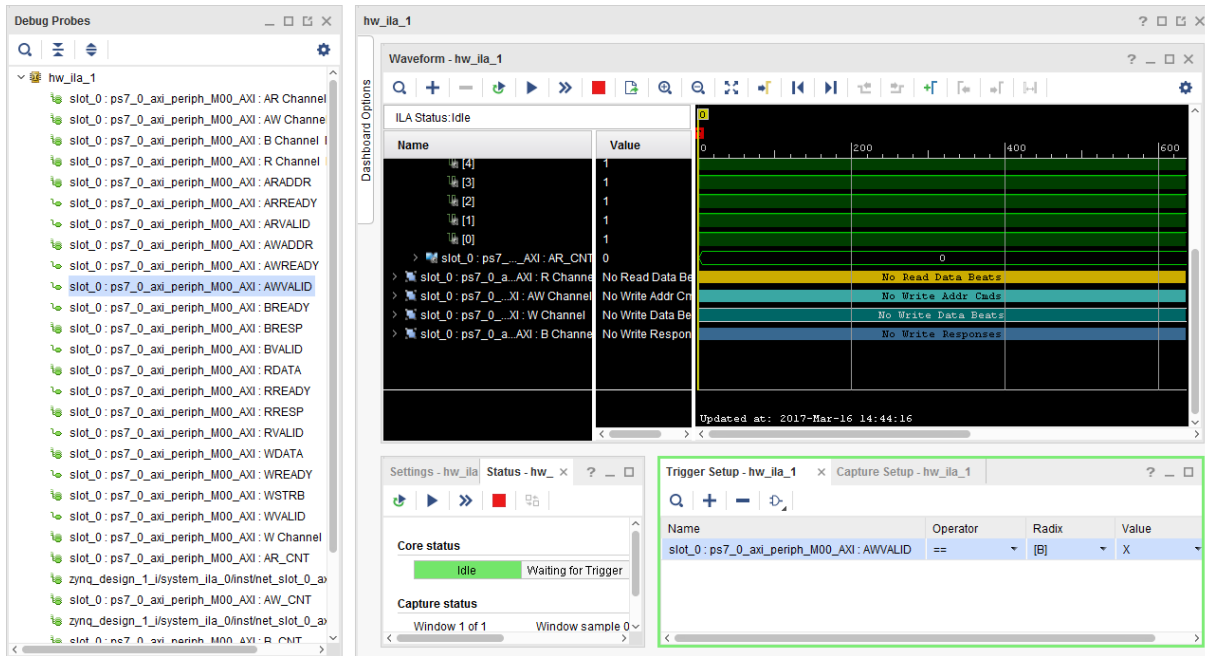

Figure 38: The ILA Properties window

- c. Click the **Value** column of the `*WVALID` row, as shown below.

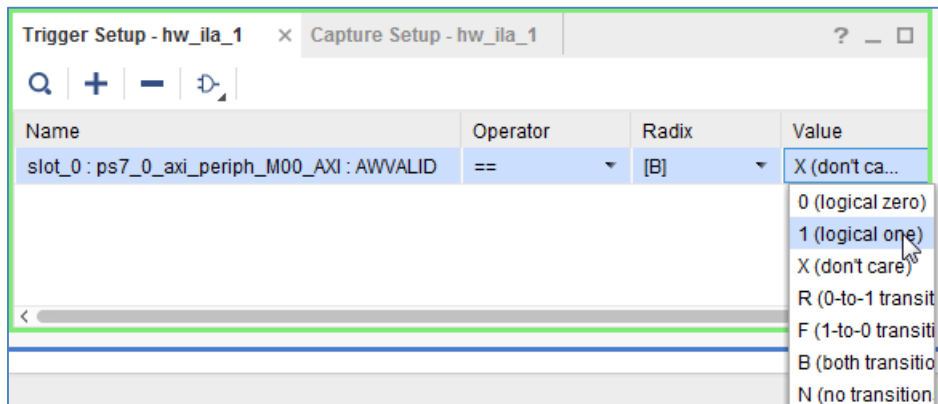

Figure 39: ILA Properties Window

- d. Change the value from an **X** to a **1**, from the drop down menu.

11. You also want to see several samples of the captured data before and after the trigger condition. Change the trigger position to the middle of the 1024 sample window by setting the **Trigger Position in window** for the hw_ila_1 core in the ILA Properties window to 512 and then pressing Enter, as shown below.

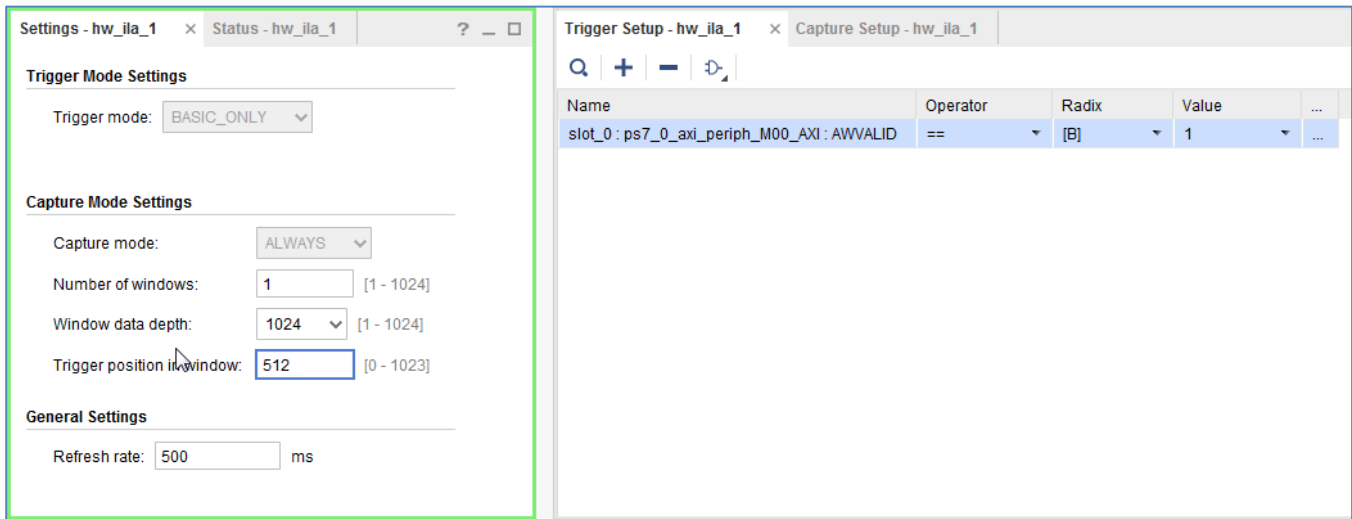

Figure 40: Change Capture Mode Settings

After setting up the compare value and the trigger position, you can arm the ILA core.

12. In the Waveform window or the Status window, arm the ILA core by clicking the **Run Trigger** button



13. Notice that the Status window of the `hw_ila_1` ILA core changes from:

- **Idle** to **Waiting for Trigger**.
- Likewise, the Hardware window shows the Core Status as **Waiting for Trigger**, as shown in the following figure.

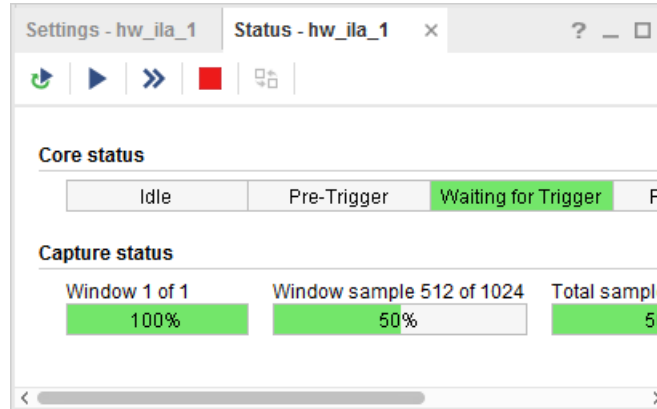



Figure 41: Status of hw_ila_1

14. Go back to SDK and continue to execute code. To do so, click the **Resume** button  on the SDK toolbar.

Alternatively, you can press **F8** to resume code execution.

The code execution stops at the breakpoint you set. By this time, at least one write operation has been done to the GPIO peripheral. These write operations cause the `AWVALID` signal to go from 0 to 1, thereby triggering the ILA core.

Note: The trigger mark occurs at the first occurrence of the `AWVALID` signal going to a 1, as shown in [Figure 42](#).

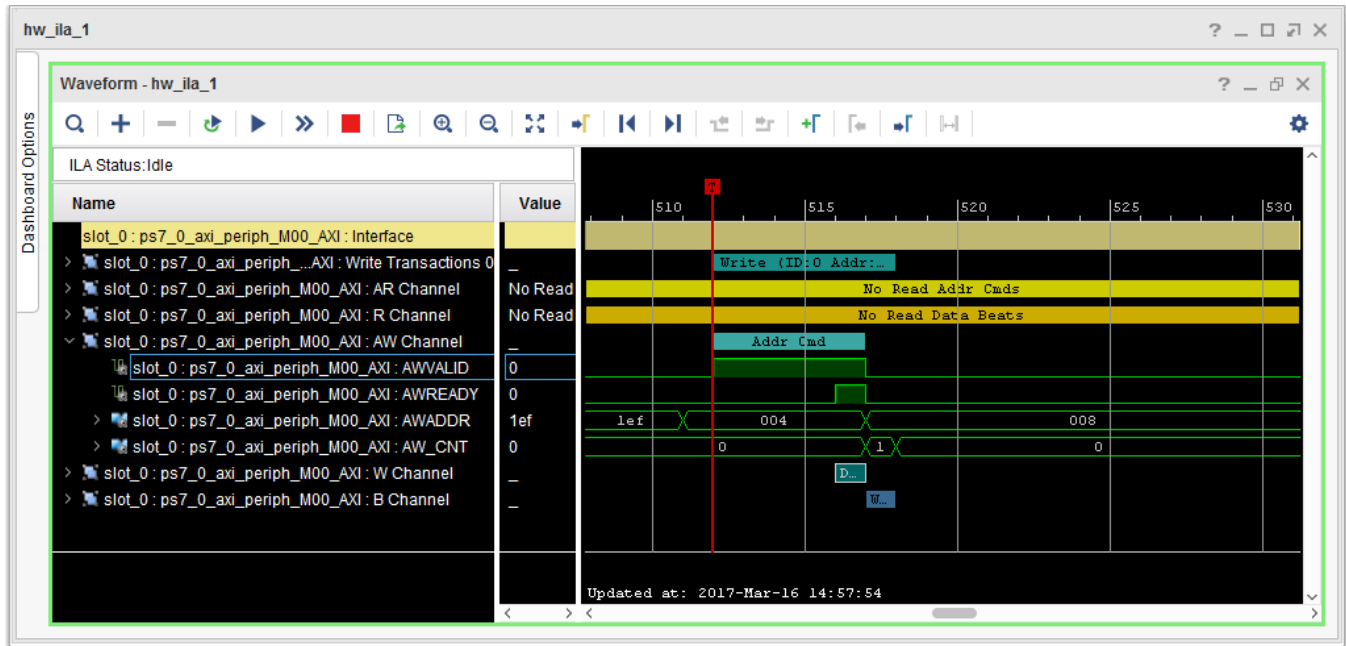

Figure 42: Trigger Mark Goes to 1

15. If you are going on to Lab 2, close your project by selecting **File > Close Project**.

You can also close the SDK window by selecting **File > Exit**.

Conclusion

This lab introduced you to creating a Zynq based design in IP Integrator, working with the System ILA IP to debug nets of interest, software development in SDK and executing the code on the Zynq-7000 AP SoC processor.

This lab also introduced you to the Vivado Logic Analyzer and analyzing the nets that were marked for debug and cross-probing between hardware and software.

In this lab, you:

- Created a Vivado project that includes a Zynq-7000 AP SoC processor design using the IP Integrator tool.
- Instantiated IP in the IP Integrator tool and made the necessary connections utilizing the Designer Assistance feature.
- Marked and connected nets for debug using the System ILA IP, to analyze them in the Vivado Integrated Logic Analyzer.
- Synthesized, implemented, and generated the bitstream before exporting the hardware definition to SDK.
- Created a software application in SDK and ran it on the target hardware, ZC702. By setting breakpoint in the application code, triggered the ILA in Vivado, thereby, demonstrating the hardware/software cross-probing ability.

Lab Files

You can use the Tcl file `lab1.tcl` that is included with this tutorial design files to perform all the steps in this lab. This Tcl file only covers the Vivado portion of the design creation through bitstream generation. Subsequent steps from Step 7 and beyond must be performed manually as the intent is to demonstrate the cross-probing between hardware and software.

To use the Tcl script, launch Vivado and type `source lab1.tcl` in the Tcl console.

Alternatively, you can also run the script in the batch mode by typing `Vivado -mode batch -source lab1.tcl` at the command prompt.

Note: You must modify the project path in the `lab1.tcl` file to source the Tcl files correctly.

Lab 2: Zynq-7000 AP SoC Cross-Trigger Design

Introduction

In this lab, you use the cross-trigger functionality between the Zynq®-7000 AP SoC processor and the fabric logic. Cross-triggering is a powerful feature that you can use to simultaneously debug software in the SDK that is running in real time on the target hardware. This tutorial guides you from design creation in IP integrator, to marking the nets for debug and manipulating the design to stitch up the cross-trigger functionality.

Step 1: Start the Vivado IDE and Create a Project

1. Start the Vivado® IDE by clicking the Vivado desktop icon or by typing `vivado` at a command prompt.
2. From the Quick Start page, select **Create New Project**.
3. In the New Project dialog box, use the following settings:
 - a. In the **Project Name** dialog box, type the project name and location.
 - b. Make sure that the **Create project subdirectory** check box is checked. Click **Next**.
 - c. In the **Project Type** dialog box, select **RTL project**. Click **Next**.
 - d. In the **Add Sources** dialog box, set the **Target language** to either **VHDL** or Verilog. You can leave the Simulator language selection to **Mixed**. Click **Next**.
 - e. In **Add Constraints** dialog box, click **Next**.
 - f. In the **Default Part** dialog box, select **Boards** and choose **ZYNQ-7 ZC702 Evaluation Board** that matches the version of hardware that you have. Click **Next**.
 - g. Review the project summary in the **New Project Summary** dialog box before clicking **Finish** to create the project.

Step 2: Create an IP Integrator Design

1. In Vivado Flow Navigator, click **Create Block Design**.
2. In the **Create Block Design** dialog box, specify `zynq_processor_system` as the name of the block design.
3. Leave the Directory field set to its default value of **<Local to Project>** and the Specify source set field to **Design Sources**.
4. Click **OK**.

The IP integrator diagram window opens.

5. Click the **Add IP** icon in the block design canvas, as shown in the following figure.

This design is empty. Press the  button to add IP.

Figure 43: Add IP to the Design

The IP catalog opens.

6. In the Search field, type `zynq`, select the **ZYNQ7 Processing System** IP, and press **Enter**.
Alternatively, double-click the **ZYNQ7 Processing System** IP to instantiate it as shown in the following figure.

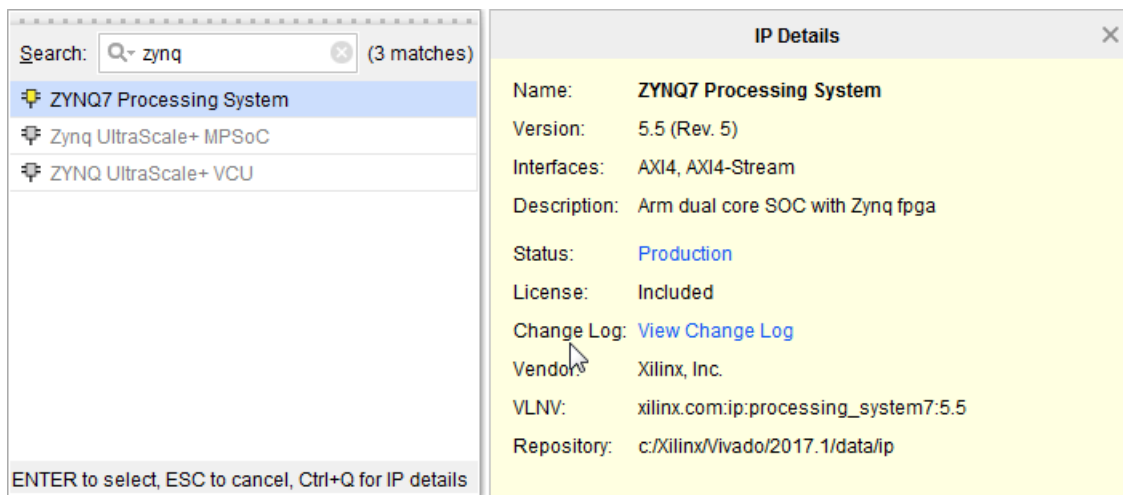

Figure 44: Instantiate the ZYNQ7 Processing System

- In the block design banner, click **Run Block Automation** as shown in the following figure.

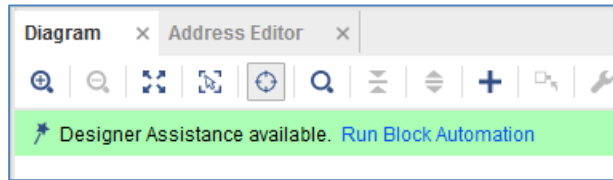

Figure 45: Run Block Automation on Zynq Processing System

The Run Block Automation dialog box states that the `FIXED_IO` and the `DDR` pins on the ZYNQ7 Processing System 7 IP will be connected to external interface ports. Also, because you chose the ZC702 board as your target board, the **Apply Board Preset** checkbox is checked by default.

- Enable the Cross Trigger In and Cross Trigger Out functionality by setting those fields to **Enable**, then click **OK**, as shown in the following figure:

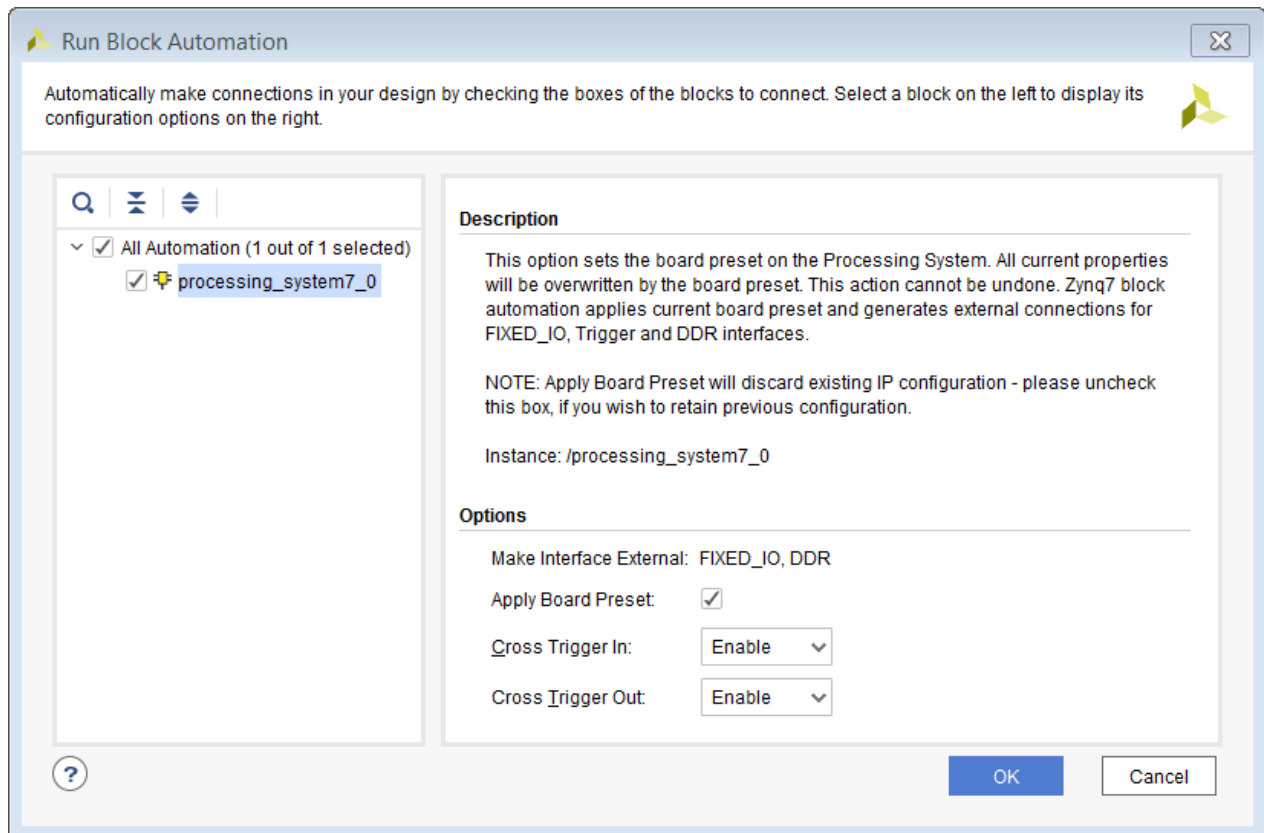

Figure 46: Run Block Automation Dialog Box

This enables the TRIGGER_IN_0 and TRIGGER_OUT_0 interfaces in the ZYNQ7 Processing System as show in the following figure.

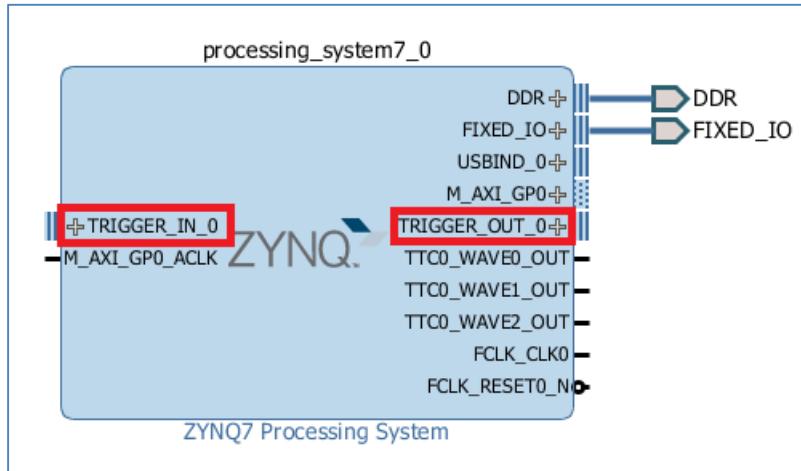

Figure 47: IP Integrator Canvas After Running Block Automation

9. Add the AXI GPIO and AXI BRAM Controller to the design by right-clicking anywhere in the diagram and selecting **Add IP**.

The diagram area looks like the following figure:

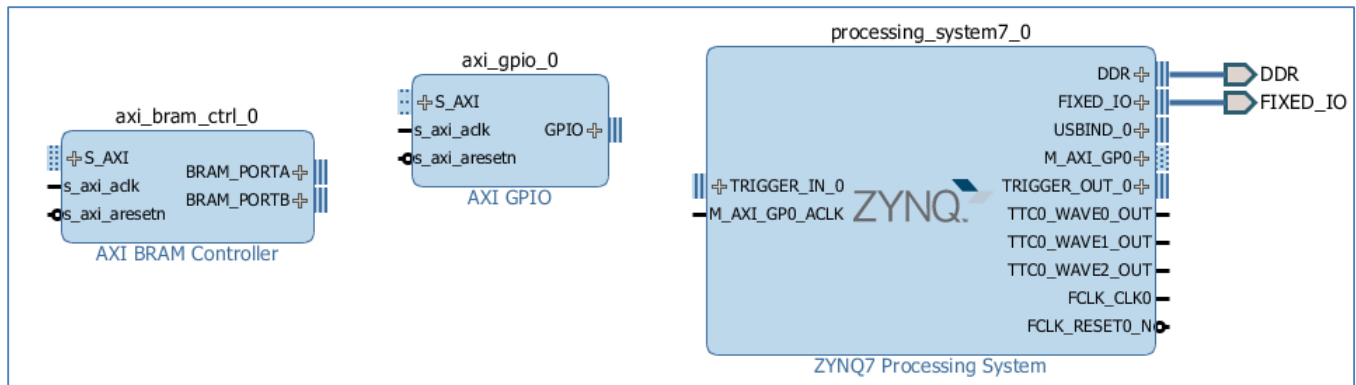

Figure 48: Diagram after Instantiating IP for This Design

10. Click the **Run Connection Automation** link at the top of the Diagram window.

The Run Connection Automation dialog box opens.

11. Select the **All Automation** (7 out of 7 selected) checkbox. This selects connection automation for all the interfaces in the design. Select each automation to see the available options for that automation in the right pane.

12. Make each of the following connections using the **Run Connection Automation** function.

Connection	More Information	Setting
axi_bram_ctrl_0 <ul style="list-style-type: none"> BRAM_PORTA 	The Run Connection Automation dialog box informs you that a new Block Memory Generator IP will be instantiated and connected to the AXI BRAM Controller PORTA.	No options.
axi_bram_ctrl_0 <ul style="list-style-type: none"> BRAM_PORTB 	Note that the Run Connection Automation dialog box offers two choices now. The first one is to use the existing Block Memory Generator from the previous step or you can chose to instantiate a new Block Memory Generator if desired. In this case, use the existing BMG.	Leave the Blk_Mem_Gen field set to its default value of Blk_Mem_Gen of BRAM_PORTA .
axi_bram_ctrl_0 <ul style="list-style-type: none"> S_AXI 	The Run Connection Automation dialog box states that the S_AXI port of the AXI BRAM Controller will be connected to the M_AXI_GP0 port of the ZYNQ7 Processing System IP. The AXI BRAM Controller needs to be connected to a Block Memory Generator block. The connection automation feature offers this automation by instantiating the Block Memory Generator IP and making appropriate connections to the AXI BRAM Controller.	Leave the Clock Connection (for unconnected clks) field set to Auto .
axi_gpio_0 <ul style="list-style-type: none"> GPIO 	The Run Connection Automation dialog box shows the interfaces that are available on the ZC702 board to connect to the GPIO.	Select LEDs_4Bits .
axi_gpio_0 <ul style="list-style-type: none"> S_AXI 	The Run Connection Automation dialog box states that the S_AXI pin of the GPIO IP will be connected to the M_AXI_GP0 pin of the ZYNQ7 Processing System. It also offers a choice for different clock sources that might be relevant to the design.	Leave the Clock Connection (for unconnected clks) field set to Auto .
processing_system7_0 <ul style="list-style-type: none"> TRIGGER_IN_0 TRIGGER_OUT_0 	The Run Connection Automation dialog box states that the TRIGGER_IN_0 and TRIGGER_OUT_0 pins will be connected to the respective cross-trigger pins on the System ILA IP.	Leave the ILA option to its default value of Auto for both TRIGGER_IN_0 and TRIGGER_OUT_0 option.

When these connections are complete, the IP integrator design looks like the following figure:

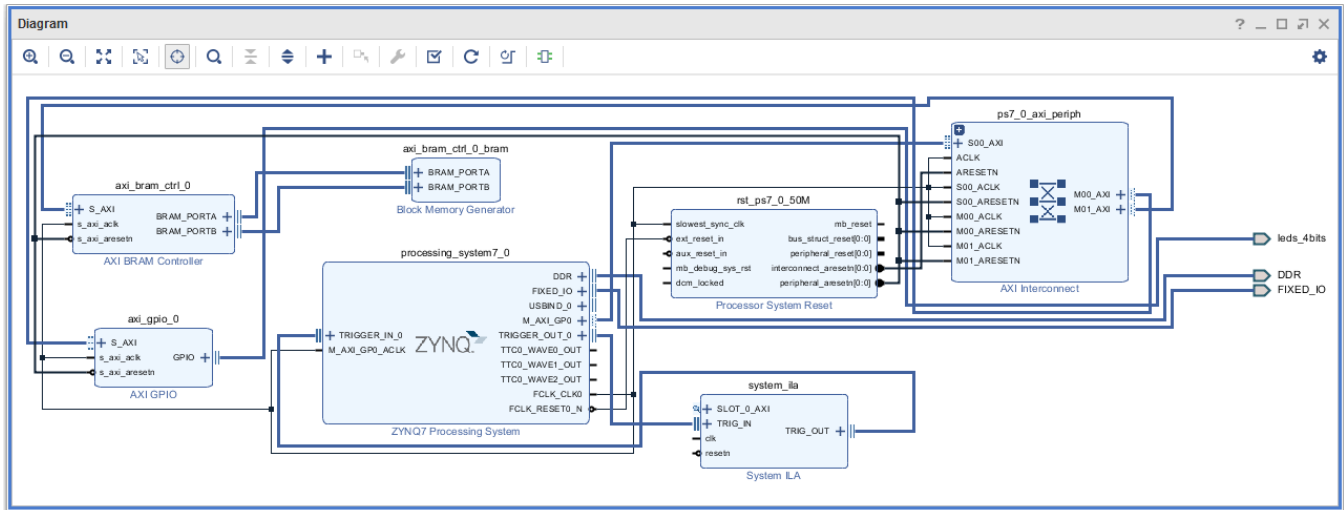

Figure 49: Design after Running Connection Automation

- Click the **Address Editor** tab of the design to ensure that addresses for the memory-mapped slaves have been assigned properly. Expand **Data**. Change the range of the AXI BRAM Controller to **64K**, as shown below.

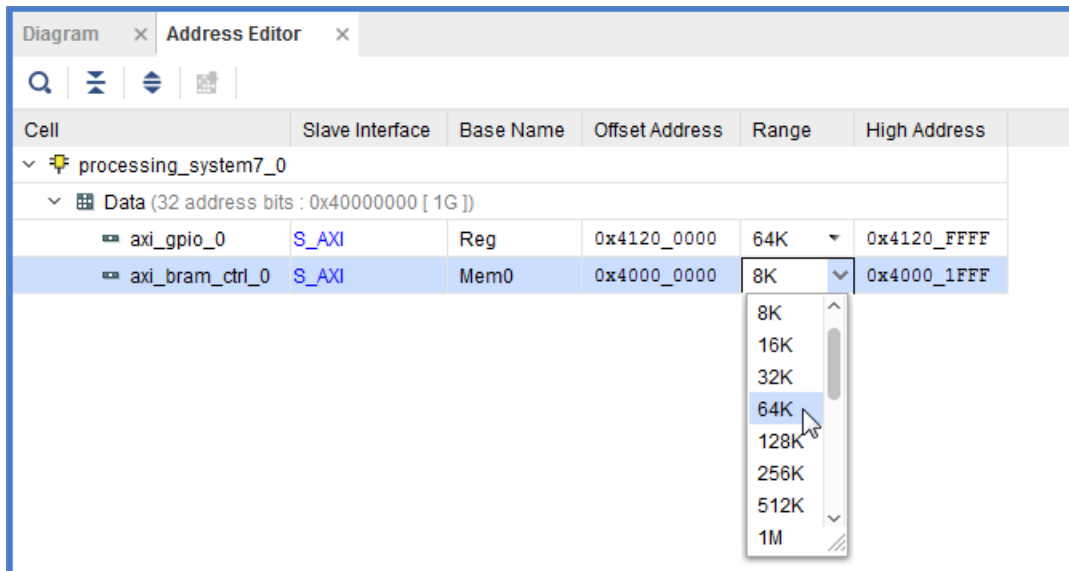

Figure 50: Memory Map the Slaves

Mark Nets for Debugging

Next, you mark some nets for debugging.

1. Click the **Diagram** tab again and select the net connecting the gpio pin of the AXI GPIO IP to the LEDs_4Bits port.
2. Right-click in the block diagram area and select **Debug**. This marks the net for debug.
3. Notice that a bug symbol appears on the net to be debugged. You can also see this bug symbol in the Design Hierarchy window on the selected net.
4. Similarly, select the net connecting the interface pin S_AXI of axi_gpio_0 and the M00_AXI interface pin of ps7_0_axi_periph.
5. Right-click in the block design and select **Debug** from the context menu.
6. Note that when you mark a net for debugging the Designer Assistance link at the top of the block design canvas banner becomes active. Click on **Run Connection Automation**.
7. In the Run Connection Automation dialog box, click the checkbox **All Automation (2 out of 2 selected)**.

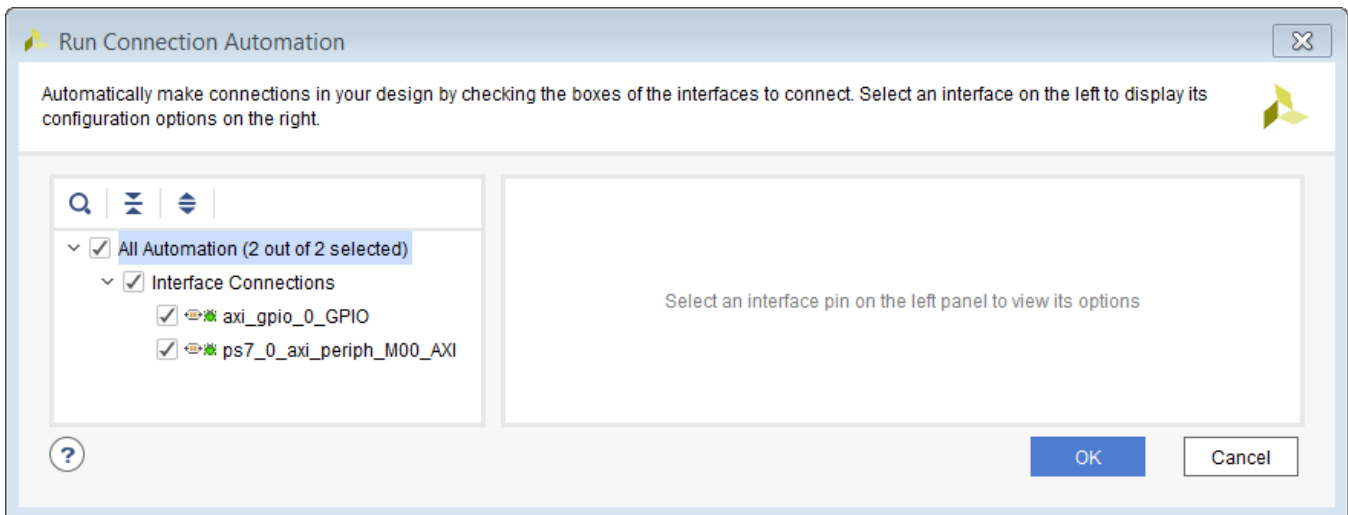



Figure 51: Run Connection Automation Dialog Box for Connecting Nets to be Debugged to System ILA

8. Click **OK**.

- Click the **Regenerate Layout** button  to generate an optimal layout of the design. The design should look like the following figure:

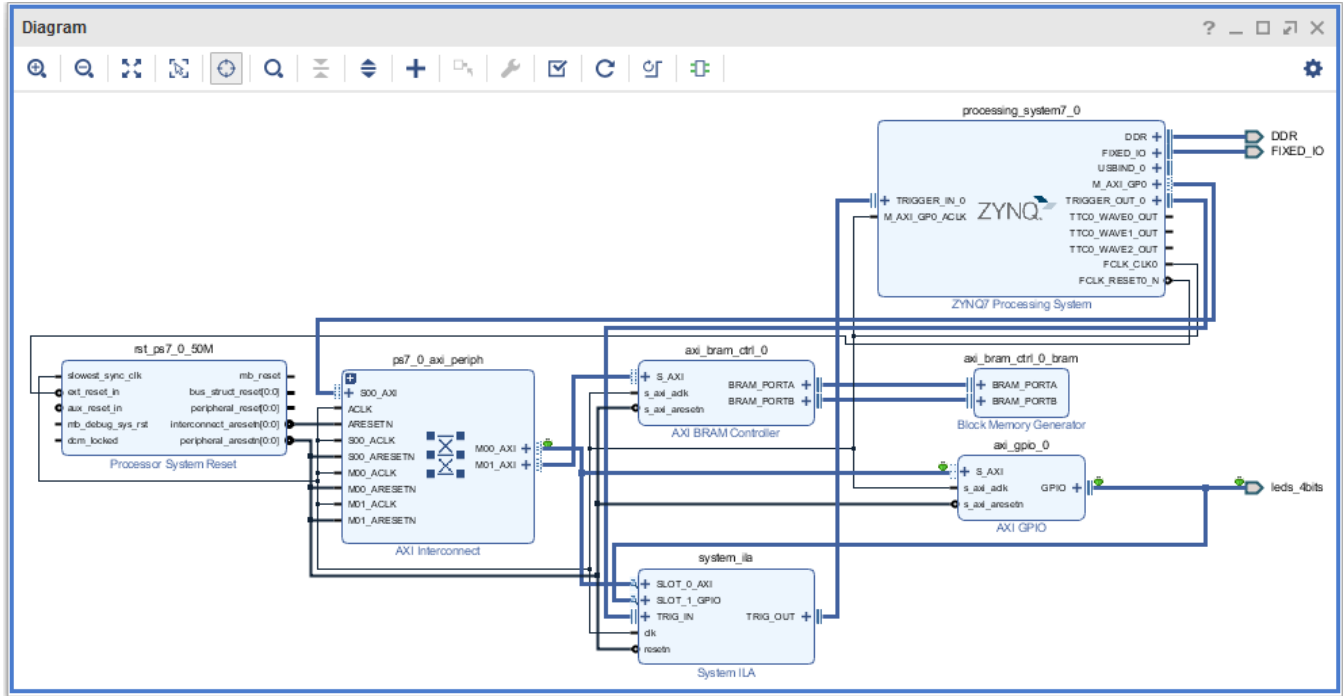

Figure 52: Block Design after Running Regenerate Layout

- Click the **Validate Design** button to run Design Rule Checks on the design.

After design validation is complete, the **Validate Design** dialog box opens to verify that there are no errors or critical warnings in the design.

- Click **OK**.

- Select **File > Save Block Design** to save the IP integrator design.

Alternatively, press **Ctrl + S** to save the design.

- In the Sources window, right-click the block design, `zynq_processor_system`, and **select Generate Output Products**.

The Generate Output Products dialog box opens.

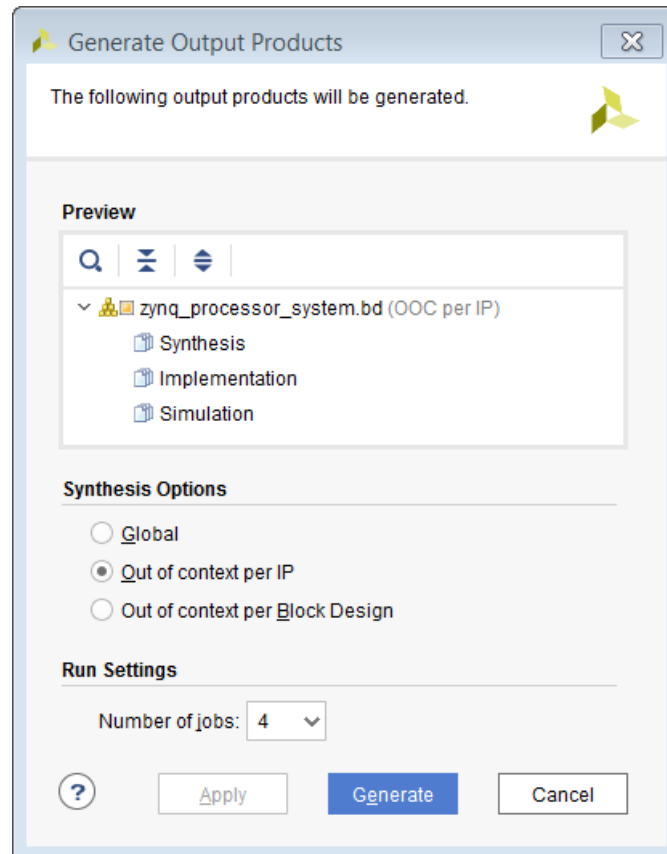

Figure 53: Generate Output Products Dialog Box

14. Click **Generate**.
15. The Generate Output Products dialog box informs you that out-of-context (OOC) module runs were launched. Click **OK** on the Generate Output Products dialog box.
16. Wait until all OOC Module runs have finished running. This could take a few minutes.

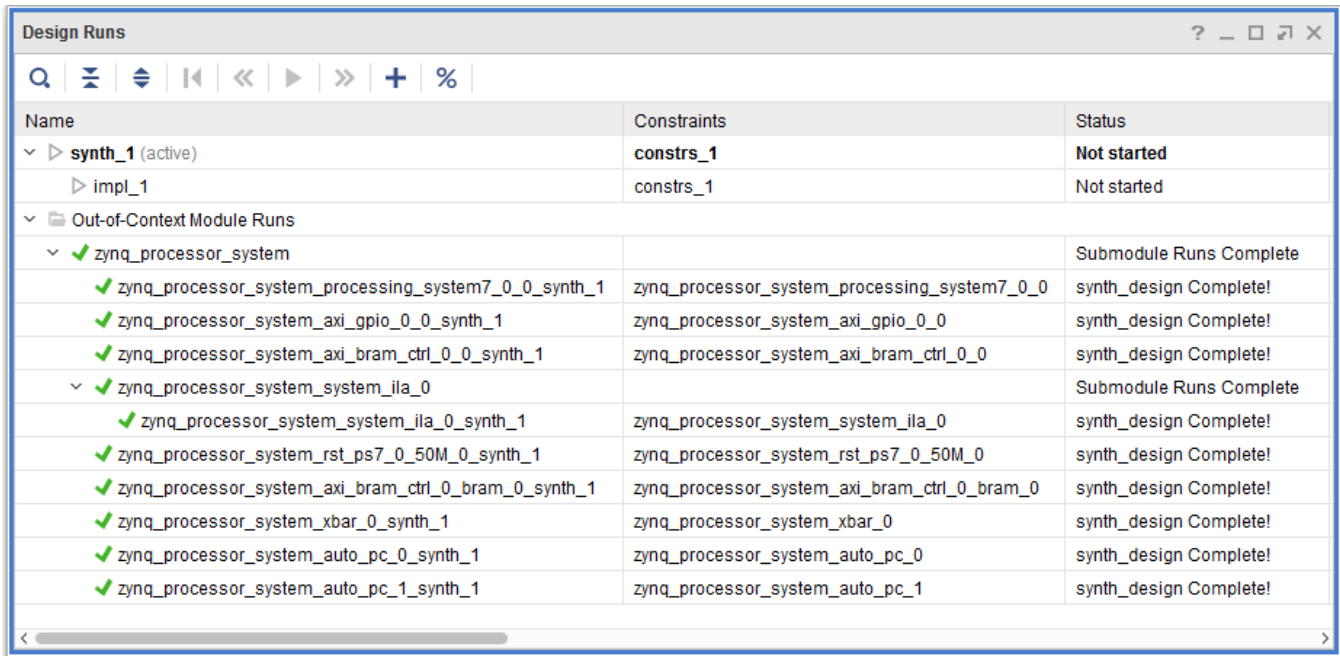

Figure 54: Design Runs window showing the status of Out-of-Context Module Runs

17. In the Sources window, right-click `zynq_processor_system`, and select **Create HDL Wrapper**.

The Create HDL Wrapper dialog box offers two choices:

- The first choice is to generate a wrapper file that you can edit.
- The second choice is let Vivado generate and manage the wrapper file, meaning it is a read-only file.

18. Keep the default setting, shown in the following figure, and click **OK**.

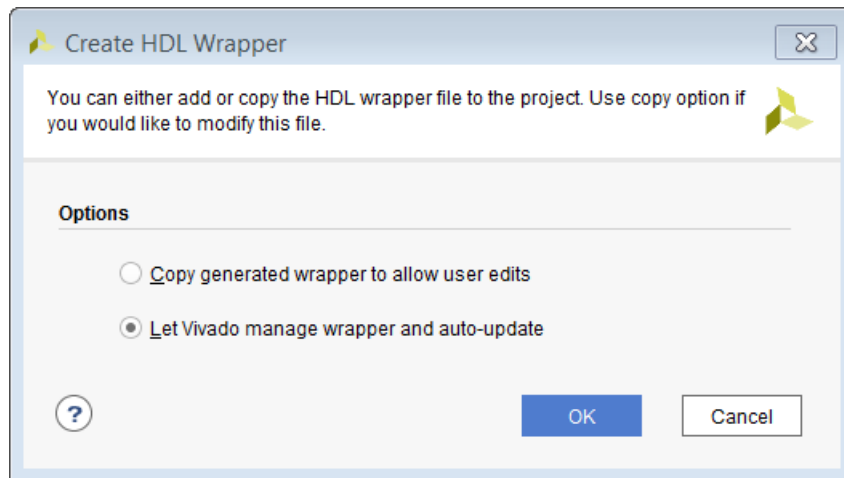

Figure 55: Create HDL Wrapper Dialog Box

Step 3: Implement Design and Generate Bitstream

Now that the cross-trigger signals have been connected to the ILA for monitoring, you can complete the rest of the flow.

1. Click **Generate Bitstream** to generate the bitstream for the design. The **No Implementation Results Available** dialog box opens with a message asking whether its okay to launch synthesis and implementation.
2. Click **Yes**.
3. The **Launch Runs** dialog box opens. Make the appropriate selections and click **OK**.

When bitstream generation completes, the **Bitstream Generation Completed** dialog box opens, with the option **Open Implemented Design** option checked by default.

4. Click **OK** to open the implemented design.
5. Ensure that all timing constraints are met by looking at the Timing Summary tab, as shown in the following figure. Note that timing could be slightly different in your case.



Figure 56: Timing Summary

Step 4: Export Hardware to SDK

After you generate the bitstream, you must export the hardware to SDK and generate your software application.

1. Select **File > Export > Export Hardware**.
2. In the Export Hardware for SDK dialog box, make sure that the **Include bitstream** check box is checked, and **Export to field** is set to **<Local to Project>**, as shown in the following figure.

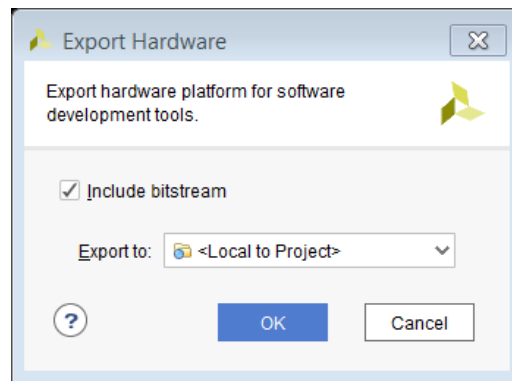

Figure 57: Export Hardware for SDK Dialog Box

3. Click **OK**.
4. Select **File > Launch SDK**. Make sure that both the **Exported location** and **Workspace** fields are set to **<Local to Project>**, as shown below in the following figure:

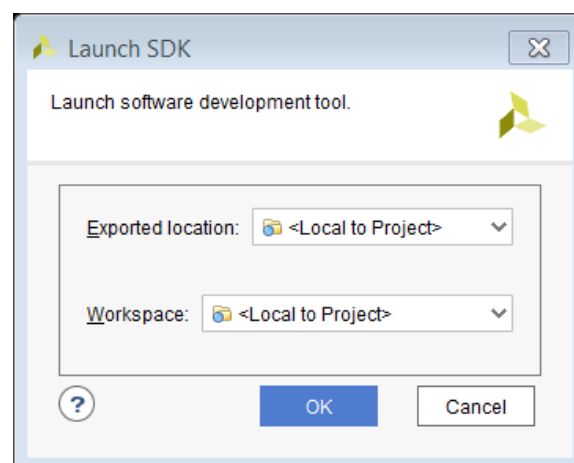

Figure 58: Launch SDK Dialog Box

5. Click **OK**.

Step 5: Build Application Code in SDK

SDK launches in a separate window.

1. After the project has been loaded, select **File > New > Application Project**.

In the New Project dialog box, as it appears in the following figure, specify the name for your project. For this lab, you can use the name **peri_test**.

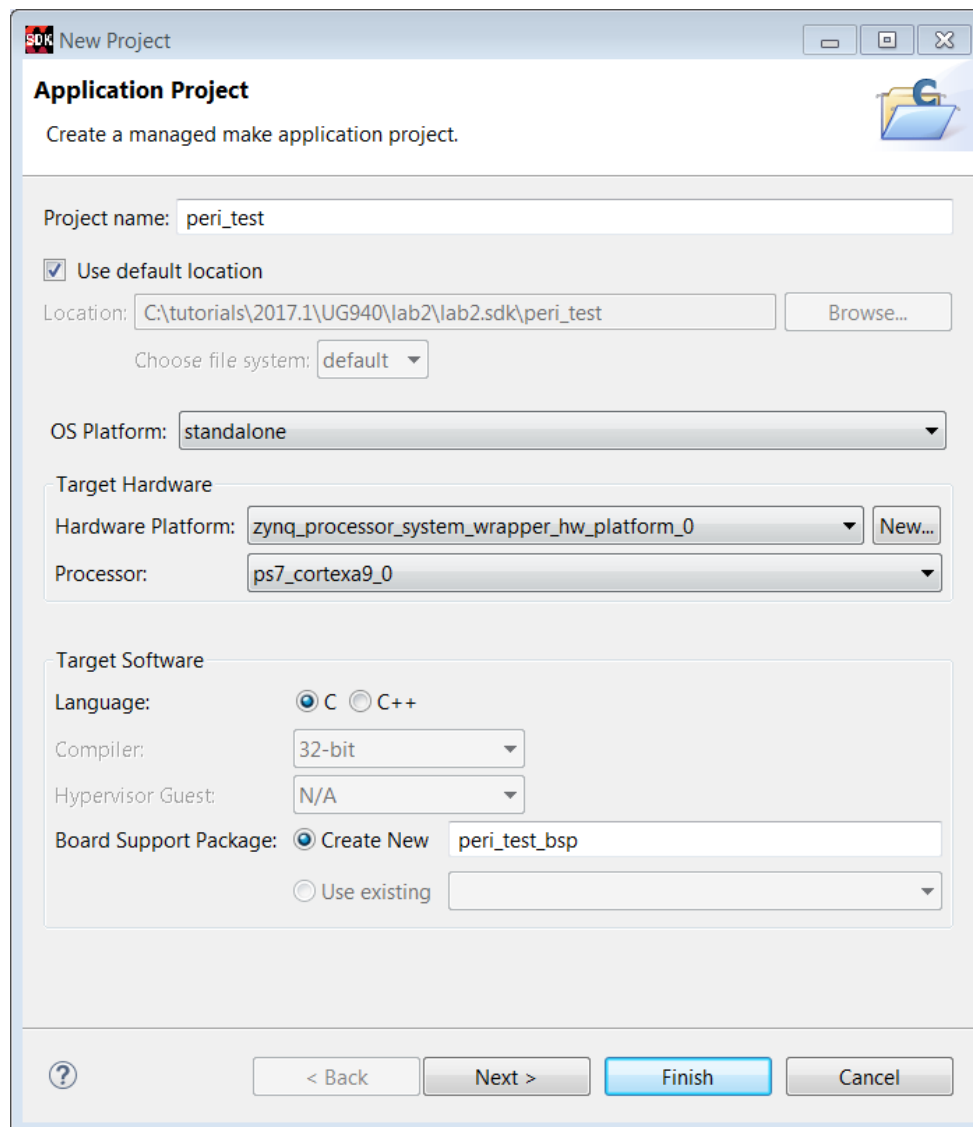

Figure 59: Name the Application Project

2. Click **Next**.

- From the Available Templates, select **Peripheral Tests**.

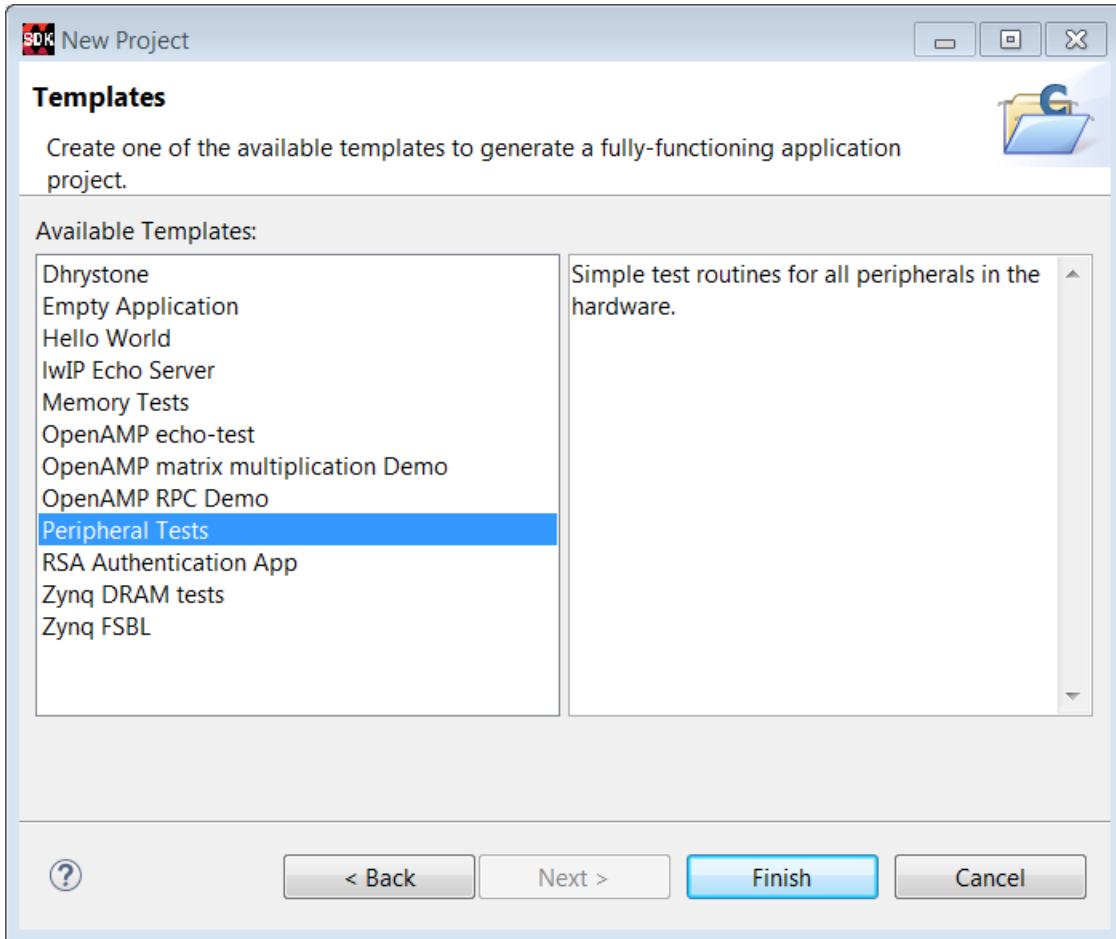

Figure 60: Select the Peripheral Tests Template

- Click **Finish**.
- Wait for the application to compile.
- Make sure that you have connected the target board to the host computer and it is turned on.
- After the application has finished compiling, select **Xilinx Tools > Program FPGA** to open the Program FPGA dialog box.

- In the Program FPGA dialog box, click **Program**.

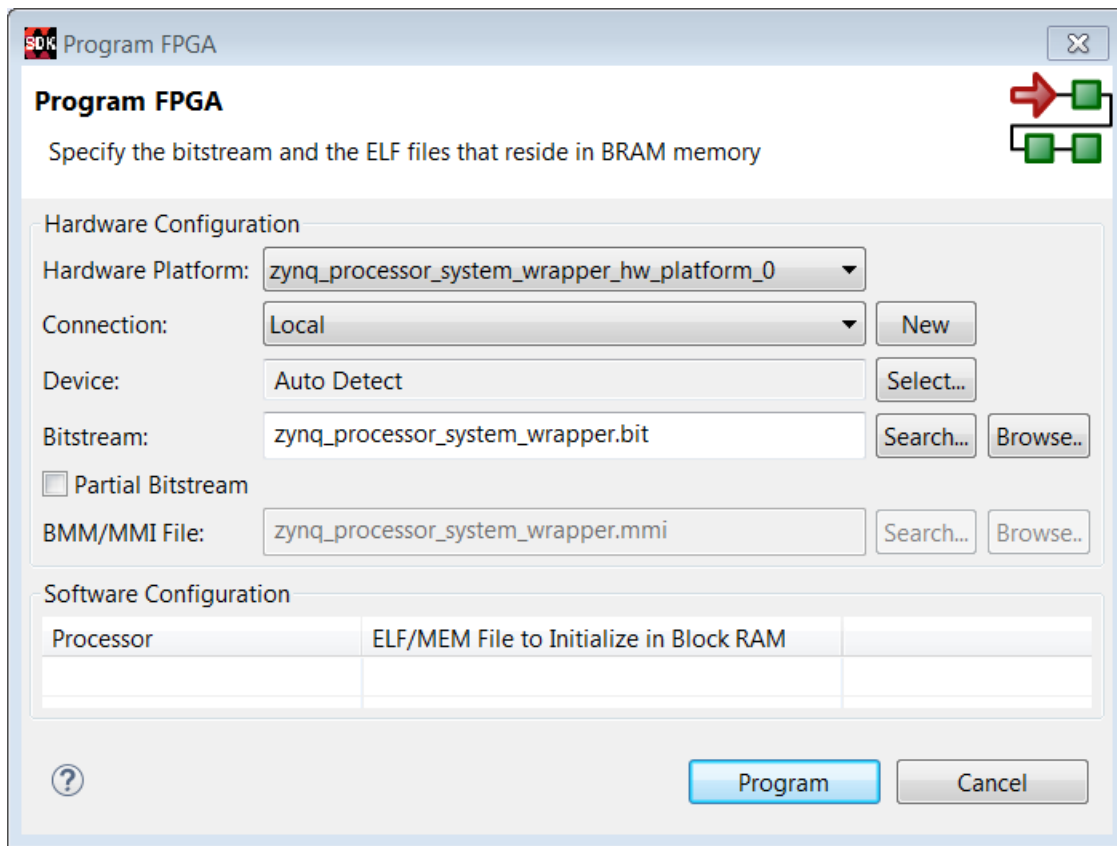

Figure 61: Program FPGA Dialog Box

- Select and right-click the **peri_test** application in the Project Explorer, and select **Debug As > Debug Configurations**.

The Debug Configurations dialog box opens.

10. Right-click **Xilinx C/C++ application (System Debugger)**, and select **New**.

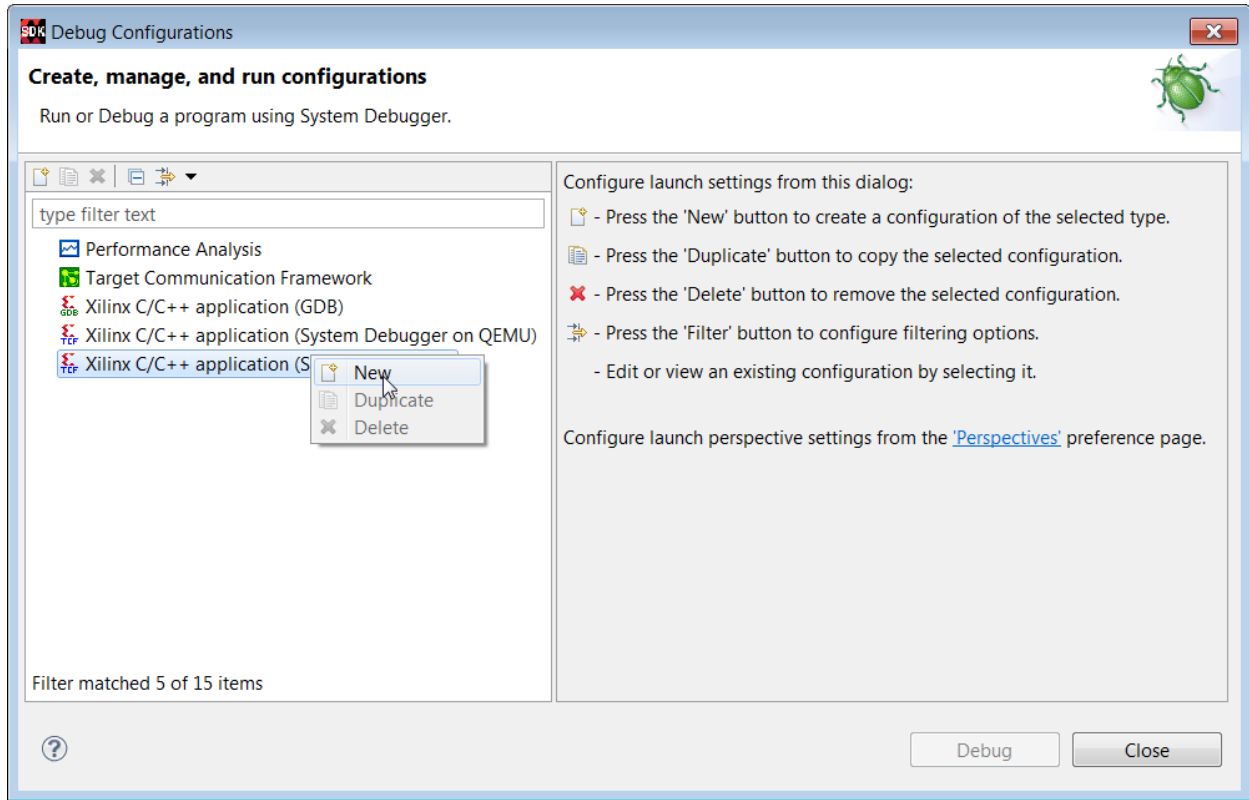

Figure 62: Create New Debug Configuration

11. In the Create, manage, and run configurations screen, select the Target Setup tab and check the **Enable Cross triggering** check box.

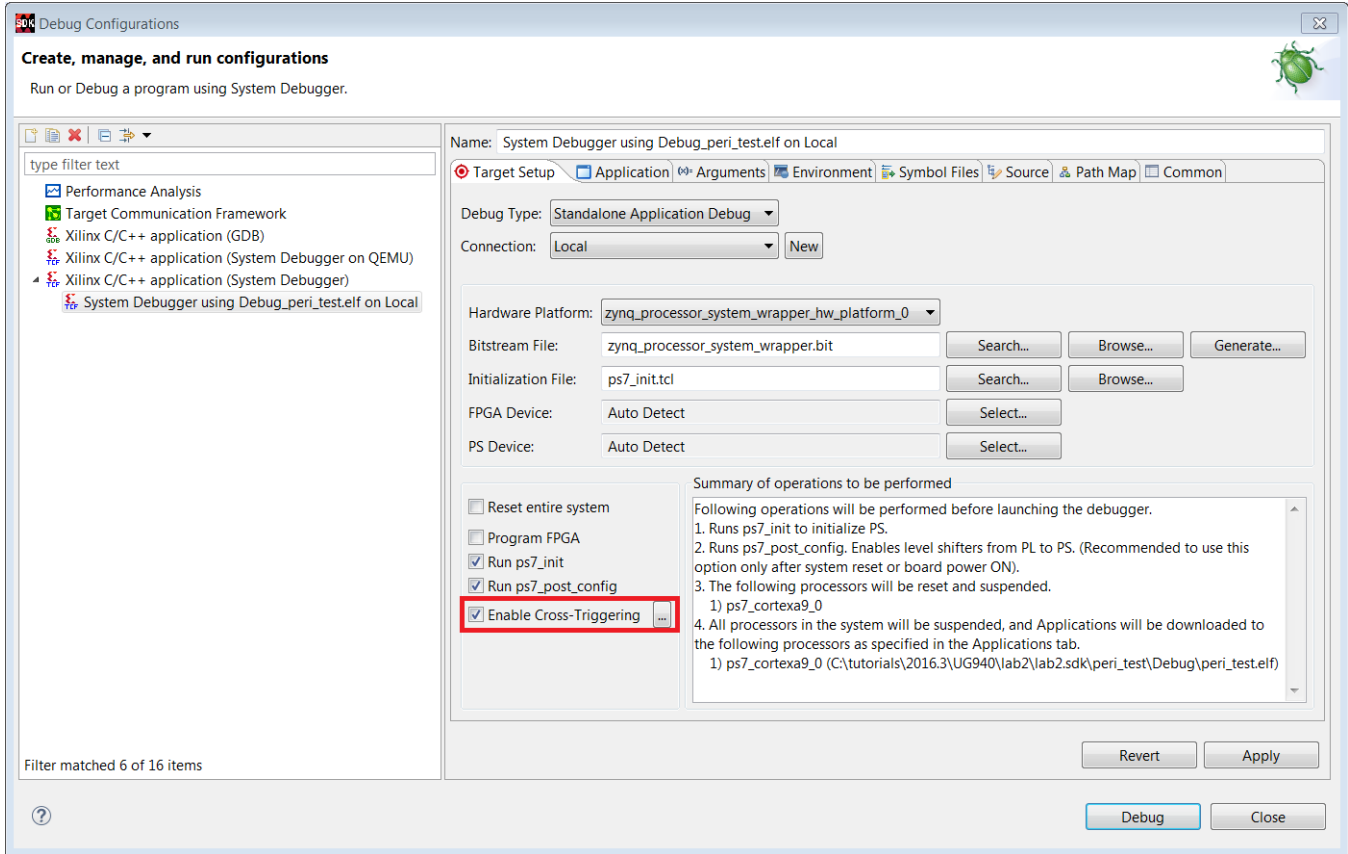

Figure 63: Debug Configurations dialog box

12. Click the **Browse** button for Enable Cross-Triggering option as shown in Figure 61.

13. When the Cross Trigger Breakpoints dialog box opens, click **Create**.

14. In the Create Cross Trigger Breakpoint page, select the options as shown in Figure 64.

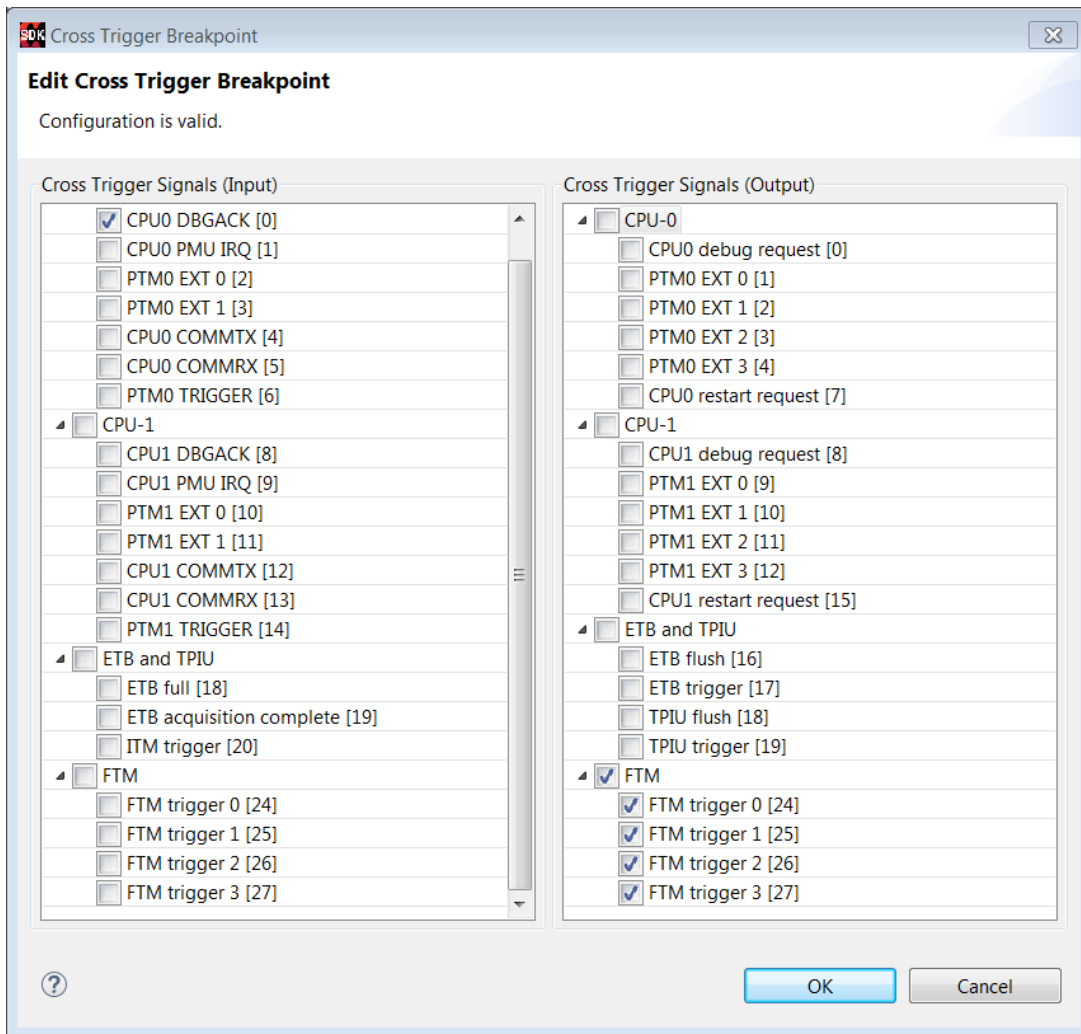

Figure 64: Setting Cross-Trigger Breakpoints for processor to fabric trigger

15. Click **OK**. This sets up the cross trigger condition for Processor to Fabric.
16. In the Cross Trigger Breakpoints dialog box click **Create** again, as shown in the following figure:

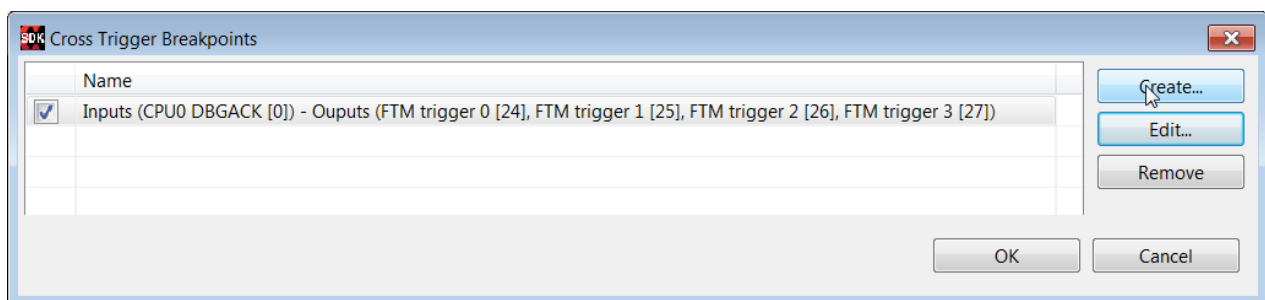

Figure 65: Setting Breakpoints forCross-Triggering Between Fabric and Processor

17. In the Create Cross Trigger Breakpoint page, select the options as shown in the following figure:

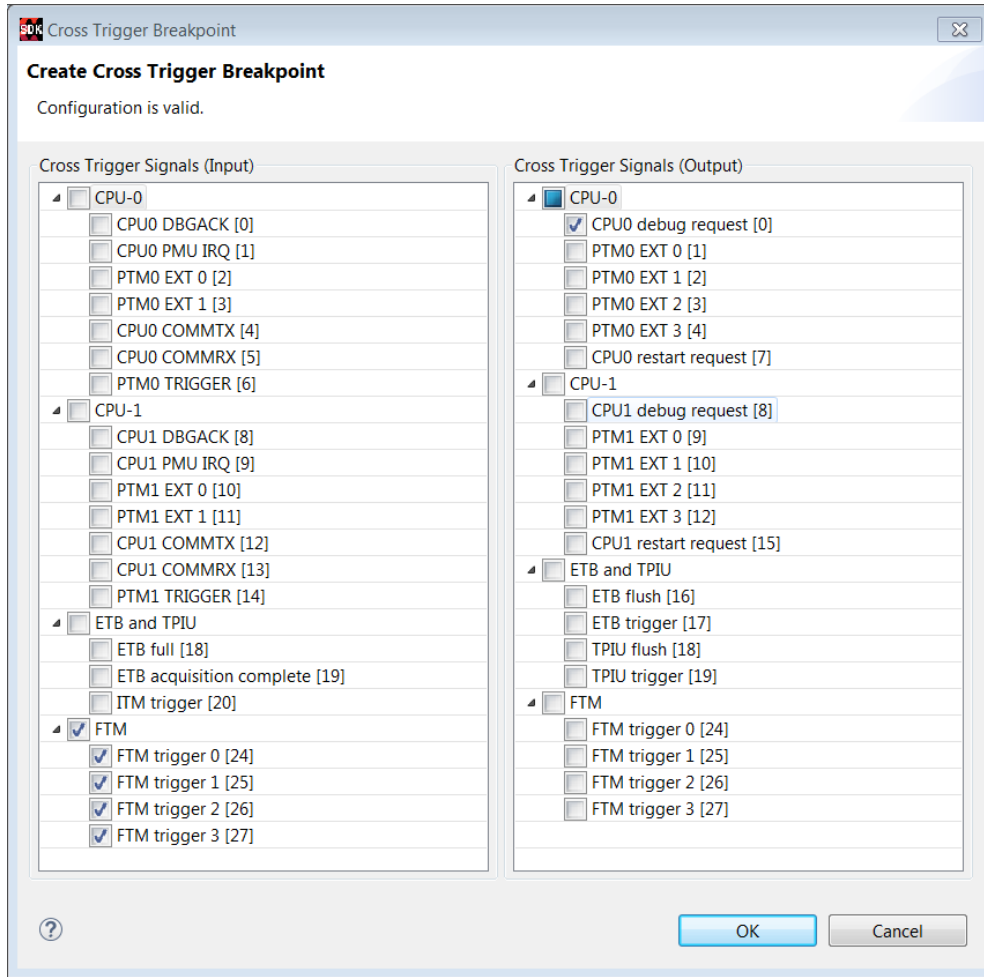

Figure 66: Setting Cross-Trigger Breakpoints for processor to fabric trigger

18. Click **OK**. This sets up the cross trigger condition for Fabric to Processor.

19. In the Cross Trigger Breakpoints dialog box click **OK**.

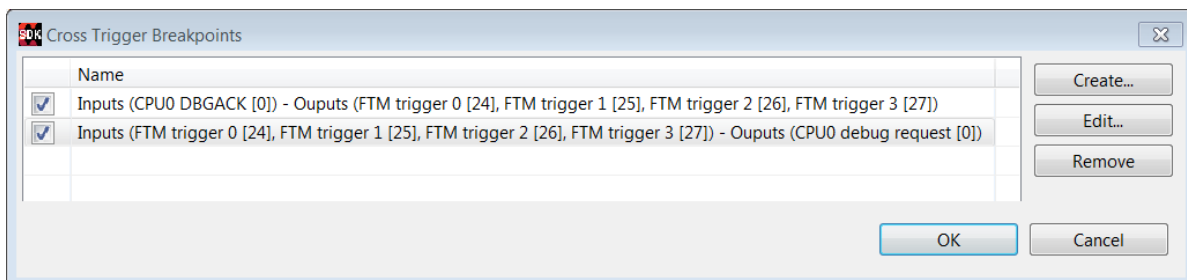

Figure 67: Cross Trigger Breakpoints dialog box showing the selection for breakpoint

20. In the Debug Configurations dialog box, click **Debug**, as shown at the bottom of the following figure.

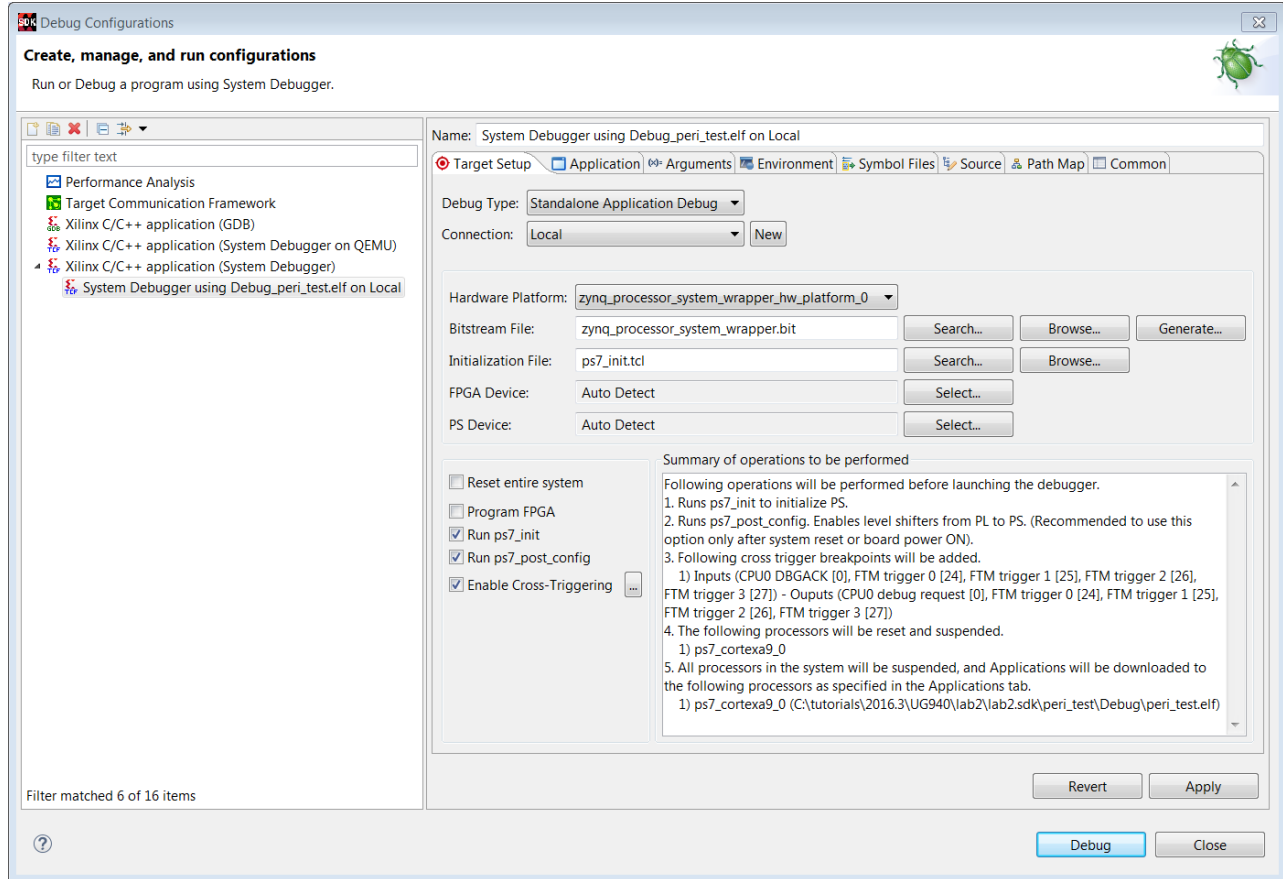

Figure 68: Debug Configurations dialog box after setting breakpoints

The **Confirm Perspective Switch** dialog box opens.

21. Click **Yes** to confirm the perspective switch.

The Debug perspective window opens.

22. Set the terminal by selecting the **SDK Terminal** tab and clicking the  icon.

23. Use the following settings in the following figure for the ZC702 board, and click **OK**.

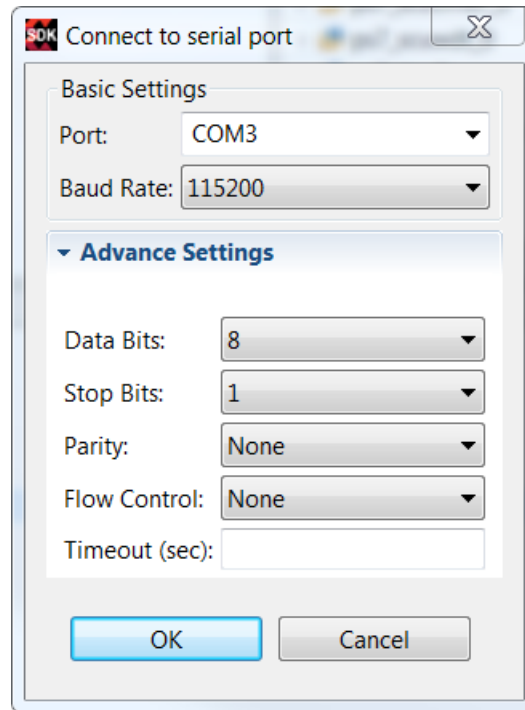

Figure 69: Terminal Settings

24. Verify the Terminal connection by checking the status at the top of the tab as shown in the following figure.

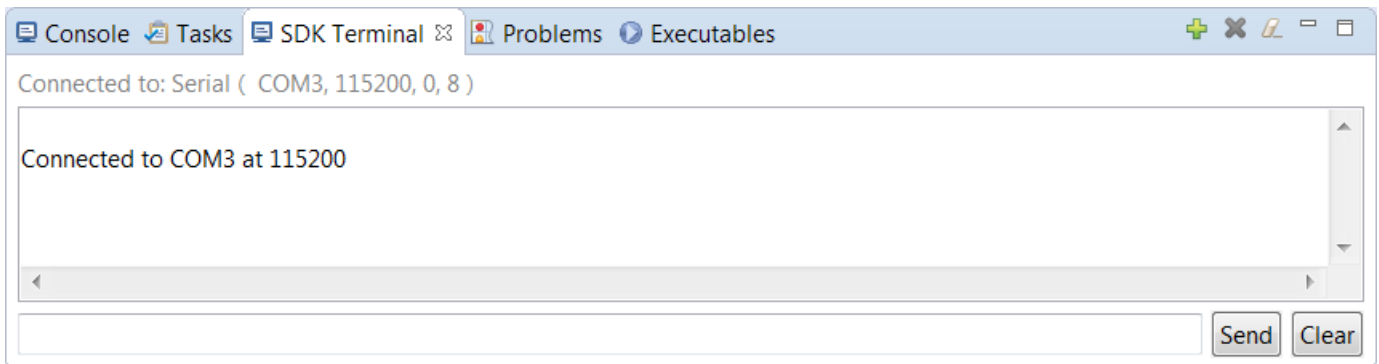
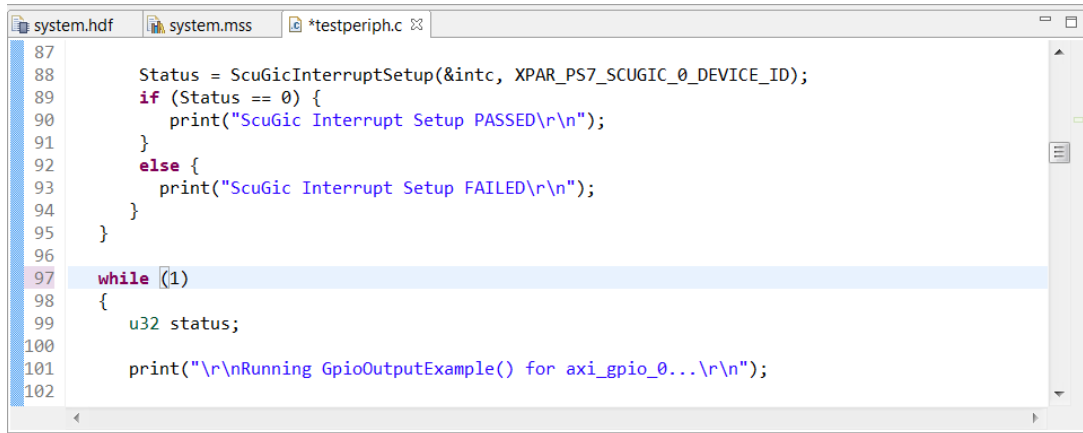

Figure 70: Verify Terminal Connection

25. If it is not already open, select `../src/testperiph.c`, and double click to open the source file.

26. Click the blue bar on the left side of the `testperiph.c` window as shown in the figure and select **Show Line Numbers**.
27. Modify the source file by inserting a `while` statement at approximately line 97.
28. After the `else` statement, add `while (1)` above in front of the curly brace as shown in the following figure.



```

87
88     Status = ScuGicInterruptSetup(&intc, XPAR_PS7_SCUGIC_0_DEVICE_ID);
89     if (Status == 0) {
90         print("ScuGic Interrupt Setup PASSED\r\n");
91     }
92     else {
93         print("ScuGic Interrupt Setup FAILED\r\n");
94     }
95 }
96
97 while (1)
98 {
99     u32 status;
100
101     print("\r\nRunning GpioOutputExample() for axi_gpio_0...\r\n");
102

```

Figure 71: Modify testperiph.c

29. Add a breakpoint in the code so that the processor stops code execution when the breakpoint is encountered. To do so, scroll down to the line after the “while” statement starts, and double-click the left pane, which adds a breakpoint on that line of code, as it appears in the following figure. Click **Ctrl + S** to save the file. Alternatively, you can select **File > Save**.

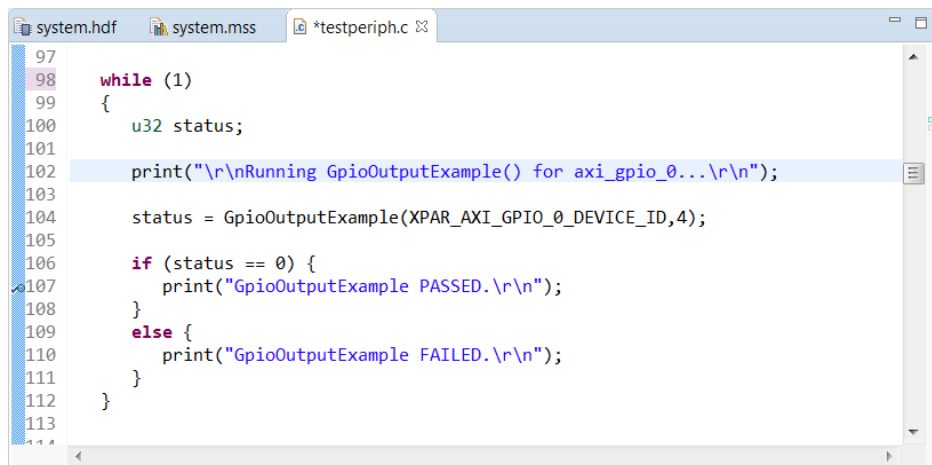

```

97
98     while (1)
99     {
100         u32 status;
101
102         print("\r\nRunning GpioOutputExample() for axi_gpio_0...\r\n");
103
104         status = GpioOutputExample(XPAR_AXI_GPIO_0_DEVICE_ID,4);
105
106         if (status == 0) {
107             print("GpioOutputExample PASSED.\r\n");
108         }
109         else {
110             print("GpioOutputExample FAILED.\r\n");
111         }
112     }
113

```

Figure 72: Set a Breakpoint

Now you are ready to execute the code from SDK.

Step 6: Connect to Vivado Logic Analyzer

Connect to the ZC702 board using the Vivado Logic Analyzer.

1. In the Vivado IDE session, from the **Program and Debug** drop-down list of the **Vivado Flow Navigator**, select **Open Hardware Manager**.
2. In the Hardware Manager window, click **Open target > Open New Target**.

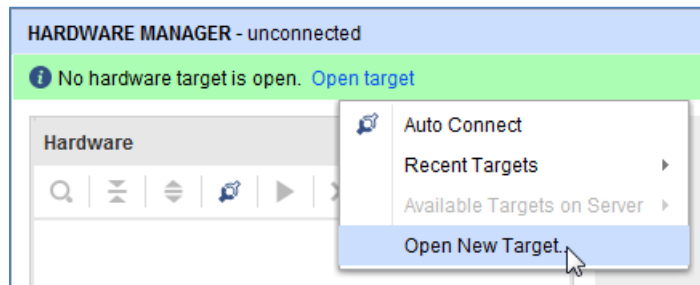

Figure 73: Open a New Hardware Target

Note: You can also use the Auto Connect option to connect to the target hardware.

The **Open New Hardware Target** dialog box opens, shown in the following figure.



Figure 74: Open Hardware Target

3. Click **Next**.

- On the Hardware Server Settings page, ensure that the Connect to field is set to **Local server (target is on local machine)** as shown in the following figure, and click **Next**.

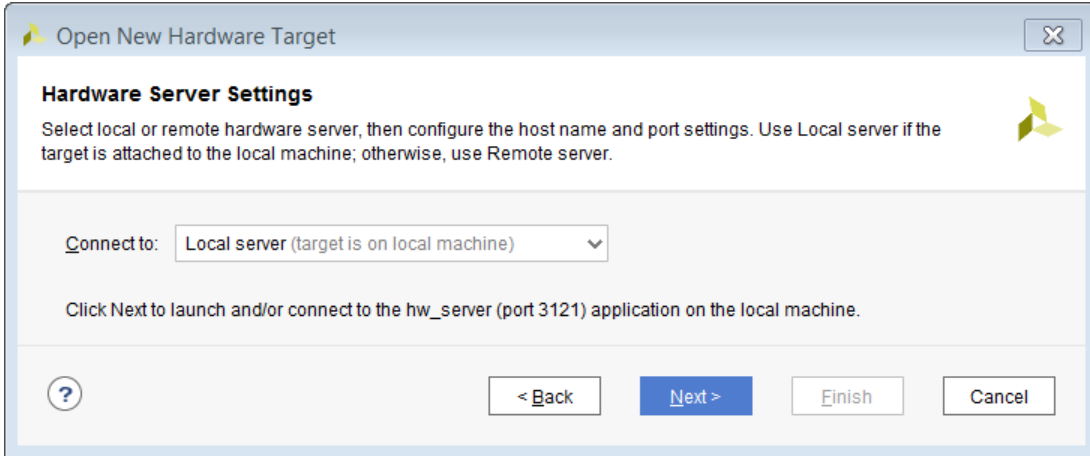

Figure 75: Specify Server Name

- On the Select Hardware Target page, click **Next**.

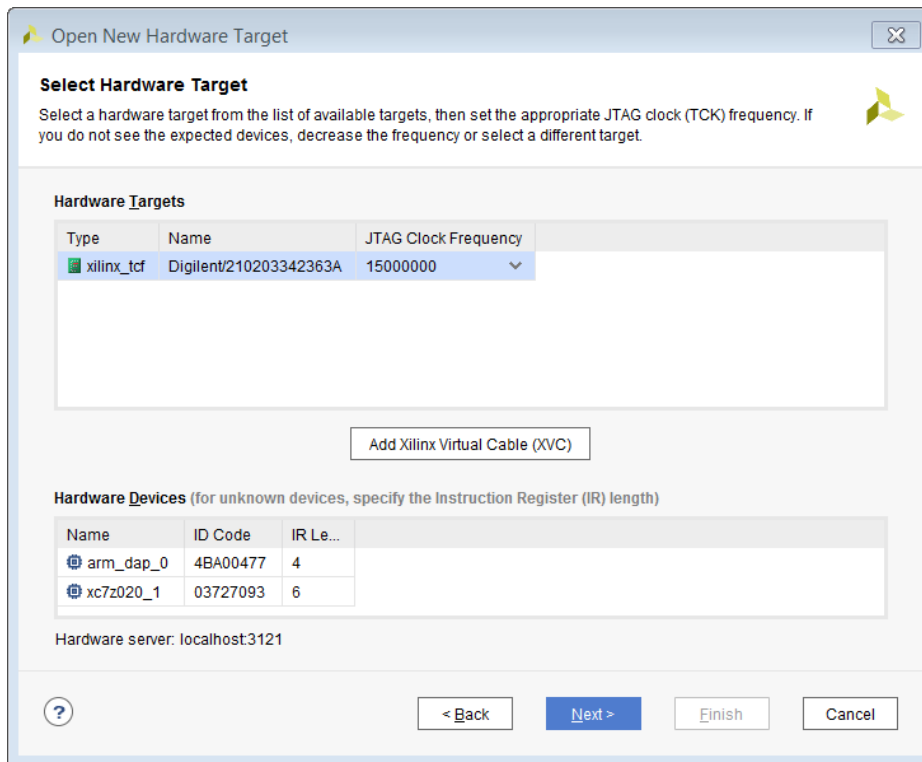

Figure 76: Select Hardware Target

- Ensure that all the settings are correct on the **Open Hardware Target Summary** dialog box, as shown in the following figure, and click **Finish**.

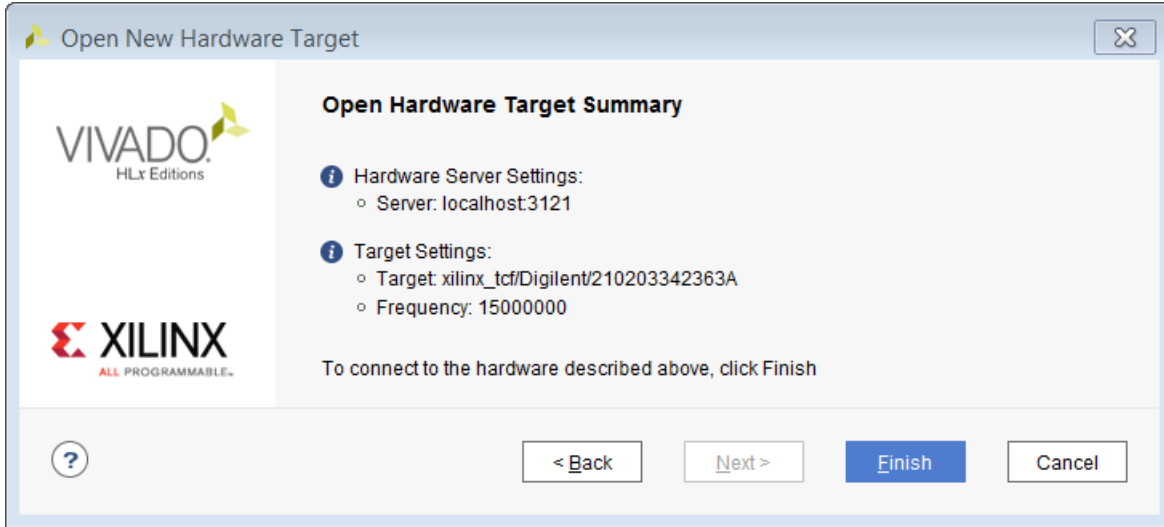

Figure 77: Open Hardware Target Summary

Step 7: Setting the Processor to Fabric Cross Trigger

When the Vivado Hardware Session successfully connects to the ZC702 board, you see the information shown in the following figure.

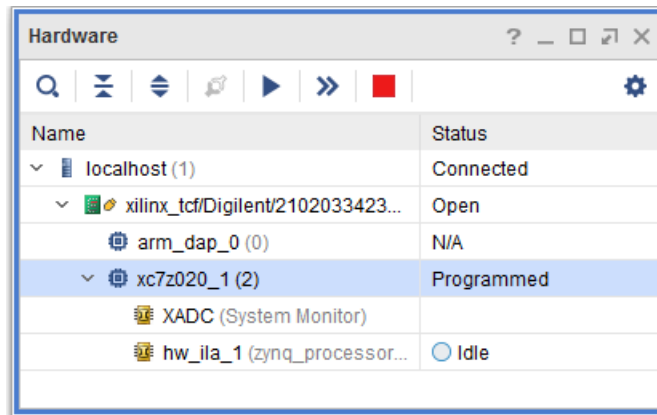

Figure 78: Vivado Hardware Window

1. Select the ILA - hw_ila_1 tab and set the **Trigger Mode Settings** as follows:
 - Set **Trigger** mode to **TRIG_IN_ONLY**
 - Set **TRIG_OUT** mode to **TRIG_IN_ONLY**
 - Under **Capture Mode Settings**, change **Trigger position in window** to 512.

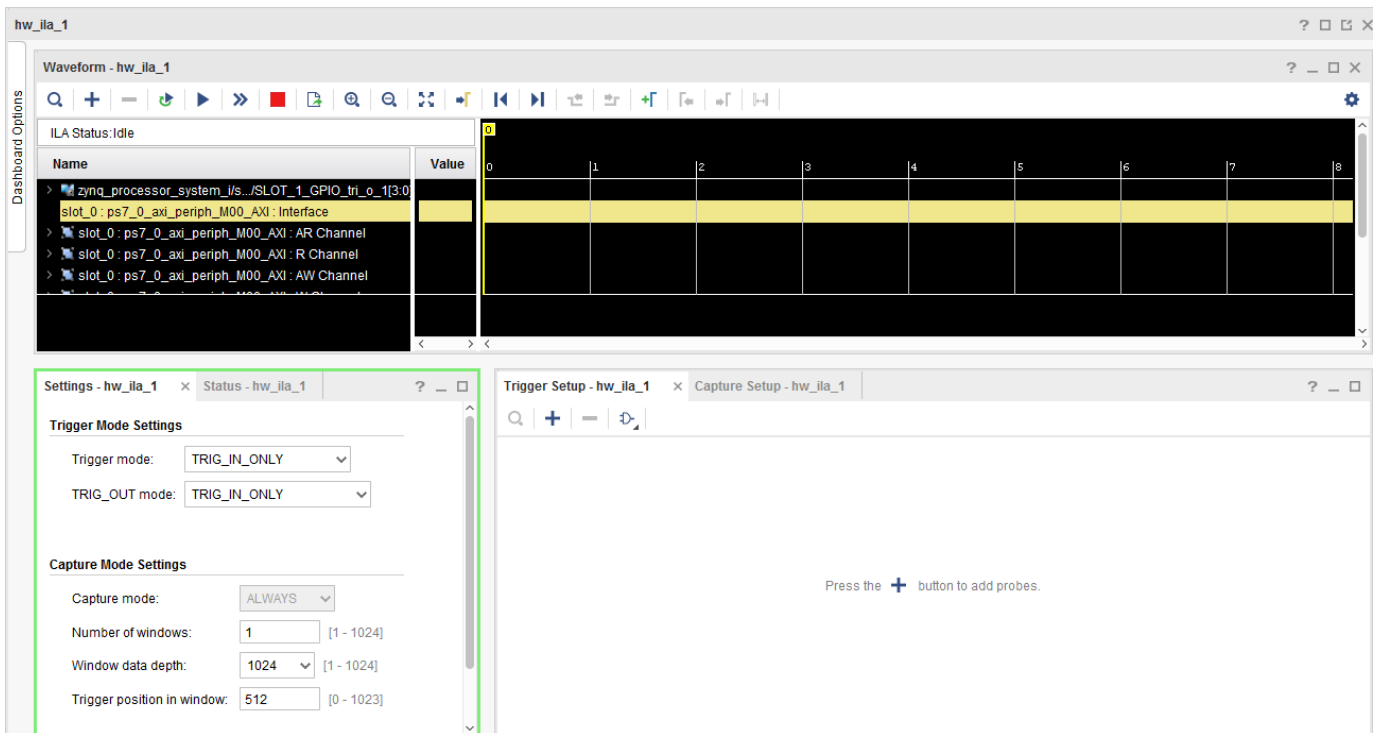

Figure 79: Set ILA Properties for hw_ila_1

2. Arm the ILA core by clicking the **Run Trigger** button .

This arms the ILA and you should see the status "Waiting for Trigger" as shown in the following figure.

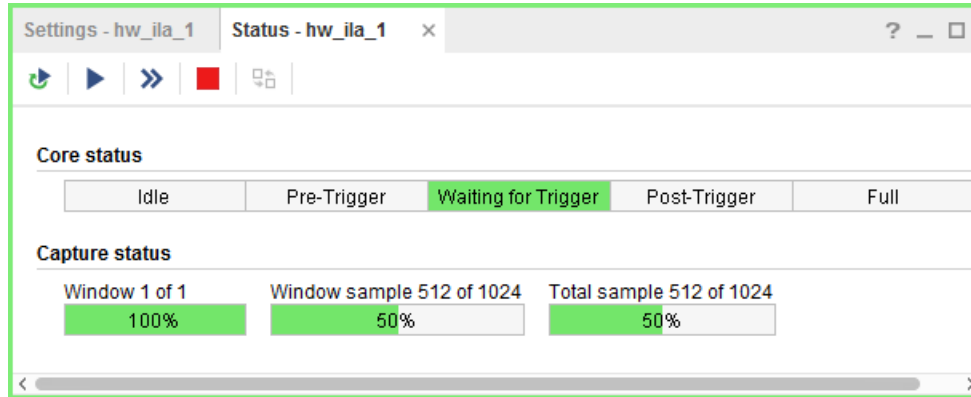



Figure 80: Armed ILA Core

3. In SDK, in the Debug window, click the **Resume** button  in the SDK toolbar, until the code execution reaches the breakpoint set on line 107 in the testperiph.c file.
4. As the code hits the breakpoint, the processor sends a trigger to the ILA. The ILA has been set to trigger when it sees the trigger event from the processor. The waveform window displays the state of various signals as seen in the following figure.

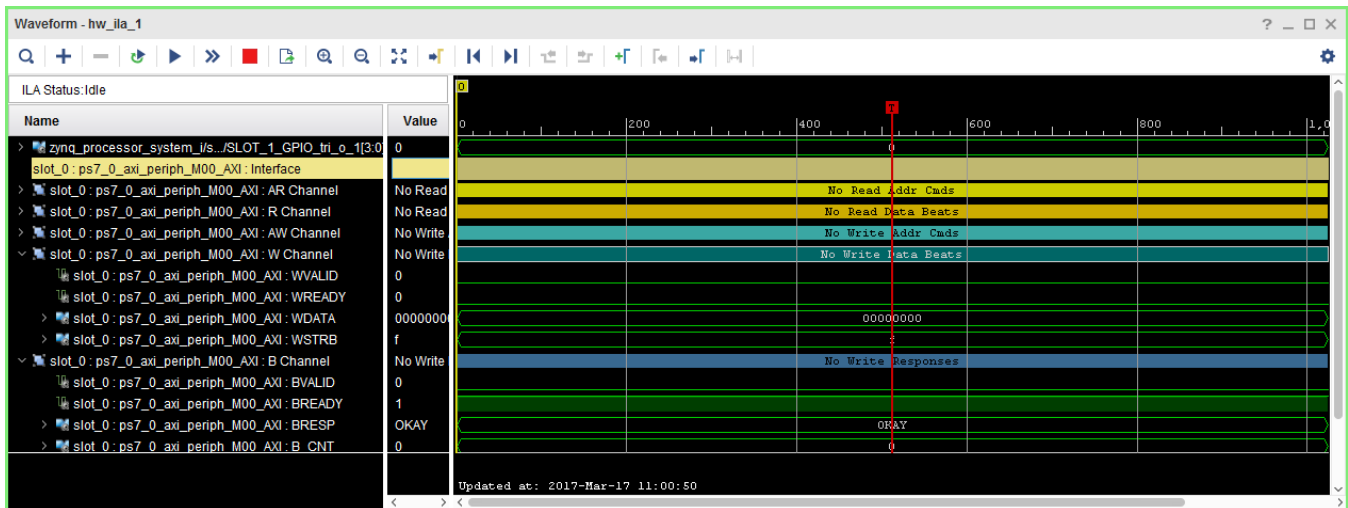

Figure 81: PS to PL Cross Trigger Waveform in hw_ila_1

This demonstrates that when the breakpoint is encountered during code execution, the PS7 triggers the ILA that is set up to trigger. The state of a particular signal when the breakpoint is encountered can be monitored in this fashion.

Step 8: Setting the Fabric to Processor Cross-Trigger

Now try the fabric to processor side of the cross-trigger mechanism. To do this remove the breakpoint that you set earlier on line 107 to have the ILA trigger the processor and stop code execution.

1. In SDK, select the Breakpoints tab towards the top right corner of SDK window, right-click it, and uncheck the `testperiph.c [line: 106]` checkbox. This removes the breakpoint that you set up earlier.

Note: Alternatively, you can select the breakpoint in line 107 of the `testperiph.c` file, right click and select **Disable Breakpoint**.

2. In the Debug window, click **Resume** icon on the SDK toolbar. The code runs continuously because it has an infinite loop.

You can see the code executing in the Terminal Window in SDK.

3. In Vivado, select the Settings – `hw_ila_1` tab. Change the Trigger Mode to **BASIC_OR_TRIG_IN** and the `TRIG_OUT` mode to **TRIGGER_OR_TRIG_IN**.
4. Click on the + sign in the Trigger Setup window to add the `slot_0:ps7_0_axi_periph_M00_AXI:AWVALID` signal from the Add Probes window.
5. In the Basic Trigger Setup window, ensure that the **Radix** is set to [B] Binary and change the **Value** for the `slot_0:ps7_0_axi_periph_M00_AXI:AWVALID` signal to **1**. This essentially sets up the ILA to trigger when the `awvalid` transitions to a value of 1.
6. Click the **Run Trigger** button  to “arm” the ILA. It triggers immediately as the SDK code is running AXI transactions which causes the `awvalid` signal to toggle. This causes the `trigger_out` of the ILA to toggle which eventually will halt the processor from executing the code.

This is seen in SDK the in the highlighted area of the debug window.

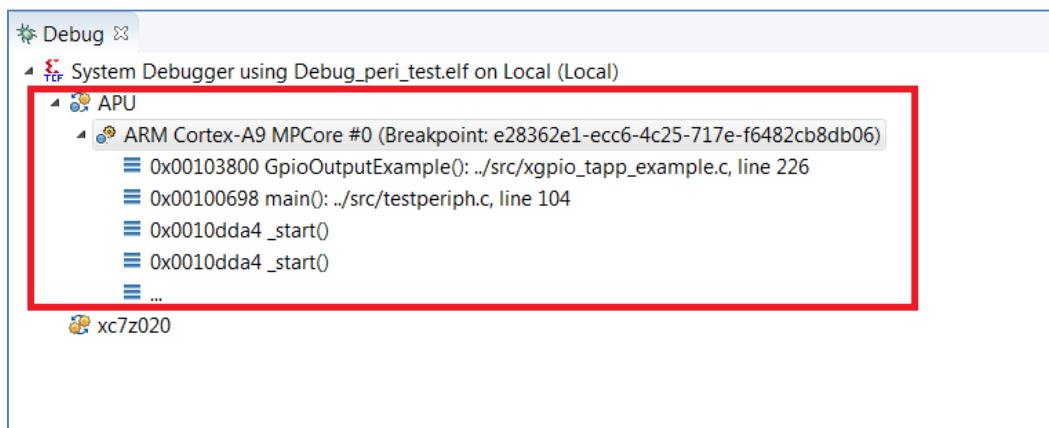

Figure 82: Verify that the Processor Has Been Interrupted in SDK

Conclusion

This lab demonstrated how cross triggering works in a Zynq-7000 AP SoC processor based design. You can use cross triggering to co-debug hardware and software in an integrated environment.

Lab Files

This tutorial demonstrates the cross-trigger feature of the Zynq-7000 AP SoC processor, which you perform in the GUI environment. Therefore, the only Tcl file provided is `lab2.tcl`.

The `lab2.tcl` file helps you run all the steps all the way to exporting hardware for SDK.

The debug portion of the lab must be carried out in the GUI; no Tcl files are provided for that purpose.

Lab 3: Using the Embedded MicroBlaze Processor

Introduction

In this tutorial, you create a simple MicroBlaze™ system for a Kintex®-7 FPGA using Vivado® IP integrator.

The MicroBlaze system includes native Xilinx IP including:

- MicroBlaze processor
- AXI block RAM
- Double Data Rate 3 (DDR3) memory
- UARTLite
- GPIO
- Debug Module (MDM)
- Proc Sys Reset
- Local memory bus (LMB)

Parts of the block design are constructed using the Platform Board Flow feature. This lab also shows the cross-trigger capability of the MicroBlaze processor. The feature is demonstrated using a software application code developed in SDK in a stand-alone application mode.

This lab targets the Xilinx KC705 FPGA Evaluation Board.

Step 1: Invoke the Vivado IDE and Create a Project

1. Open the Vivado IDE by clicking the desktop icon or by typing `vivado` at a terminal command line.
2. From the Quick Start page, select **Create New Project**.
The New Project wizard opens.
3. In the **Project Name** dialog box, type the project name and location. Make sure that **Create project subdirectory** is checked. Click **Next**.
4. In the **Project Type** dialog box, select **RTL Project**. Click **Next**.
5. In the **Add Sources** dialog box, ensure that the **Target language** is set to **VHDL** or **Verilog**. Set the **Simulator language** to **Mixed**.

6. Click **Next**.
7. In **Add Constraints** dialog box, click **Next**.
8. In the Default Part dialog box, select **Boards** and choose the **Kintex-7 KC705 Evaluation Platform** along with the correct version. Click **Next**.
9. Review the project summary in the **New Project Summary** dialog box before clicking **Finish** to create the project.

Because you selected the KC705 board when you created the Vivado IDE project, you see the following message in the Tcl Console:

```
set_property board part xilinx.com:kc705:part0:1.5 [current_project]
```

Although Tcl commands are available for many of the actions performed in the Vivado IDE, they are not explained in this tutorial. Instead, a Tcl script is provided that can be used to recreate this entire project. See the Tcl Console for more information. You can also refer to the *Vivado Design Suit Tcl Command Reference Guide* ([UG835](#)) for information about the [write_bd_tcl](#) commands.

Step 2: Create an IP Integrator Design

1. From Flow Navigator, under IP integrator, select **Create Block Design**.

The Create Block Design dialog box opens.

2. Specify the IP subsystem design name. For this step, you can use `mb_subsystem` as the Design name. Leave the Directory field set to its default value of **<Local to Project>**. Leave the Specify source set drop-down list set to its default value of **Design Sources**.
3. Click **OK** in the Create Block Design dialog box, shown in the following figure:

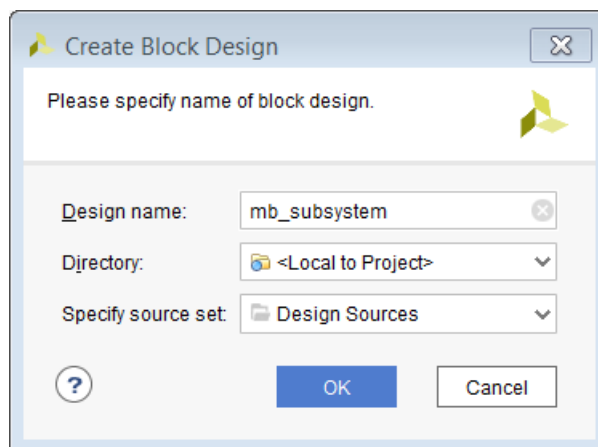

Figure 83: Name Block Design

- In the IP integrator diagram area, right-click and select **Add IP**.

The IP integrator Catalog opens. Alternatively, you can also select the **Add IP** icon in the middle of the canvas.

This design is empty. Press the **+** button to add IP.

Figure 84: Add IP

- As shown in the following figure, type **micr** in the Search field to find the MicroBlaze IP, then select **MicroBlaze** and press the **Enter** key.

Note: The IP Details window can be displayed by clicking **CTRL+Q** key on the keyboard.

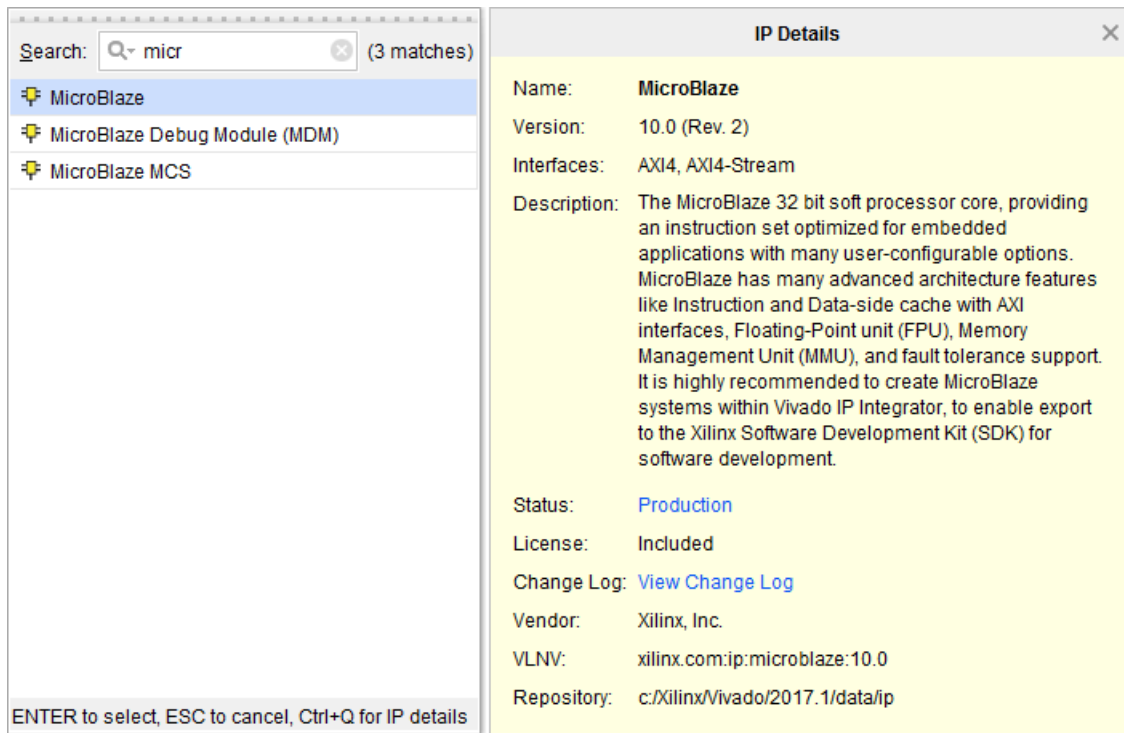

Figure 85: Search Field

Use the Board Tab to Connect to Board Interfaces

There are several ways to use an existing interface in IP Integrator. Use the Board tab to instantiate some of the interfaces that are present on the KC705 board.

1. Click the **Board** tab. You can see that there are several components listed in that tab. These components are present on the KC705 board. These components are all listed under different categories in the Board window.

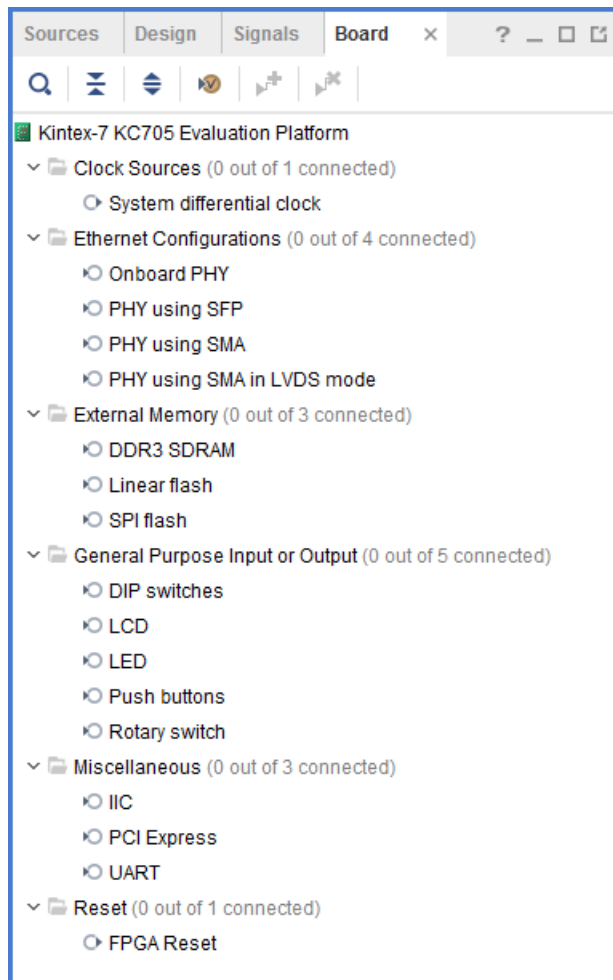

Figure 86: Using the Board Part Interfaces to Configure a Memory IP

2. From the **External Memory** folder, drag and drop the DDR3 SDRAM component into the block design canvas.

The Auto Connect dialog box opens, as shown in the following figure, informing you that the Memory IP was instantiated on the block design and then connected to DDR3 SDRAM component on the board.

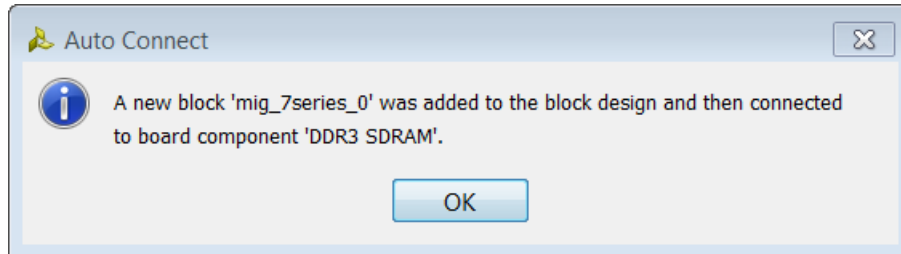

Figure 87: Auto-connect dialog box for DDR3

Note: The order of instantiation of these IP are important as they affect the options available with Designer Assistance. As an example, when the DDR3 component is instantiated, the Block Automation option for the MicroBlaze will enable caching by default.

3. Click **OK**.

The block design looks like the following figure:

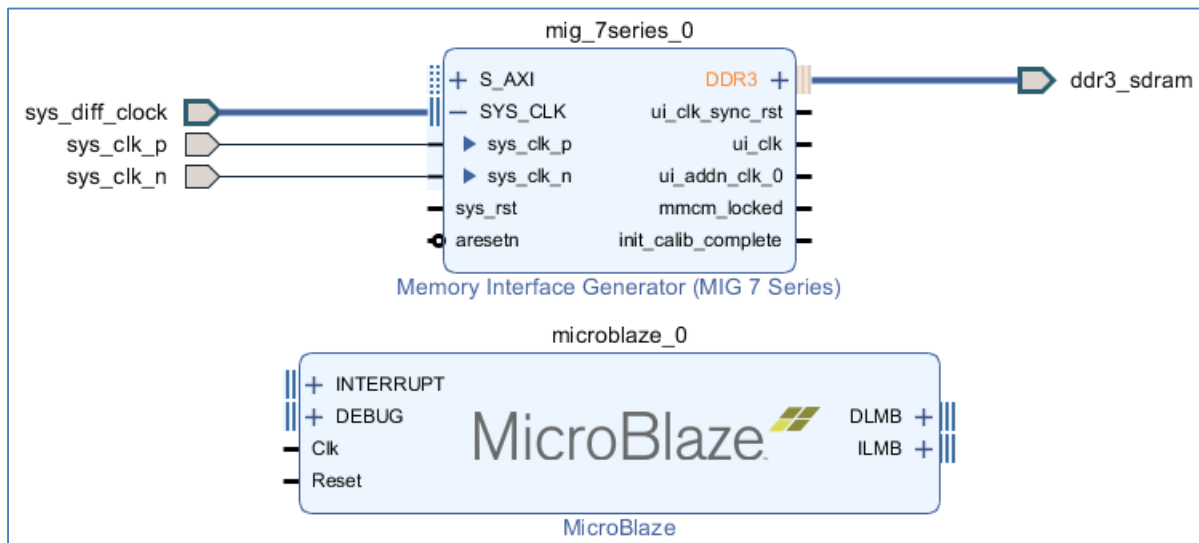



Figure 88: Block Design After Instantiating the Memory IP Core

- In the Board window, notice that the DDR3 SDRAM interface now is connected as shown by the circle  in the following figure:

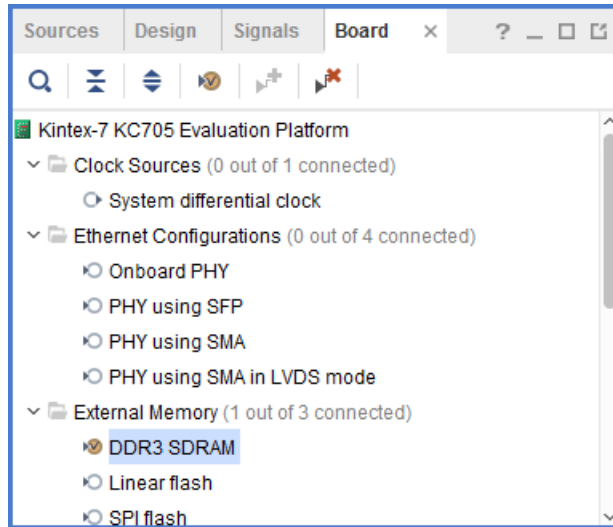

Figure 89: DDR3 Interface Shown Under Connected Interfaces

- From the Board window, select **UART** under the miscellaneous folder and drag and drop it into the block design canvas.
- Click **OK** in the Auto Connect dialog box.
This instantiates the AXI Uartlite IP on the block design.
- Likewise, from the Board window, select **LED** under the General Purpose Input or Output folder and drag and drop it into the block design canvas.
- Click **OK** in the Auto Connect dialog box.
This instantiates the GPIO IP on the block design and connects it to the on-board LEDs.
- The block design now should look like Figure 90.

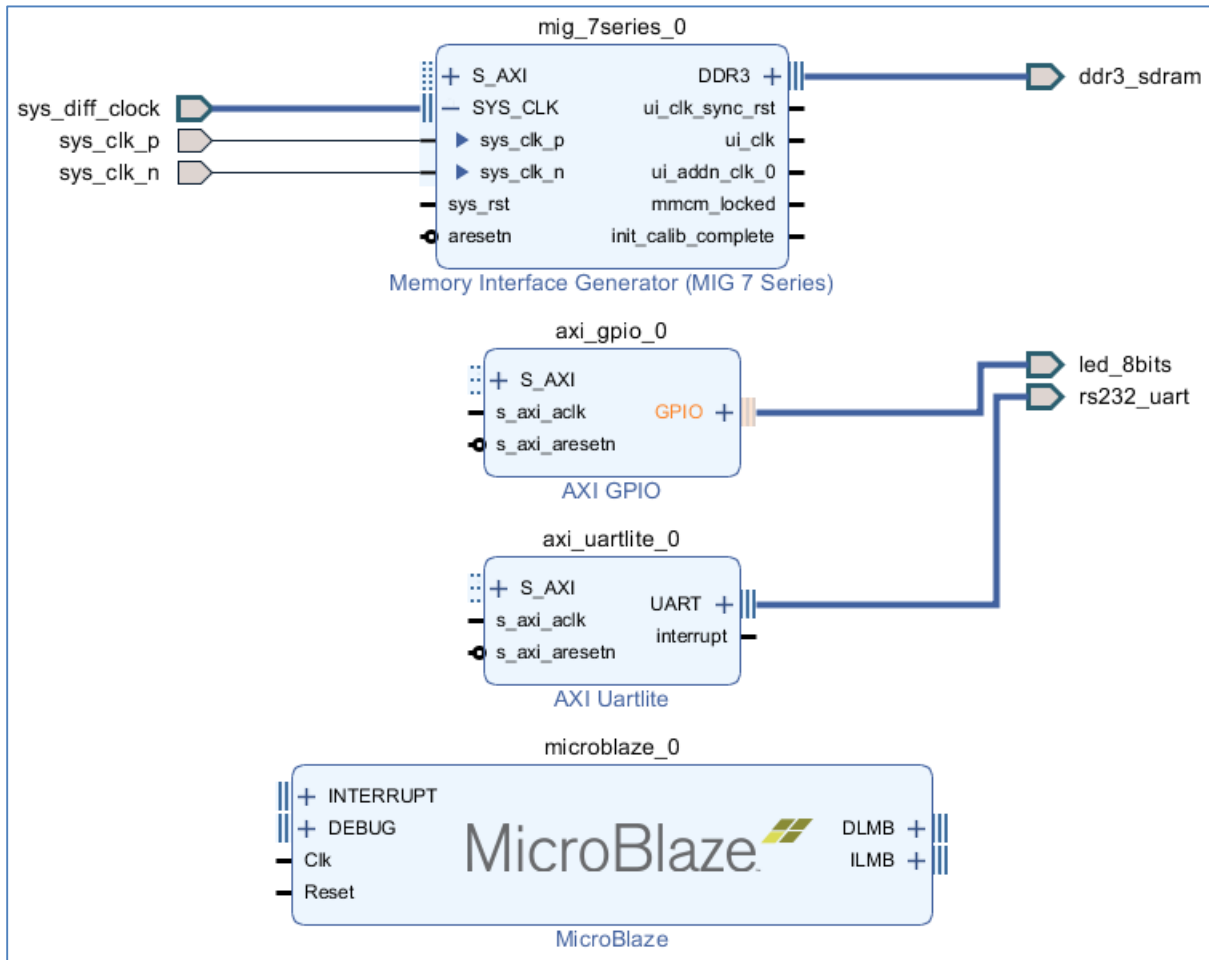

Figure 90: Block Design After Connecting the rs232_uart and the led_8bits Interfaces

Add Peripheral: AXI BRAM Controller

1. Add the AXI BRAM Controller, shown in the following figure, by right-clicking the IPI canvas and selecting **Add IP**.

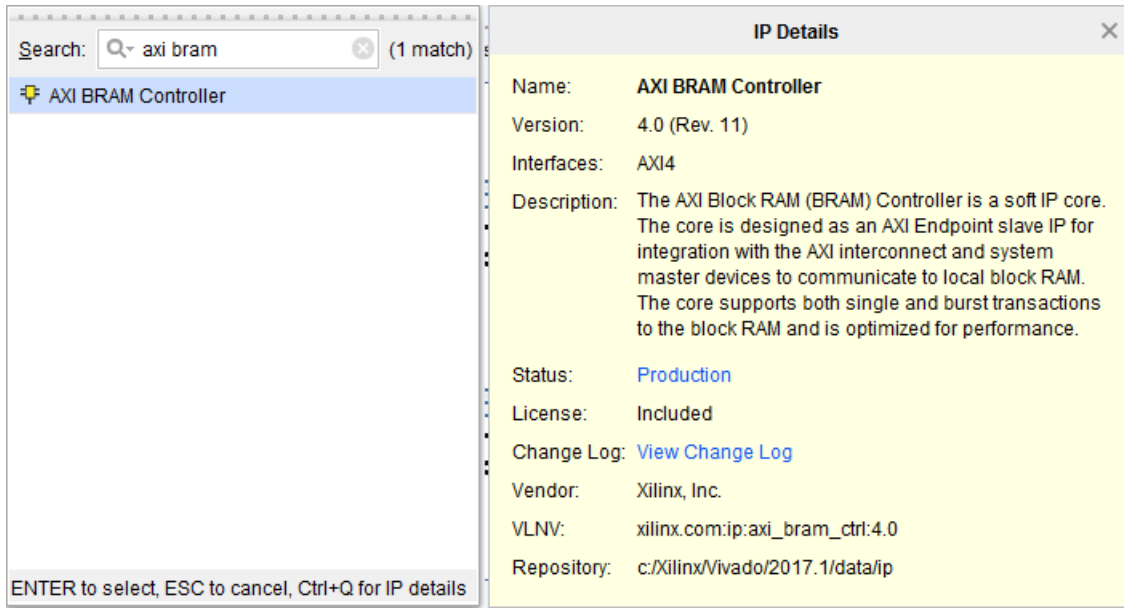

Figure 91: Add BRAM Controller

Run Block Automation

1. Click **Run Block Automation**, displayed in the following figure:



Figure 92: Run Block Automation

The Run Block Automation dialog box opens, as shown in the following figure.

The values of the fields shown in this figure show the values that you will set in the next step.

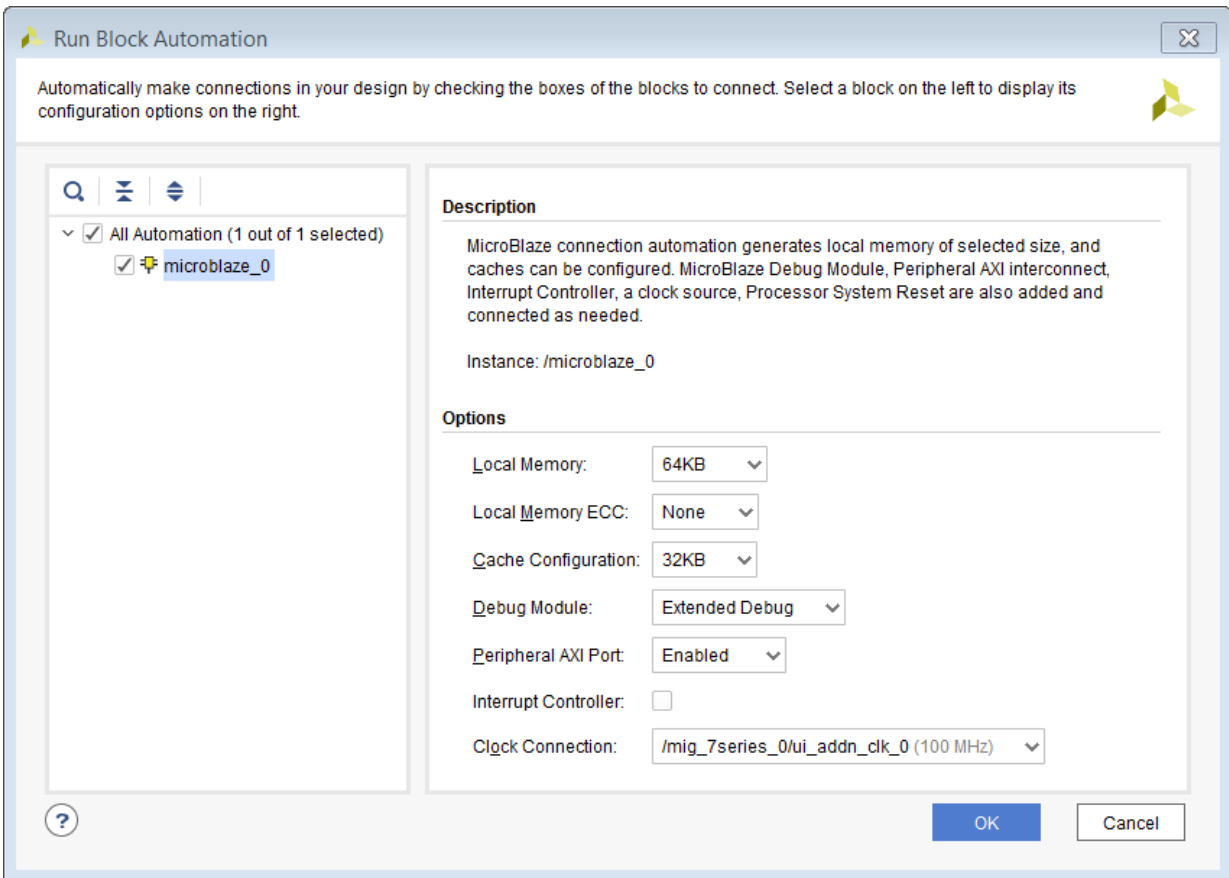

Figure 93: Run Block Automation Dialog Box

2. On the Run Block Automation page:
 - a. Set **Local Memory** to **64 KB**.
 - b. Leave the **Local Memory ECC** to its default value of **None**.
 - c. Change the **Cache Configuration** to **32 KB**.
 - d. Change the **Debug Module** option to **Extended Debug**.
 - e. Leave the Peripheral AXI Port option set to its default value of **Enabled**.
 - f. Leave the **Clock Connection** option set to `/mig_7series_0/ui_addn_clk_0 (100 MHz)`.
3. Click **OK**.

This generates a basic **MicroBlaze** system in the IP Integrator diagram area, shown in Figure 94.

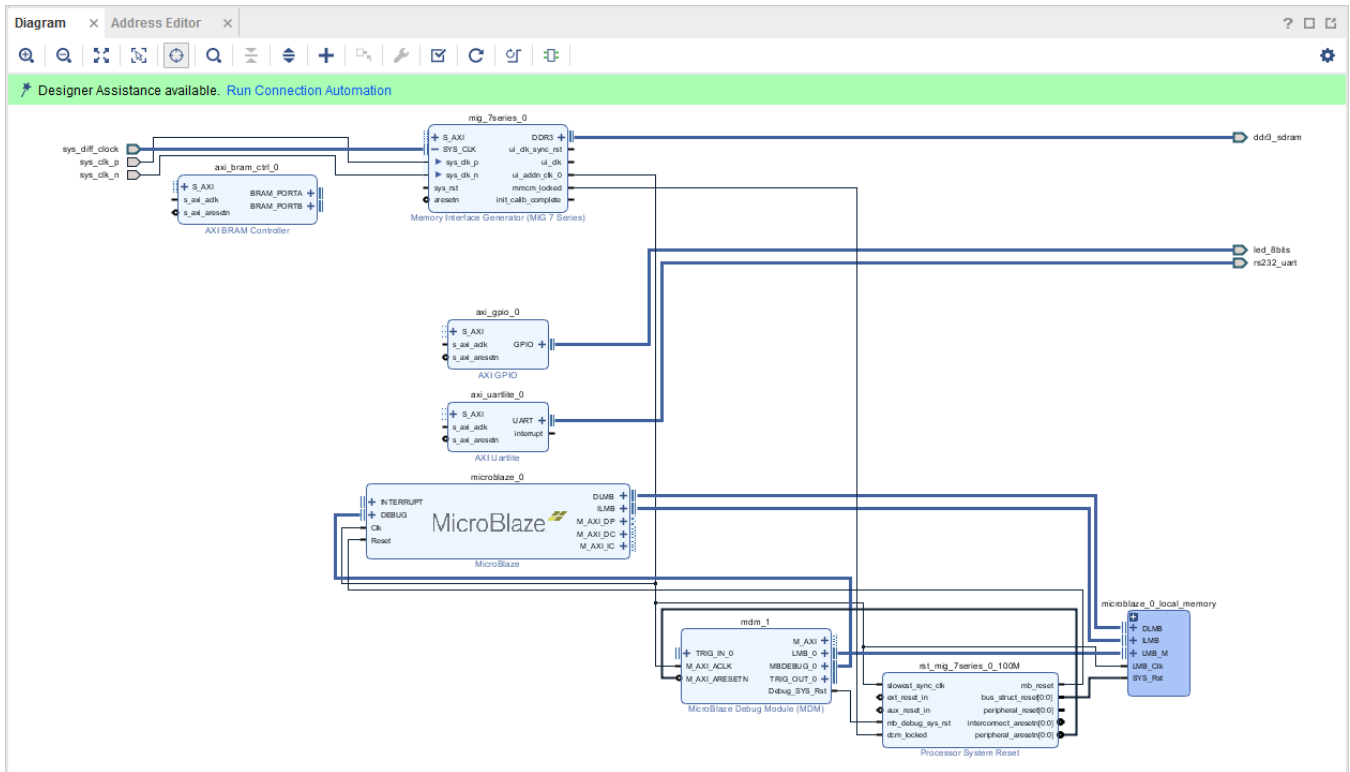

Figure 94: MicroBlaze System

Use Connection Automation

Run Connection Automation provides several options that you can select to make connections. This section will walk you through the first connection, and then you will use the same procedure to make the rest of the required connections for this tutorial.

1. Click **Run Connection Automation** as shown in the following figure.

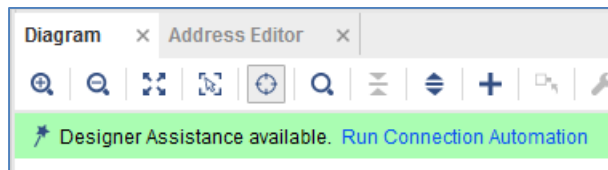

Figure 95: Run Connection Automation

The Run Connection Automation dialog box opens.

2. Check the interfaces in the left pane of the dialog box as shown in the following figure:

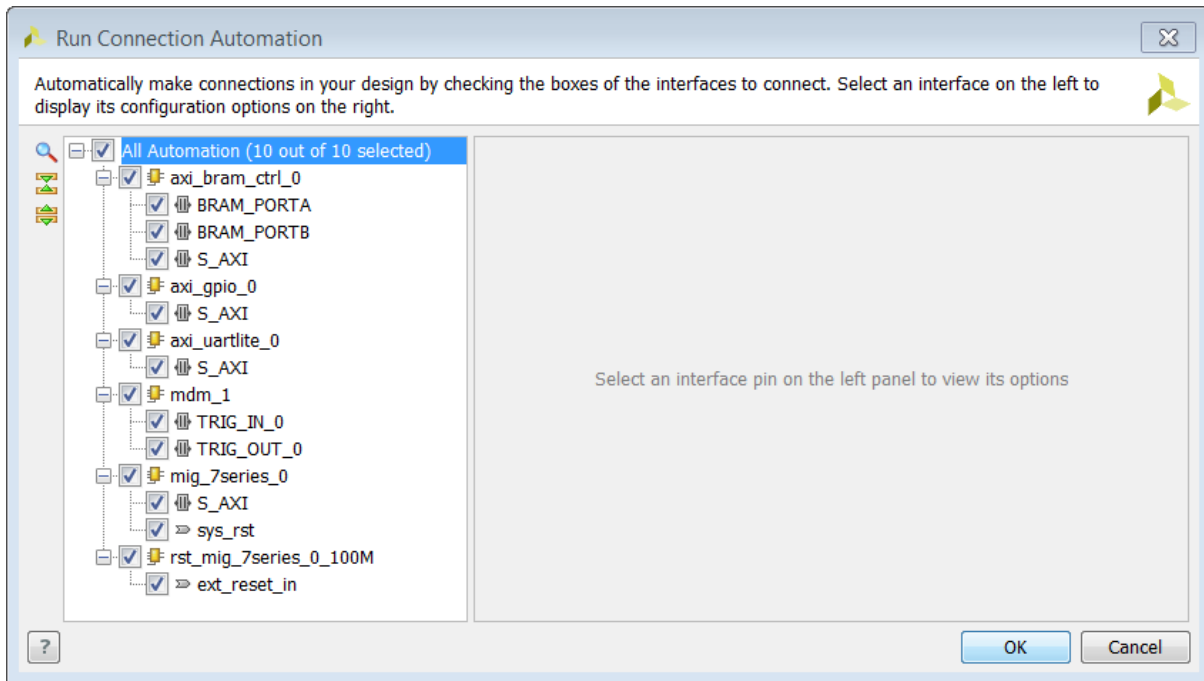

Figure 96: Run Connection Automation Dialog Box

3. Now, use the following table to set options in the Run Connection Automation dialog box.

Connection	More Information	Setting
axi_bram_ctrl_0 <ul style="list-style-type: none"> BRAM_PORTA 	The only option for this automation is to instantiate a new Block Memory Generator as shown under options.	Leave the Blk_Mem_Gen to its default option of Auto .
axi_bram_ctrl_0 <ul style="list-style-type: none"> BRAM_PORTB 	The Run Connection Automation dialog box opens and gives you two choices: Instantiate a new BMG and connect the PORTB of the AXI BRAM Controller to the new BMG IP Use the previously instantiated BMG core and automatically configure it to be a true dual-ported memory and connected to PORTB of the AXI BRAM Controller.	Leave the Blk_Mem_Gen option to its default value of Auto .
axi_bram_ctrl_0 <ul style="list-style-type: none"> S_AXI 	Two options are presented in this case. The Master field can be set for either cached or non-cached accesses.	The Run Connection Automation dialog box offers to connect this to the /microblaze_0 (Cached) . Leave it to its default value. In case, cached accesses are not desired this could be changed to /microblaze_0 (Periph) . Leave the Clock Connection (for unconnected clks) field set to its default value of Auto .
axi_gpio_0 <ul style="list-style-type: none"> S_AXI 	The Master field is set to /microblaze_0 (Periph) . The Clock Connection (for unconnected clks) field is set to its default value of Auto .	Keep these default settings.
axi_uartlite_0 <ul style="list-style-type: none"> S_AXI 	The Master field is set to its default value of /microblaze_0 (Periph) . The Clock Connection (for unconnected clks) field is set to its default value of Auto .	Keep these default settings.
mdm_1 <ul style="list-style-type: none"> TRIG_IN_0 	This will be connected to a new System ILA core's TRIG_OUT pin.	Leave the ILA Connection settings to its default value of Auto .
mdm_1 <ul style="list-style-type: none"> TRIG_OUT_0 	This will be connected to the System ILA core's TRIG_IN pin.	Leave the ILA Connections settings to its default value of Auto .
mig_7series_0 <ul style="list-style-type: none"> S_AXI 	The Master field is set to /microblaze_0 (Cached) . Leave it to this value so the accesses to the DDR3 memory are cached accesses. The Clock Connection (for unconnected clks) field is set to its default value of Auto .	Keep these default settings.
mig_7series_0 <ul style="list-style-type: none"> sys_rst 	The board interface reset will be connected to the reset pin of the Memory IP.	Keep the default setting.

4. After setting the appropriate options as shown in the table above, click **OK**.

At this point, your IP integrator diagram area should look like the following figure. The relative placement of your IP might be slightly different.

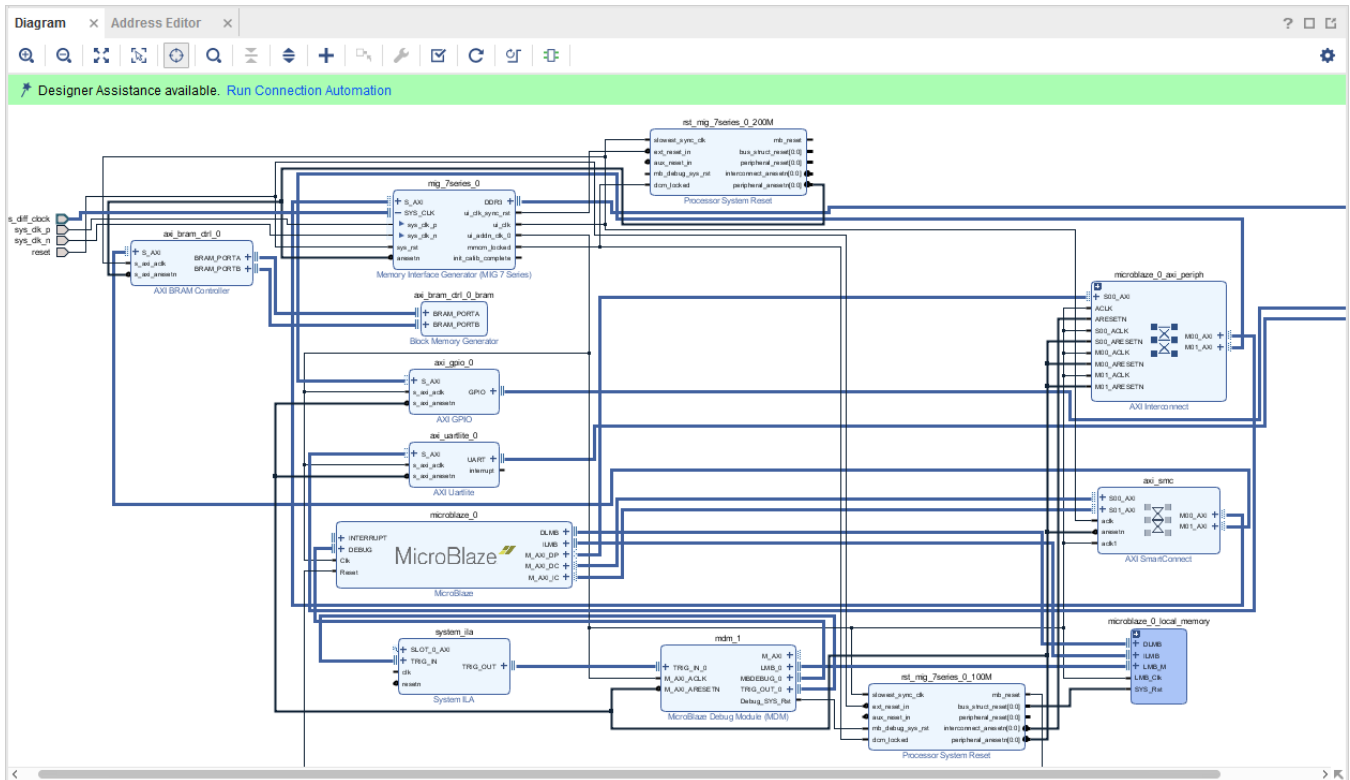

Figure 97: MicroBlaze Connected to UART, GPIO and AXI Timer

Mark Nets for Debugging

1. To monitor the AXI transactions taking place between the MicroBlaze and the GPIO, select the interface net connecting M01_AXI interface pin of the `microblaze_0_axi_periph` instance and the S_AXI interface pin of the `axi_gpio_0` instance.
2. Right-click and select **Debug** from the context menu.

Note: the Designer Assistance is available as indicated by the **Run Connection Automation** link in the banner of the block design.

3. Click the **Run Connection Automation** link.
4. In the Run Connection Automation dialog box, go with the default setting as shown.

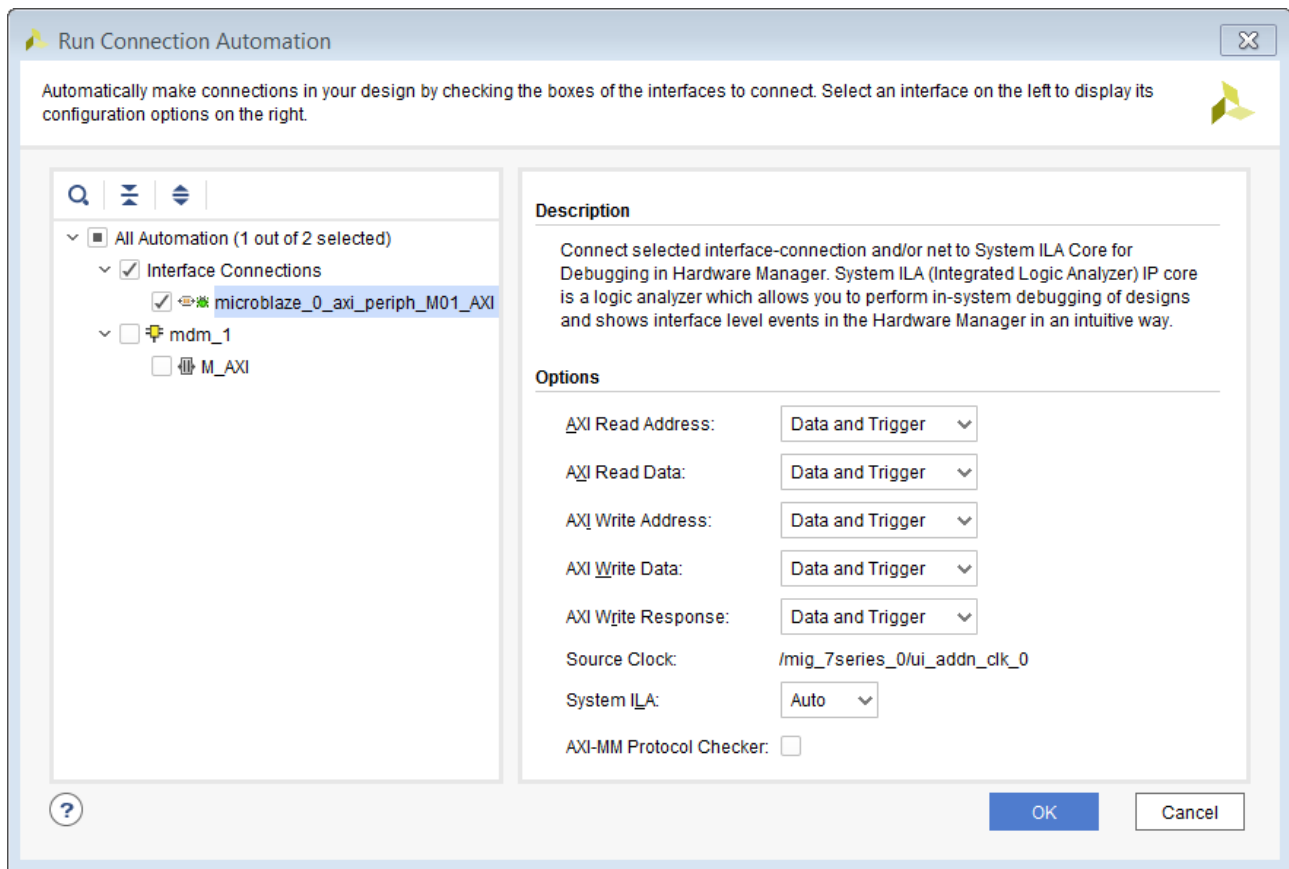

Figure 98: Dialog box for connecting `microblaze_0_axi_periph_M01_AXI` net to System ILA IP

5. Click **OK**.

- The cross-trigger pins of the MDM and the AXI Interface net connecting the `microblaze_0_axi_periph` Interconnect and `axi_gpio_0` are connected to the System ILA IP as shown.

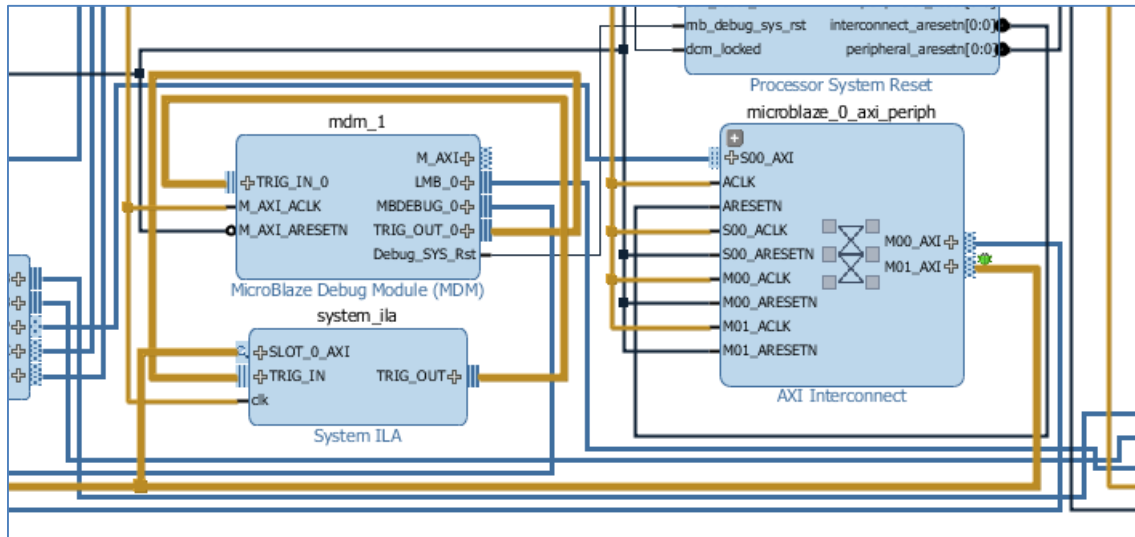



Figure 99: ILA connections to the Cross-Trigger Interface

- Click the **Regenerate Layout** button  in the IP Integrator toolbar to generate an optimum layout for the block design. The block diagram looks like Figure 100.

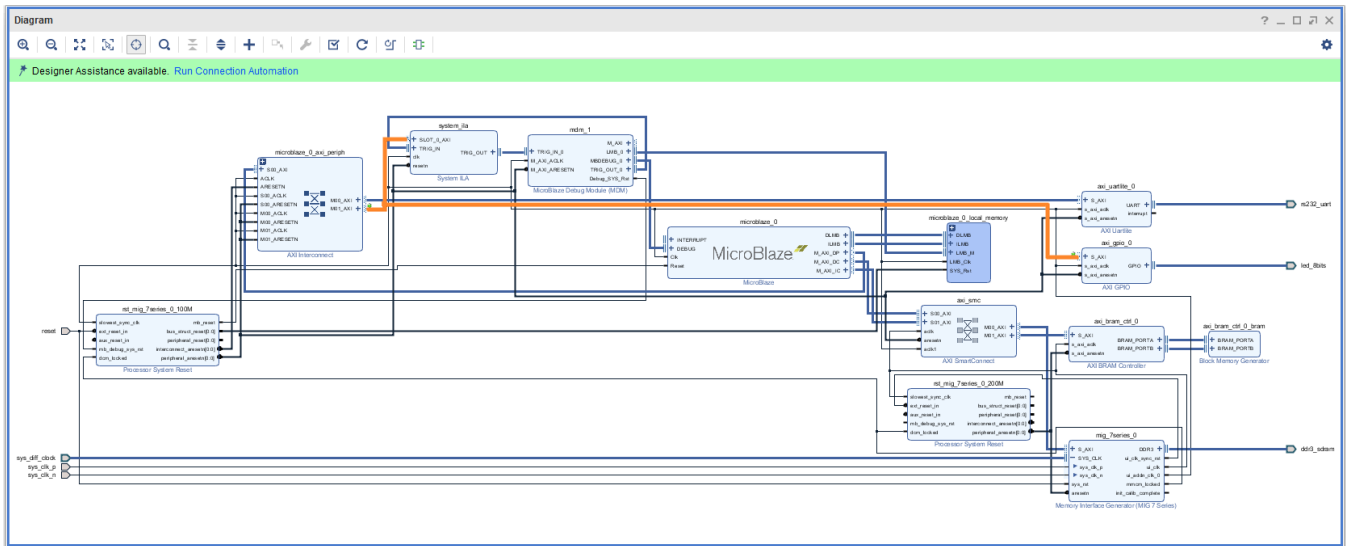



Figure 100: Block Diagram After Regenerating the Layout

Step 3: Memory-Mapping the Peripherals in IP Integrator

1. Click the **Address Editor** tab. In the Address Editor:
 - a. Expand the **microblaze_0** instance by clicking on the **Expand All** icon  in the toolbar to the top of the Address Editor window.
 - b. Change the range of **mig_7_series_0** IP in both the Data and the Instruction section to **512 MB**, as shown in [Figure 101](#).

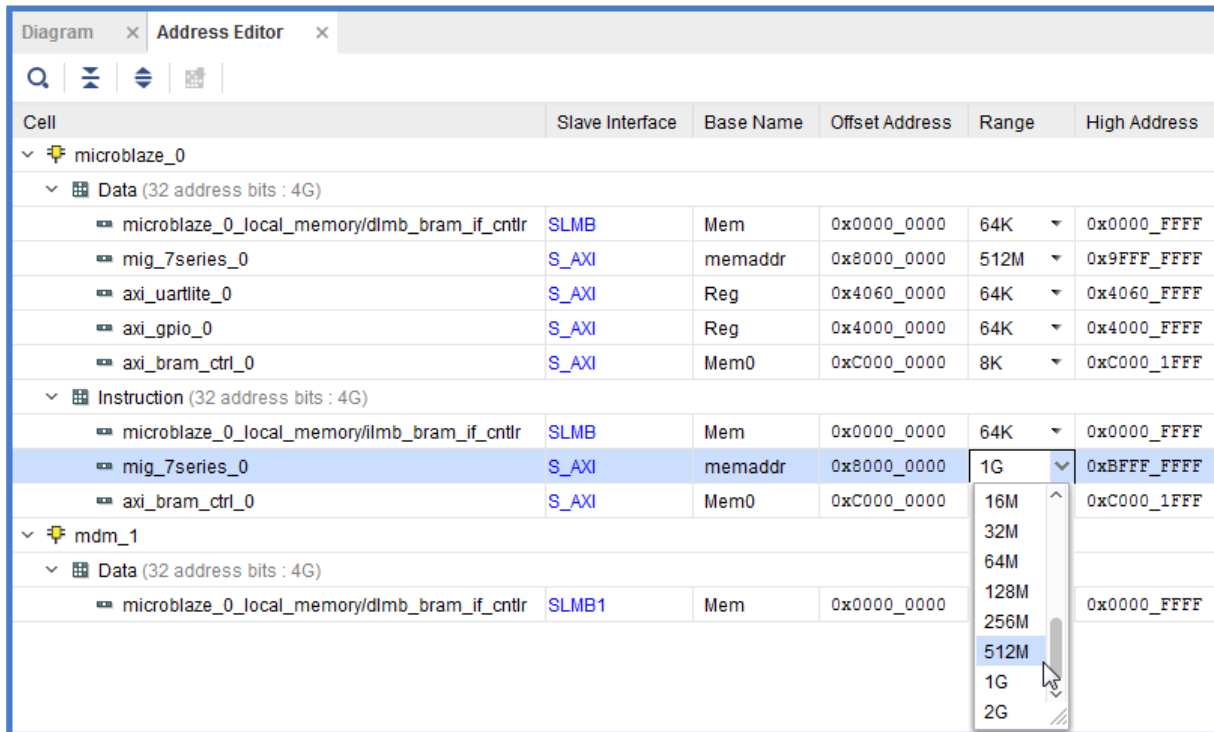

Figure 101: Data and Instruction Set to 512 MB

You must also ensure that the memory in which you are going to run and store your software is within the cacheable address range. This occurs when you enable Instruction Cache and Data Cache, while running the Block Automation for the MicroBlaze processor.

To use either Memory IP DDR or AXI block RAM, those IP must be in the cacheable area; otherwise, the MicroBlaze processor cannot read from or write to them.

You can also use this map to manually include or exclude IP from the cacheable region or otherwise specify their addresses. The following step demonstrates how to set the cacheable region.

2. Double click on the MicroBlaze in the block design to re-configure it. Go to the Cache page (page 3) of the **Re-customize IP** dialog box, as shown in Figure 102. On this page, for both the **Instruction Cache** and **Data Cache**:
 - a. The **Size in Bytes** option should be set to **32 kB**. Leave it set to this value.
 - b. Set the **Line length** option to **8**.
3. Set the **Base Address** to **0x8000000** by clicking the **Auto** button so that it changes to **Manual**, which enables the Base Address field.
4. Set the **High Address** to **0xFFFFFFFF** by clicking the **Auto** button so that it changes to **Manual**, which enables the High Address field.

5. Enable **Use Cache for All Memory Accesses** for both caches by clicking the Auto button first to change it to **Manual**, and then checking the check box.
6. Next, verify that the size of the cacheable segment of memory (that is, the memory space between the **Base** and **High** addresses of the **Instruction Cache** and **Data Cache**) is a power of **2**, which it should be if the options were set as specified. Additionally, ensure that the Base address and the High address of both Data Cache and Instruction Cache are the same.
7. Ensure that all IP that are slaves of the Instruction Cache, and that the Data Cache buses fall within this cacheable segment. Otherwise, the MicroBlaze processor cannot access those IP.

Note: For any IP connected only to the Instruction Cache and Data Cache bus, you must enable the **Use Cache for All Memory Access** option. In this example, the Instruction Cache and Data Cache buses are the sole masters of DDR and block RAM; therefore, you must enable this option. In other configurations, you must decide whether to enable this option per the design requirements.

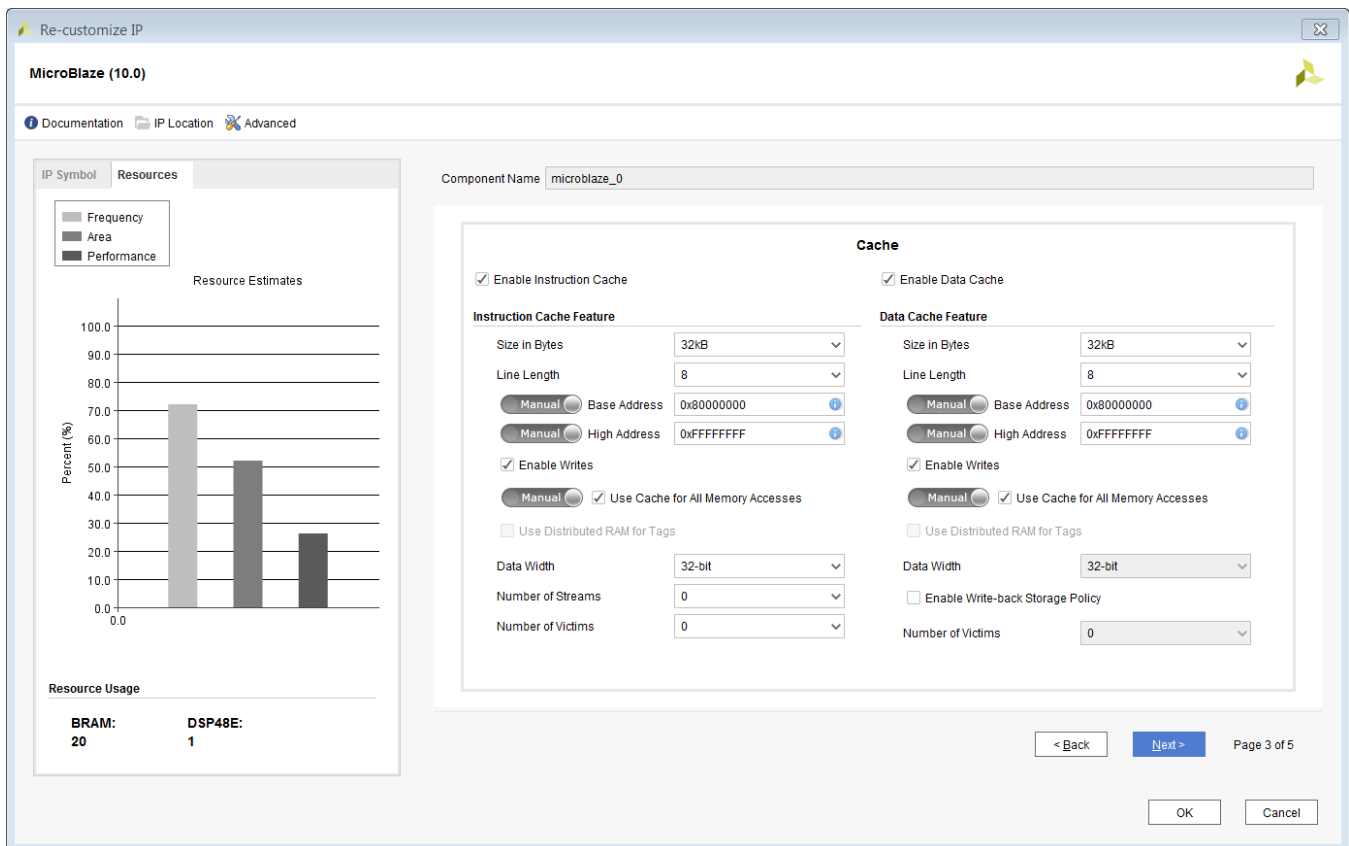



Figure 102: Setting Cache option for MicroBlaze

8. Click **OK**.

Step 4: Validate Block Design

To run design rule checks on the design:

1. Click the **Validate Design** button  on the toolbar, or select **Tools > Validate Design**.
2. The Validate Design dialog box informs you that there are no critical warnings or errors in the design. Click **OK**.
3. Save your design by pressing **Ctrl+S**, or select **File > Save Block Design**.

Step 5: Generate Output Products

1. In the Sources window, select the block design, then right-click it and select **Generate Output Products**. Alternatively, you can click **Generate Block Design** in the Flow Navigator.

The Generate Output Products dialog box opens.

2. Click **Generate**.

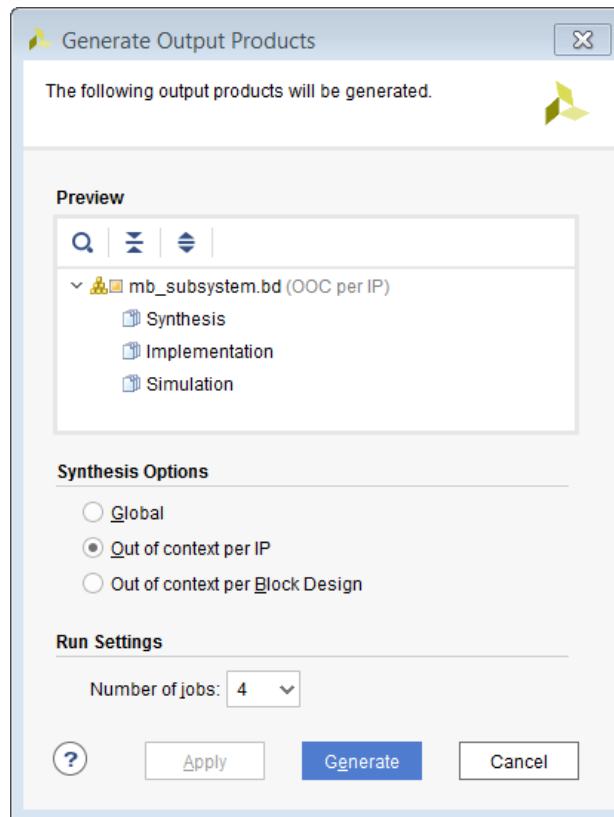
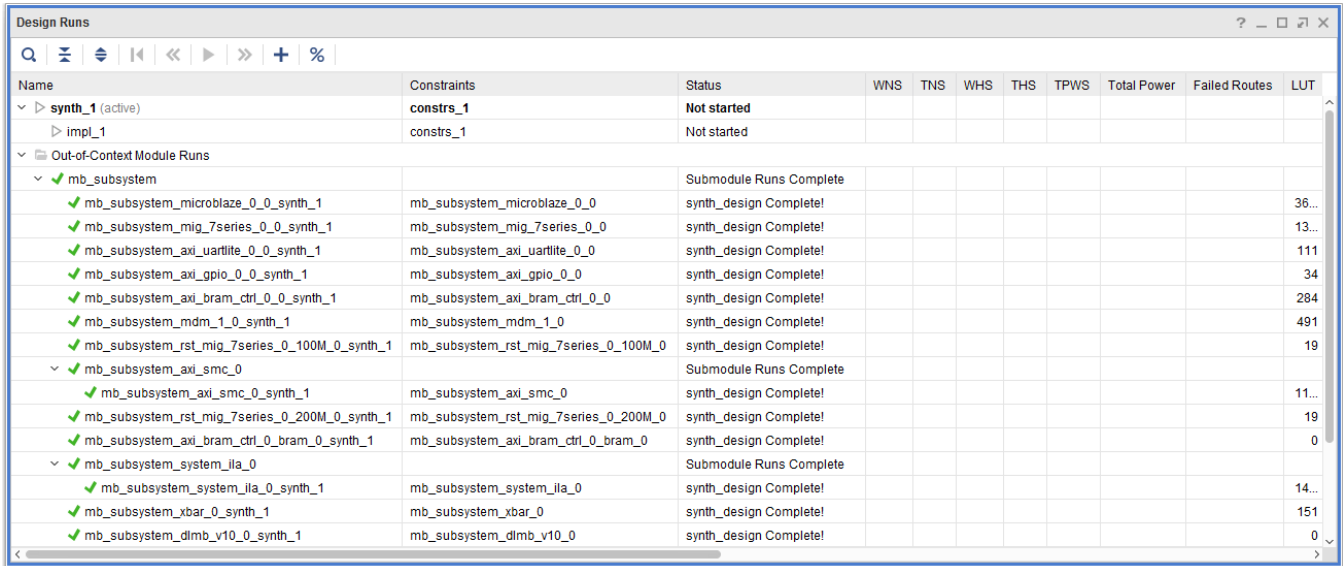

Figure 103: Generate Output Dialog Box

The Generate Output Products dialog box informs you that Out-of-context module runs were launched.

3. Click **OK**.
4. Wait a few minutes for all the Out-of-Context module runs to finish as shown in the Design Runs windows.



Name	Constraints	Status	WNS	TNS	WHS	THS	TPWS	Total Power	Failed Routes	LUT
synth_1 (active)	constrs_1	Not started								
impl_1	constrs_1	Not started								
Out-of-Context Module Runs										
mb_subsystem		Submodule Runs Complete								
mb_subsystem_microblaze_0_0_synth_1	mb_subsystem_microblaze_0_0	synth_design Complete!								36...
mb_subsystem_mig_7series_0_0_synth_1	mb_subsystem_mig_7series_0_0	synth_design Complete!								13...
mb_subsystem_axi_uartlite_0_0_synth_1	mb_subsystem_axi_uartlite_0_0	synth_design Complete!								111
mb_subsystem_axi_gpio_0_0_synth_1	mb_subsystem_axi_gpio_0_0	synth_design Complete!								34
mb_subsystem_axi_bram_ctrl_0_0_synth_1	mb_subsystem_axi_bram_ctrl_0_0	synth_design Complete!								284
mb_subsystem_mdm_1_0_synth_1	mb_subsystem_mdm_1_0	synth_design Complete!								491
mb_subsystem_rst_mig_7series_0_100M_0_synth_1	mb_subsystem_rst_mig_7series_0_100M_0	synth_design Complete!								19
mb_subsystem_axi_smc_0		Submodule Runs Complete								
mb_subsystem_axi_smc_0_synth_1	mb_subsystem_axi_smc_0	synth_design Complete!								11...
mb_subsystem_rst_mig_7series_0_200M_0_synth_1	mb_subsystem_rst_mig_7series_0_200M_0	synth_design Complete!								19
mb_subsystem_axi_bram_ctrl_0_bram_0_synth_1	mb_subsystem_axi_bram_ctrl_0_bram_0	synth_design Complete!								0
mb_subsystem_system_ila_0		Submodule Runs Complete								
mb_subsystem_system_ila_0_synth_1	mb_subsystem_system_ila_0	synth_design Complete!								14...
mb_subsystem_xbar_0_synth_1	mb_subsystem_xbar_0	synth_design Complete!								151
mb_subsystem_dlmb_v10_0_synth_1	mb_subsystem_dlmb_v10_0	synth_design Complete!								0

Figure 104: Design Runs Windows Showing Status of Out-of-Context Module Runs

Step 6: Create a Top-Level Verilog Wrapper

1. Under Design Sources, right-click the block `design_mb_subsystem` and click **Create HDL Wrapper**.

In the Create HDL Wrapper dialog box, **Let Vivado manage wrapper and auto-update** is selected by default.

2. Click **OK**.

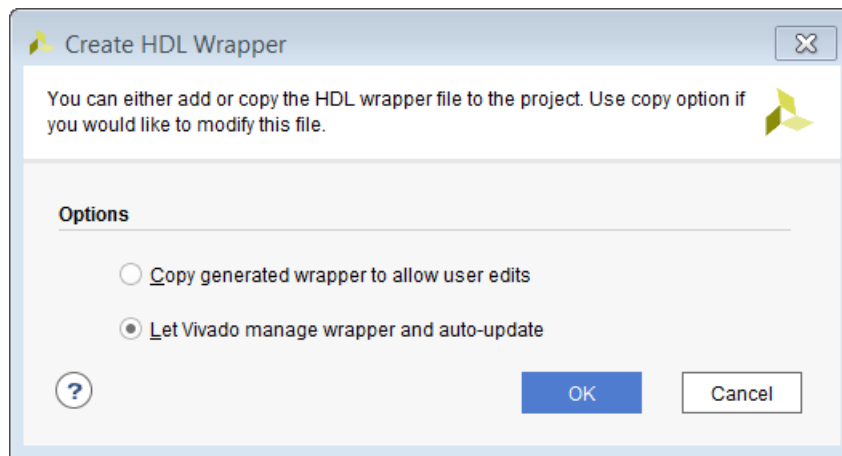

Figure 105: Creating an HDL Wrapper

Step 7: Take the Design through Implementation

In the Flow Navigator:

1. Click **Generate Bitstream**. No implementation Results Available dialog box opens.
2. Click **Yes**.
3. The Launch Runs dialog box opens. Make the appropriate choices and click **OK**.

Bitstream generation can take several minutes to complete. Once it finishes, the Bitstream Generation Completed dialog box asks you to select what to do next.

4. Keep the default selection of **Open Implemented Design** and click **OK**.
5. Verify that all timing constraints have been met by looking at the Timing - Timing Summary window, as shown in Figure 106.

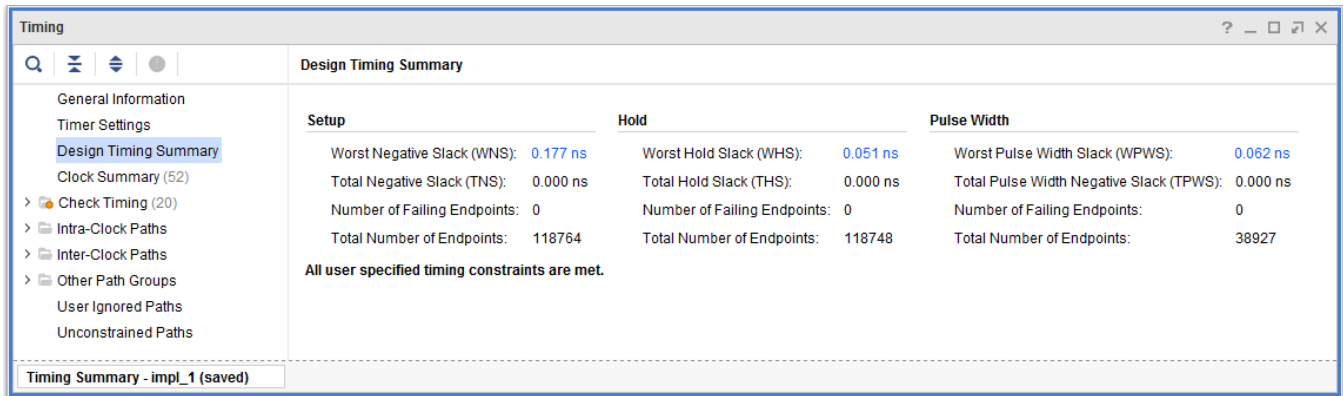

Figure 106: Timing Summary

Step 8: Exporting the Design to SDK

Next, open the design and export to SDK.

1. Select **File > Export > Export Hardware**.
2. In the Export to Hardware dialog box, select the **Include bitstream** check box, shown in the following figure. Make sure that the **Export to** field is set to **<Local to Project>**.

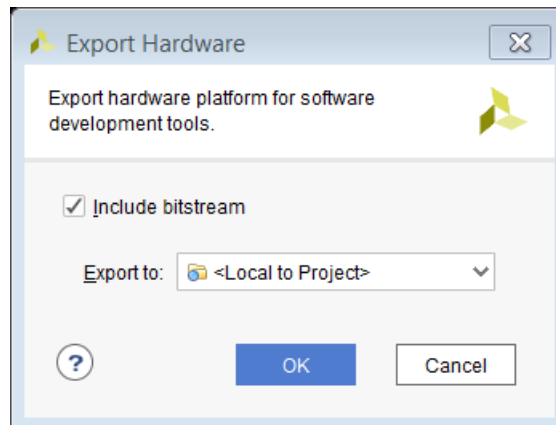

Figure 107: Export to Hardware Dialog Box

3. Click **OK**.

4. Select **File > Launch SDK**. In the Launch SDK dialog box, shown in the following figure, make sure that both the **Exported location** and the **Workspace** drop-down lists are set to **<Local to Project>**.

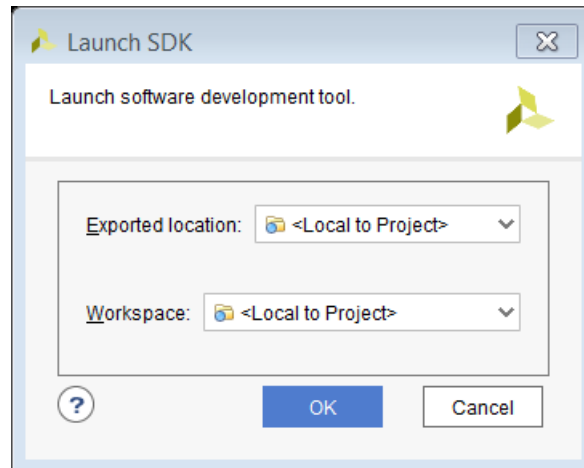

Figure 108: Launch SDK Dialog Box

5. Click **OK**.
SDK launches in a separate window.

Step 9: Create a “Peripheral Test” Application

1. In SDK, right-click **mb_subsystem_wrapper_hw_platform_0** in the Project Explorer and select **New > Project**, as shown in the following figure:

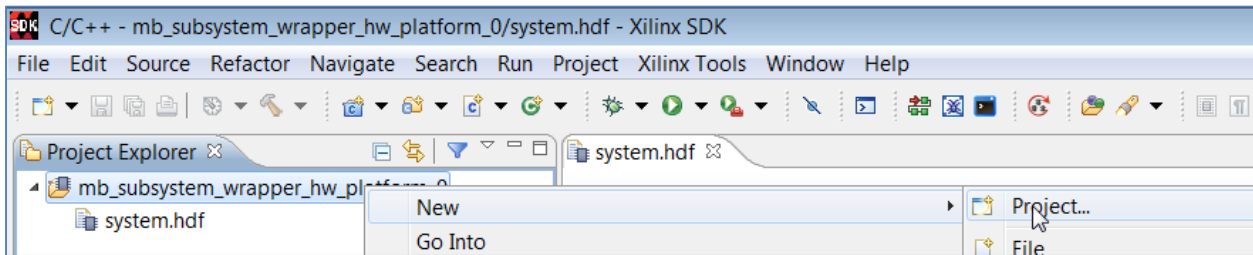

Figure 109: SDK New Project Selection

2. In the New Project dialog box, shown in the following figure, select **Xilinx > Application Project**.

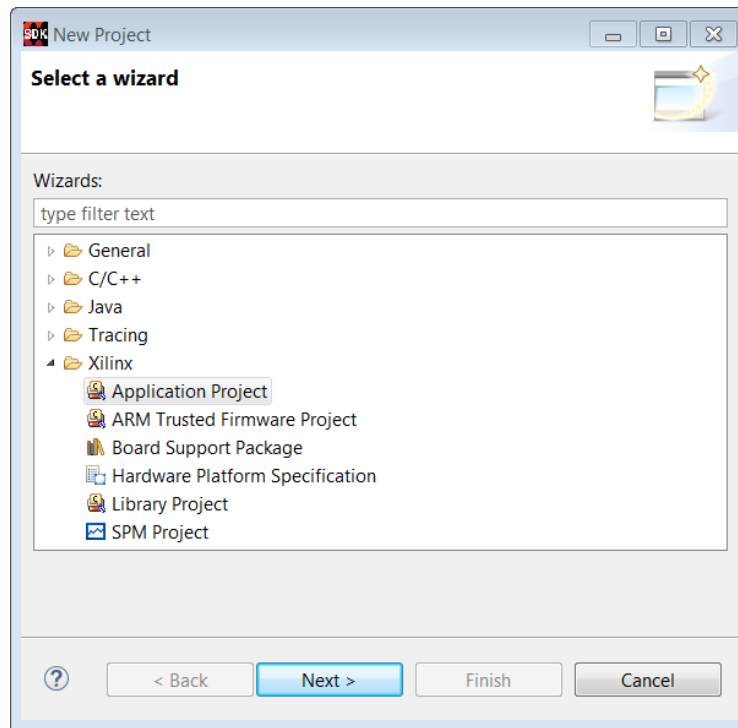

Figure 110: SDK New Project Wizard

3. Click **Next**.
4. Type a name (such as `peri_test`) for your project and choose standalone as the OS platform, as displayed in Figure 111.

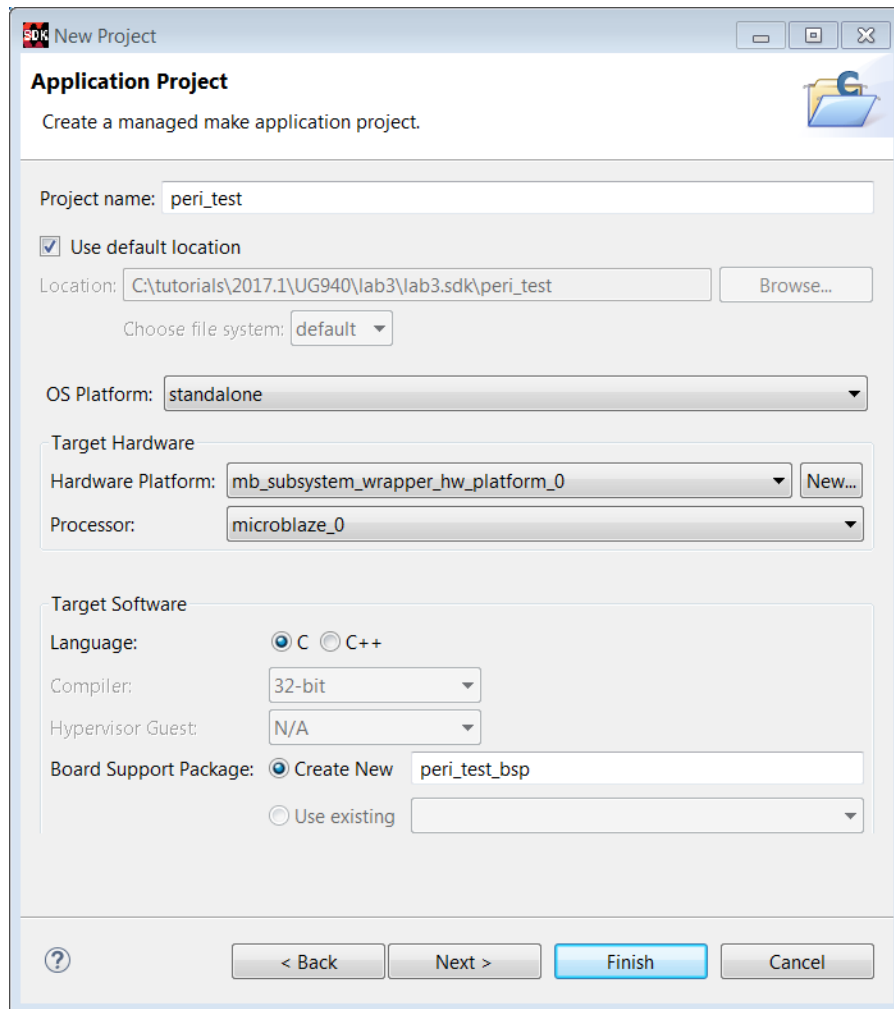

Figure 111: New Project: Application Project Wizard

5. Click **Next**.

6. Select the **Peripheral Tests** application template, shown in the following figure, and click **Finish**.

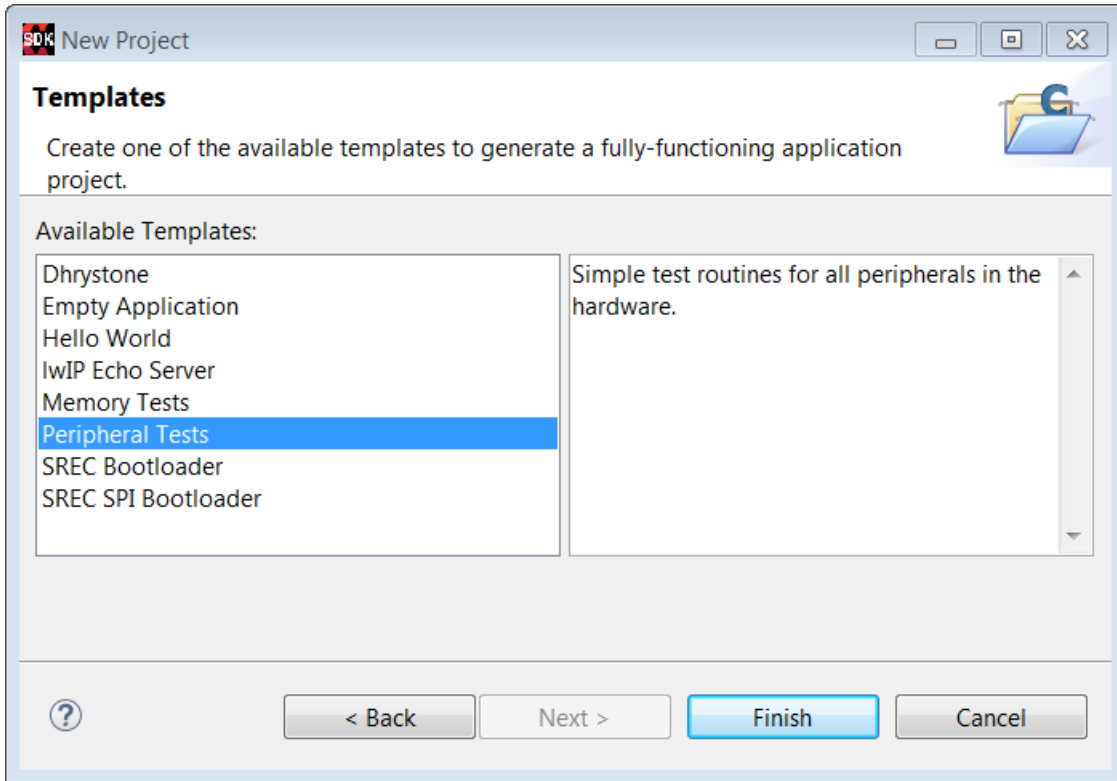

Figure 112: New Project: Template Wizard

SDK creates a new “peri_test” application.

7. Right-click the `peri_test` application in the Project Explorer and select **Generate Linker Script**. The Generate Linker Script dialog box opens, as shown in Figure 113.

- Select the Basic tab and change the **Assigned Memory for Heap and Stack** to mig_7series_0.

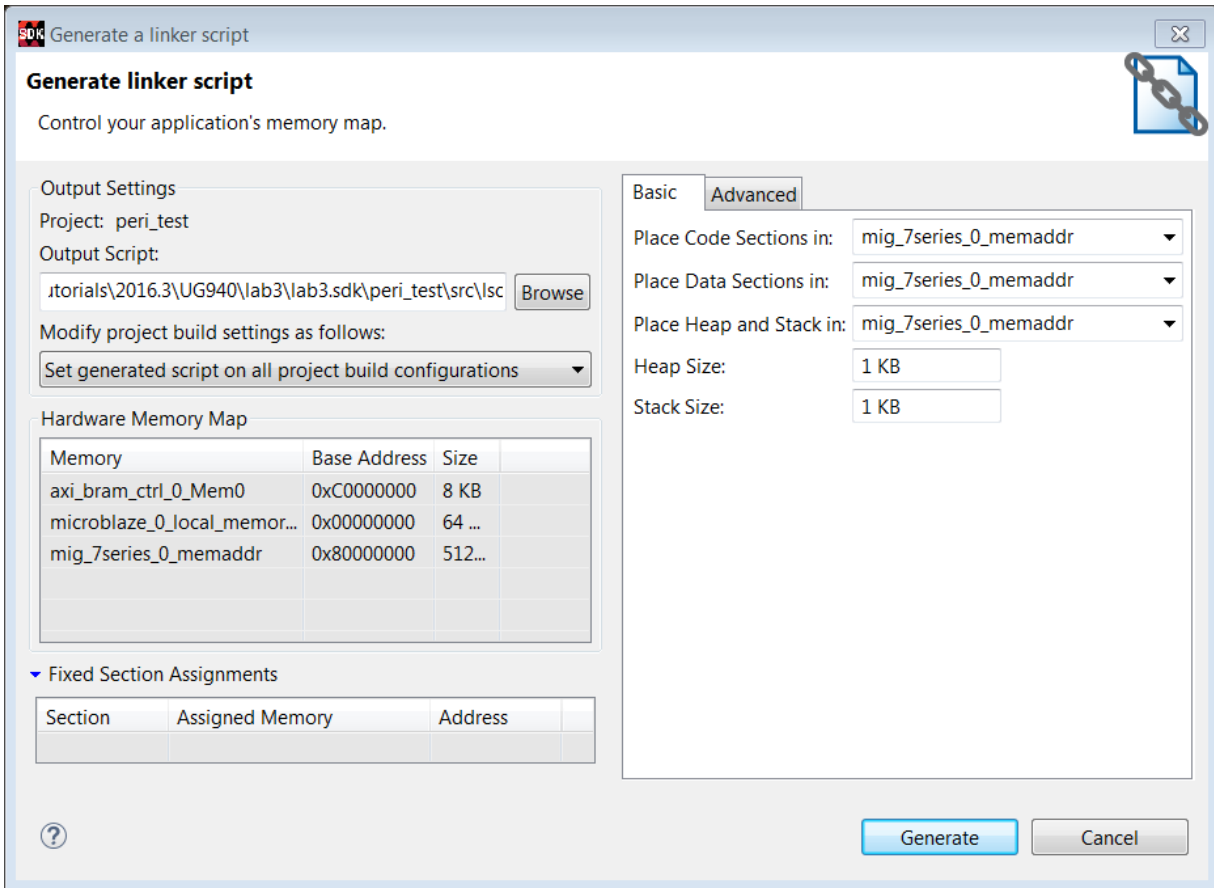

Figure 113: Basic Tab of the Generate a Linker Script Dialog Box

9. The Advanced options all change to **mig_7_series_0** as shown below.

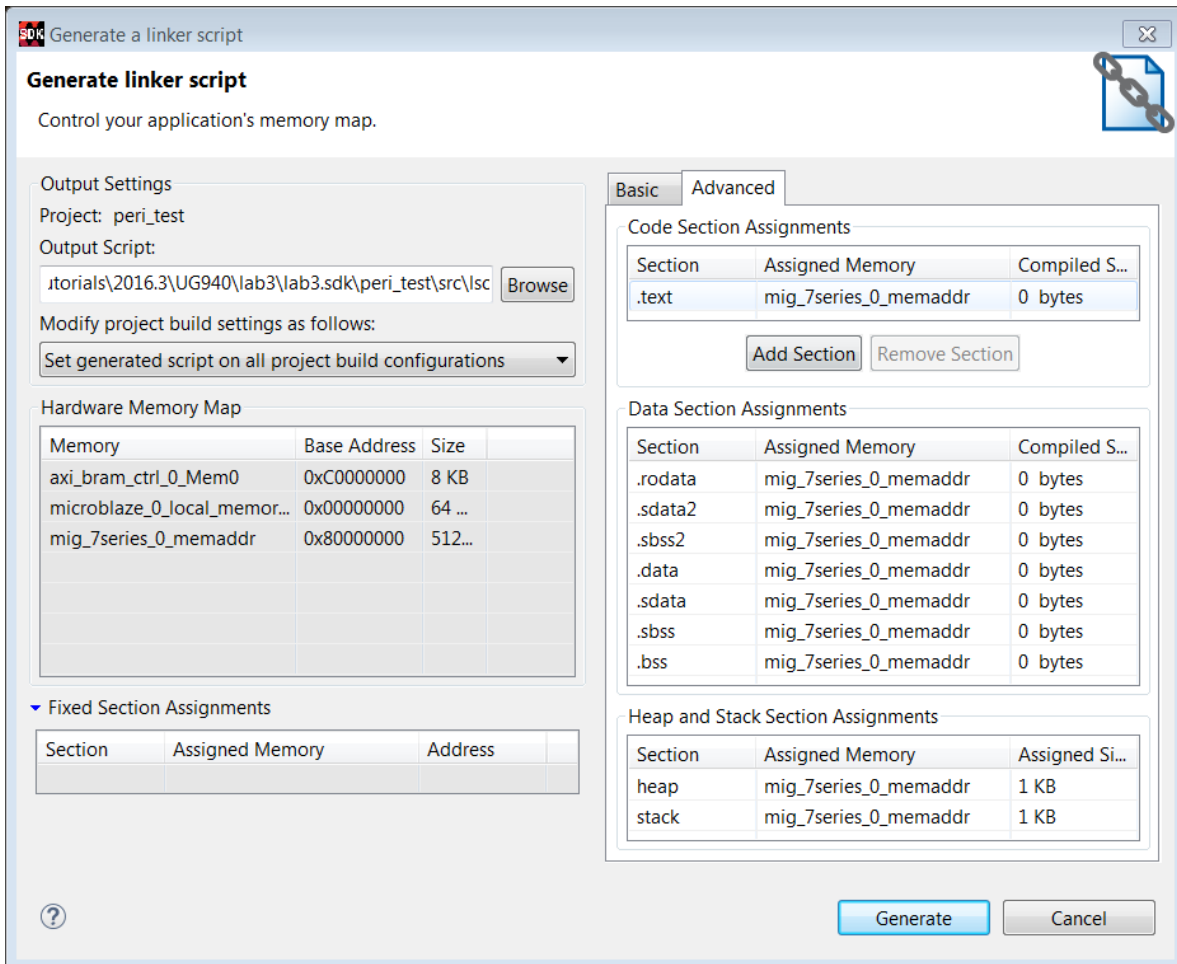

Figure 114: Generate Linker Script Dialog Box

Setting these values to mig_7series_0 ensures that the compiled code executes from the Memory IP.

10. Click **Generate**.
11. Click **Yes** to overwrite it in the Linker Script Already Exists! dialog box.

Step 10: Executing the Software Application on a KC705 Board

Make sure that you have connected the target board to the host computer and it is turned on.

1. Select **Xilinx Tools > Program FPGA** to open the Program FPGA dialog box. In the Program FPGA dialog box, click **Program**, as shown in the following figure:

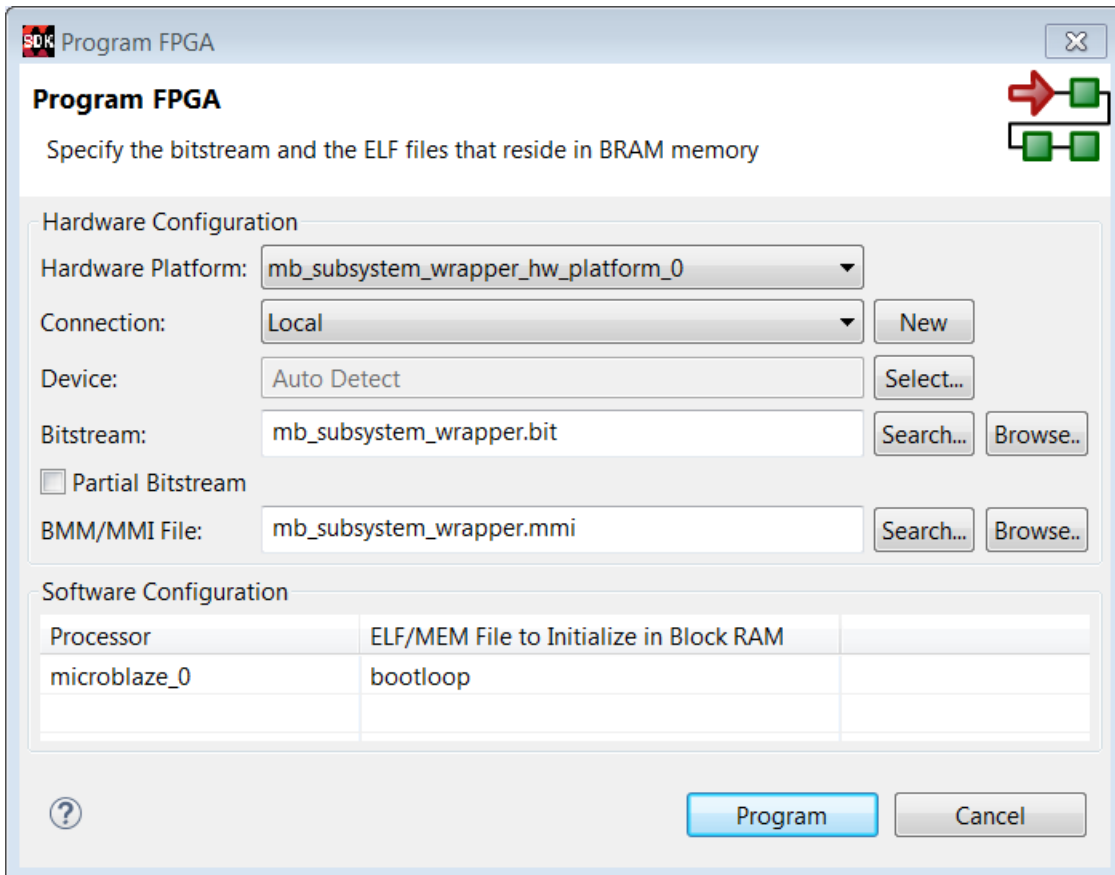

Figure 115: Program FPGA Dialog Box

2. Select and right-click the **peri_test** application in the Project Explorer, and select **Debug As > Debug Configurations**.

The Debug Configurations dialog box opens, as shown in the following figure.

3. Right-click **Xilinx C/C++ application (System Debugger)**, and select **New**.

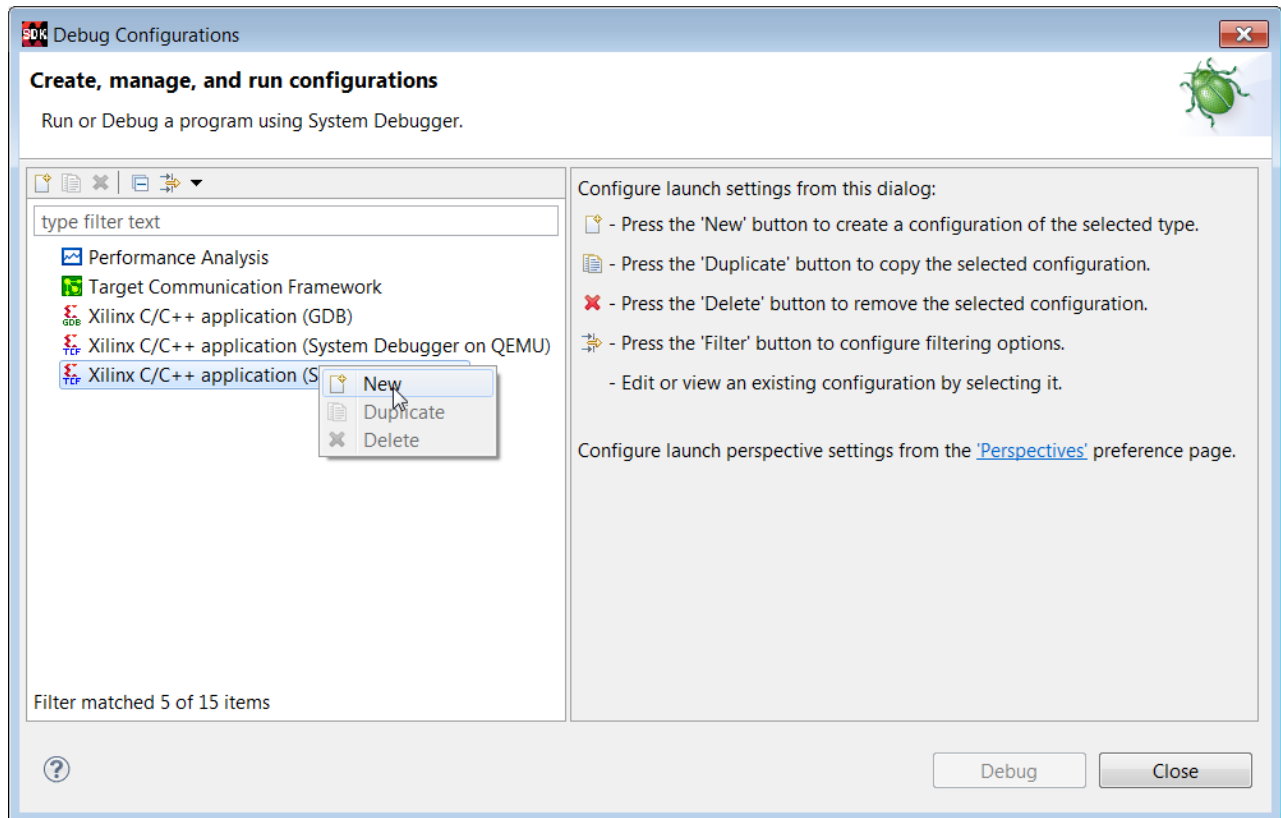

Figure 116: Create New Debug Configuration

4. Click **Debug**.

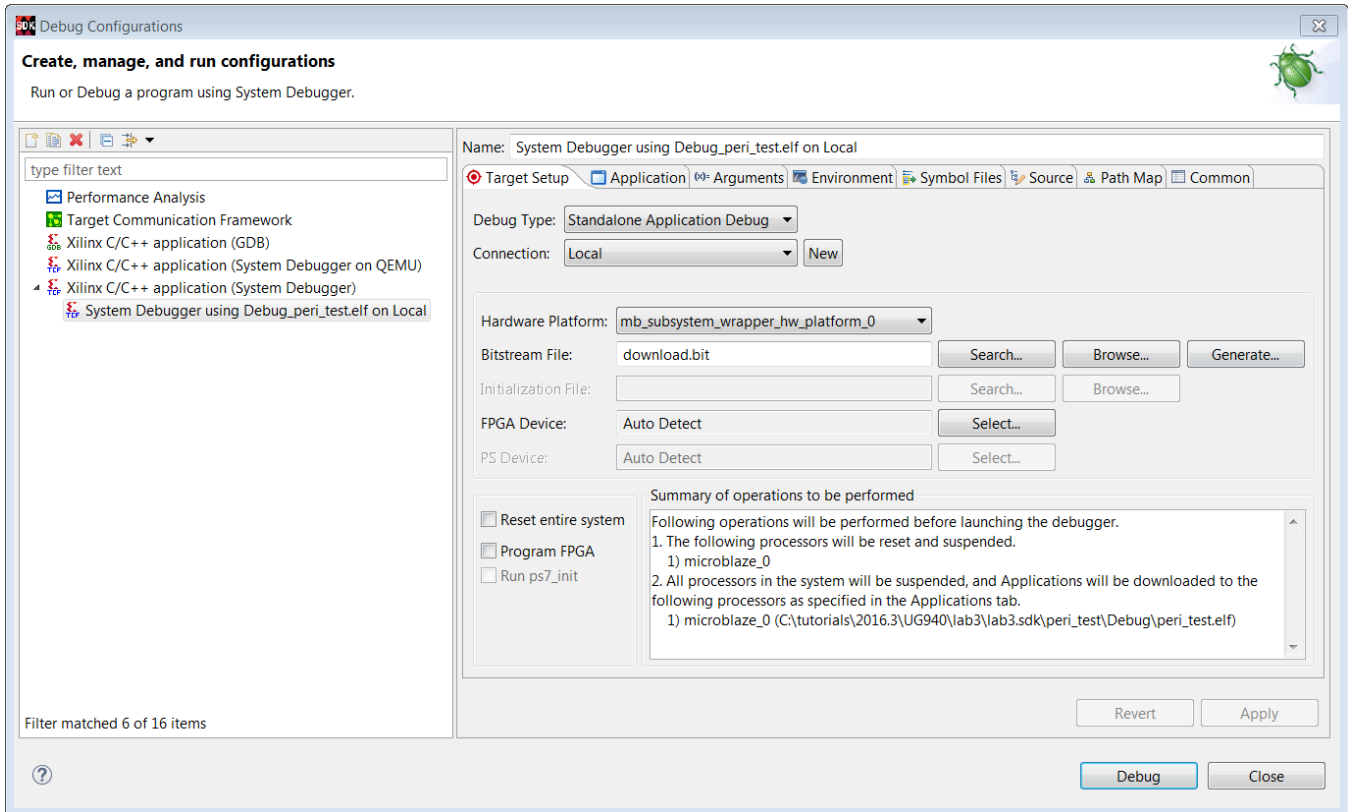

Figure 117: Debug Configurations dialog box

The Confirm Perspective Switch dialog box opens.

5. Click **Yes** to confirm the perspective switch.

The Debug perspective window opens.

6. Set the terminal by selecting the **SDK Terminal** tab and clicking the  button.

7. Use the settings shown in Figure 118 for the KC705 board and click **OK**.

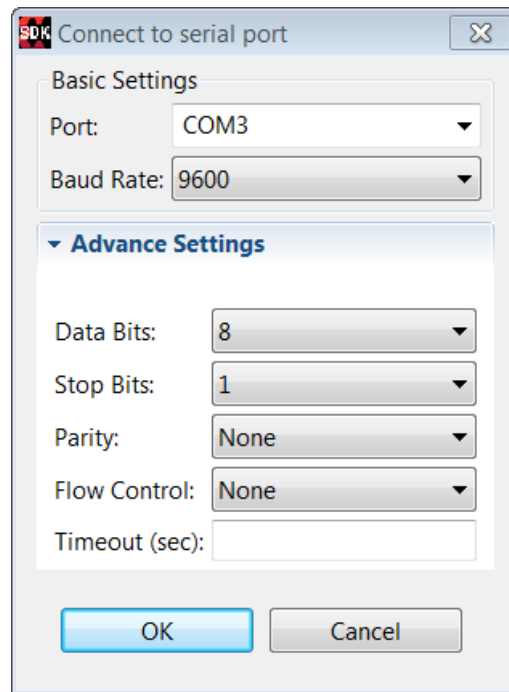

Figure 118: Terminal Settings

- Verify the Terminal connection by checking the status at the top of the tab as shown in the following figure:

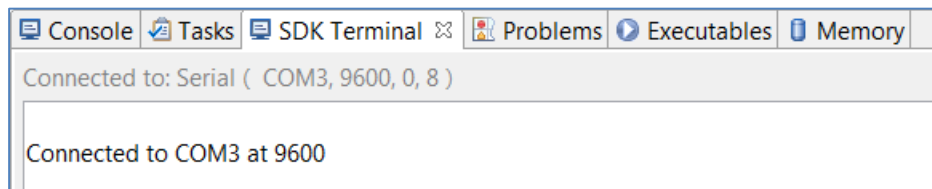
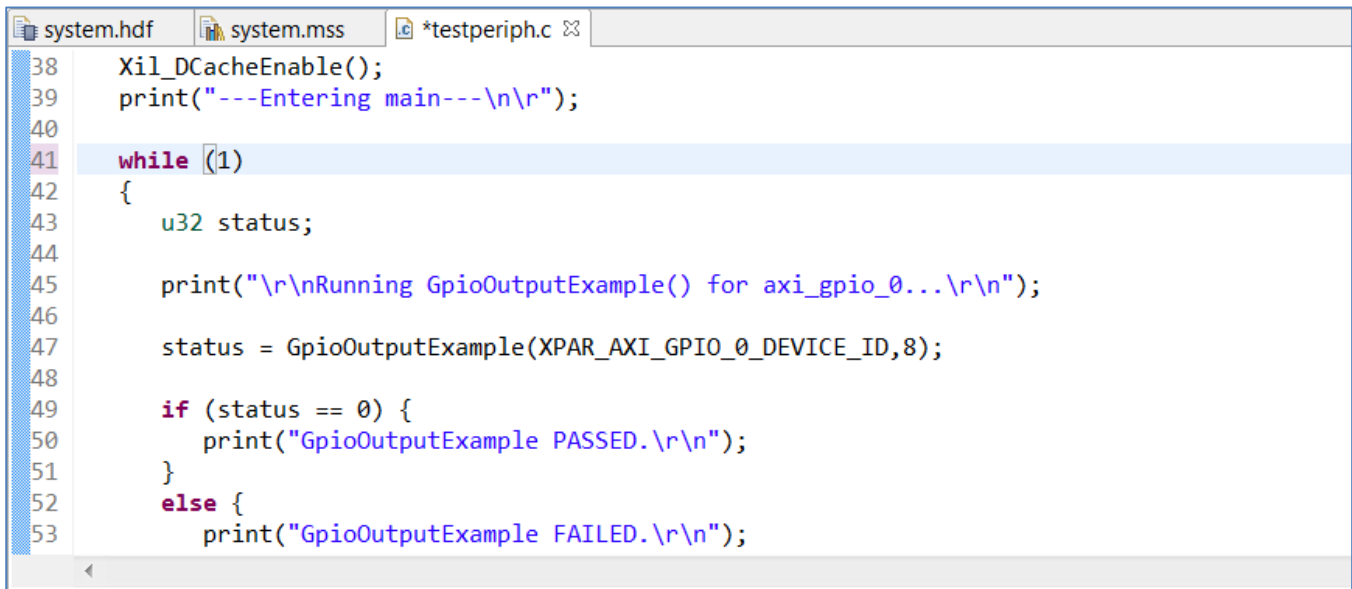

Figure 119: Verify Terminal Connection

- If it is not already open, select `../src/testperiph.c`, and double click to open the source file.

10. Modify the source file by inserting a while statement at approximately line 41.
 - a. Click the blue bar on the left side of the `testperiph.c` window as shown in the figure and select **Show Line Numbers**.
 - b. In line 41, add `while (1)` above in front of the curly brace as shown in the following figure:



```

system.hdf | system.mss | *testperiph.c
38  Xil_DCacheEnable();
39  print("---Entering main---\n\r");
40
41  while (1)
42  {
43      u32 status;
44
45      print("\r\nRunning GpioOutputExample() for axi_gpio_0...\r\n");
46
47      status = GpioOutputExample(XPAR_AXI_GPIO_0_DEVICE_ID,8);
48
49      if (status == 0) {
50          print("GpioOutputExample PASSED.\r\n");
51      }
52      else {
53          print("GpioOutputExample FAILED.\r\n");

```

Figure 120: Modify testperiph.c

11. Add a breakpoint in the code so that the processor stops code execution when the breakpoint is encountered. To do so, scroll down to line 50 and double-click on the left pane, which adds a breakpoint on that line of code, as shown in Figure 121.
12. Click **Ctrl + S** to save the file. Alternatively, you can select **File > Save**.

```

system.hdf | system.mss | *testperiph.c
38  Xil_DCacheEnable();
39  print("---Entering main---\n\n");
40
41  while (1)
42  {
43      u32 status;
44
45      print("\n\nRunning GpioOutputExample() for axi_gpio_0...\n\n");
46
47      status = GpioOutputExample(XPAR_AXI_GPIO_0_DEVICE_ID,8);
48
49      if (status == 0) {
50          print("GpioOutputExample PASSED.\n\n");
51      }
52      else {
53          print("GpioOutputExample FAILED.\n\n");

```

Figure 121: Set a Breakpoint

Now you are ready to execute the code from SDK.

Step 11: Connect to Vivado Logic Analyzer

Connect to the KC705 board using the Vivado Logic Analyzer.

1. In the Vivado IDE session, from the **Program and Debug** drop-down list of the Vivado Flow Navigator, select **Open Hardware Manager**.
2. In the Hardware Manager window, click **Open target > Open New Target**.

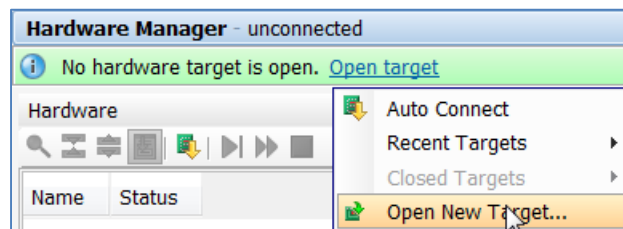

Figure 122: Open a New Hardware Target

Note: You can also use the Auto Connect option to connect to the target hardware.

The Open New Hardware Target dialog box opens, shown in Figure 123.

3. Click **Next**.

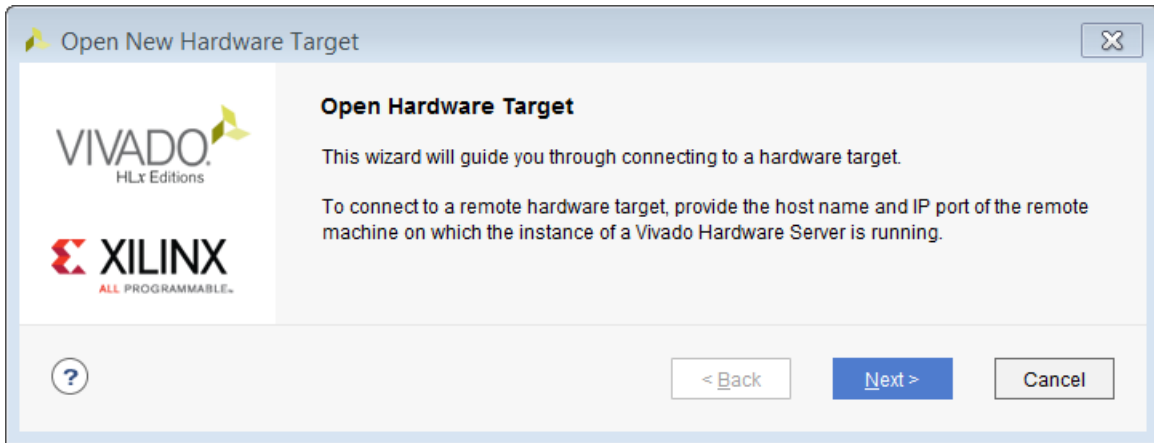

Figure 123: Open Hardware Target

On the Hardware Server Settings page, ensure that the Connect to field is set to **Local server (target is on local machine)**, as shown in the following figure:

4. Click **Next**.

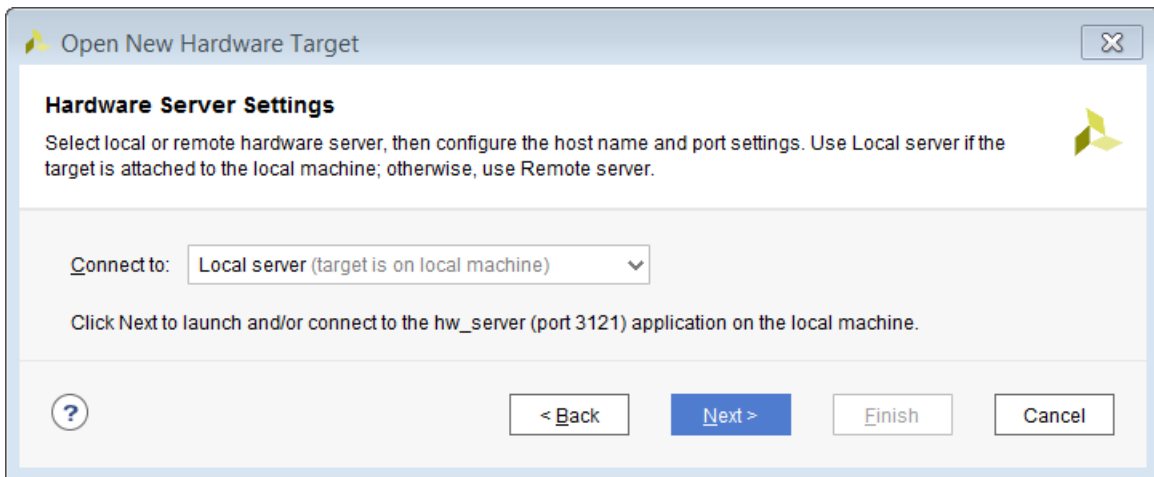

Figure 124: Specify Server Name

- On the Select Hardware Target page, shown below, click **Next**.

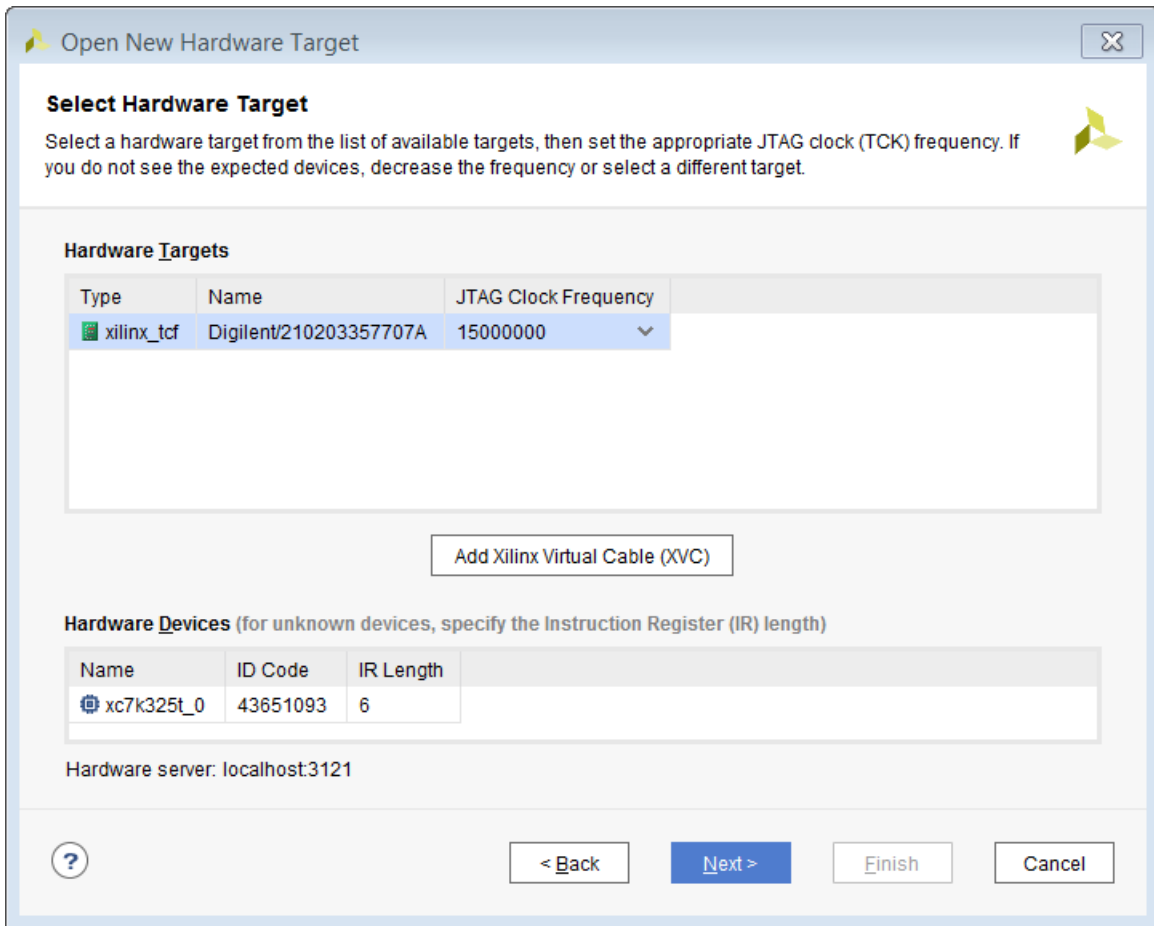

Figure 125: Select Hardware Target

- Ensure that all the settings are correct on the Open Hardware Target Summary dialog box and click **Finish**.

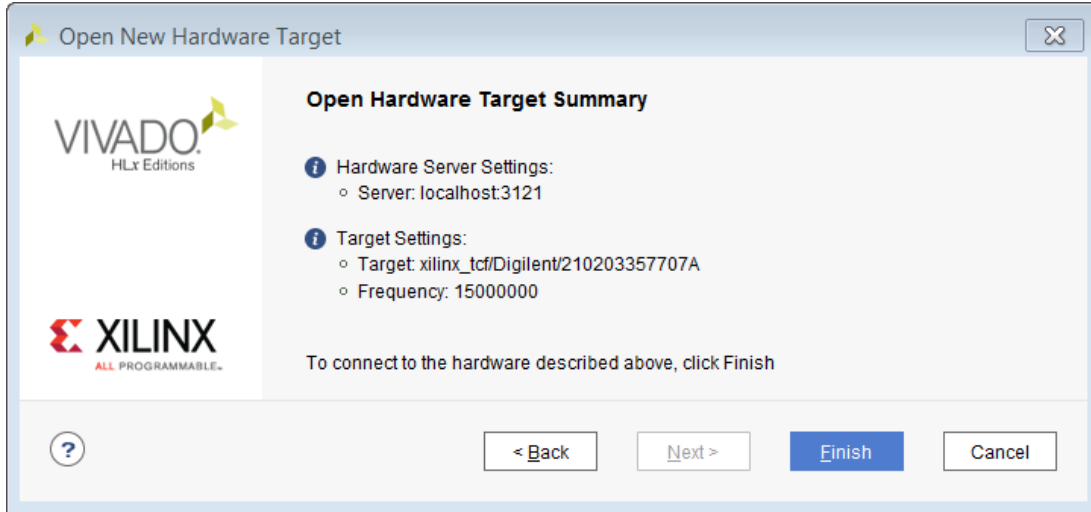

Figure 126: Open Hardware Target Summary

Step 12: Setting the MicroBlaze to Logic Cross Trigger

When the Vivado Hardware Session successfully connects to the ZC702 board, you see the information shown in the following figure:

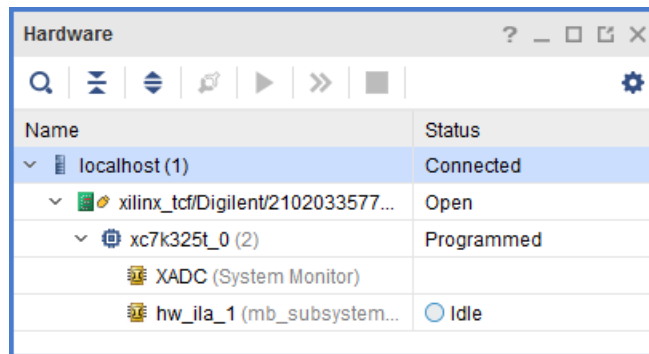

Figure 127: Vivado Hardware Window

1. Select the Settings - hw_ila_1 tab and set the **Trigger Mode Settings** as follows:
 - Set **Trigger** mode to **TRIG_IN_ONLY**
 - Set **TRIG_OUT** mode to **TRIG_IN_ONLY**
 - Under **Capture Mode Settings**, change Trigger position in window to **512**.

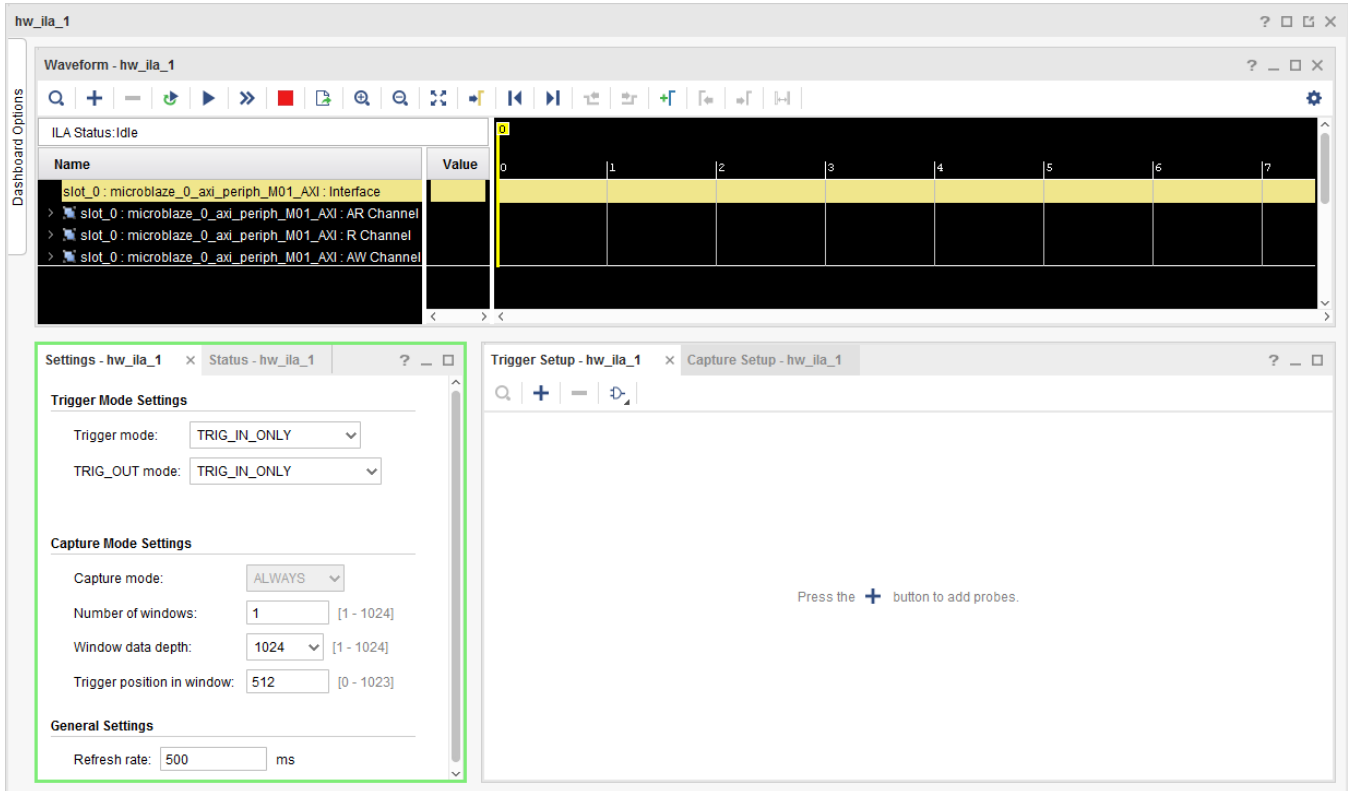



Figure 128: Set ILA Properties for hw_ila_1

2. Arm the ILA core by clicking the **Run Trigger** button . This arms the ILA and you should see the status "Waiting for Trigger" as shown in Figure 129.

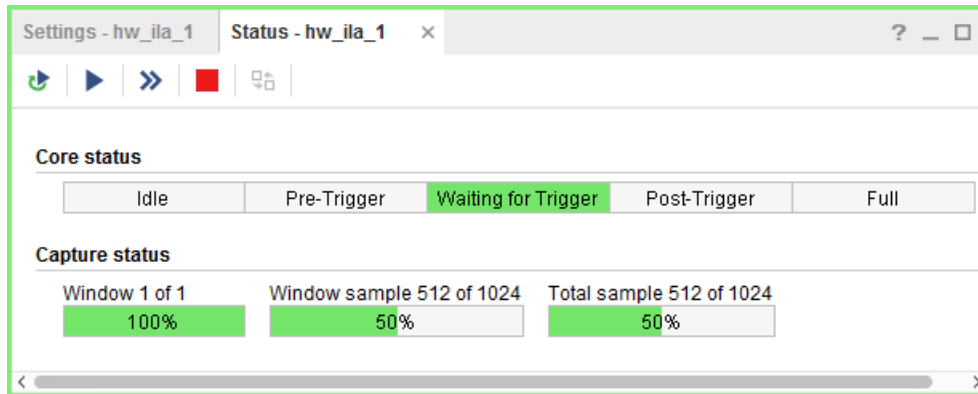



Figure 129: Armed ILA Core

- In SDK, in the Debug window, click the **MicroBlaze #0** in the Debug window and click the **Resume** button . The code will execute until the breakpoint set on Line 50 in `testperiph.c` file is reached. As the breakpoint is reached, this triggers the ILA, as seen in the following figure:

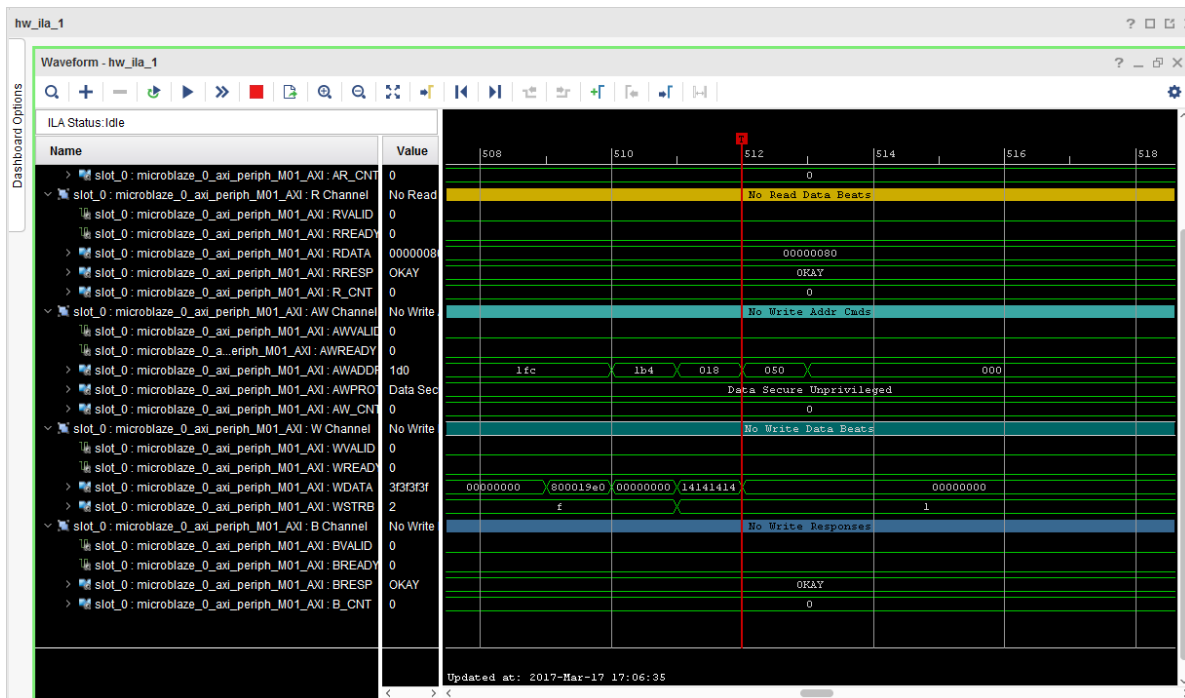

Figure 130: MicroBlaze to Logic Cross Trigger Waveform in hw_ila_1

This demonstrates that when the breakpoint is encountered during code execution, the MicroBlaze triggers the ILA that is set up to trigger. This way you can monitor the state of the hardware at a certain point of code execution.

Step 13: Setting the Logic to Processor Cross-Trigger

Now try the logic to processor side of the cross-trigger mechanism. In other words, remove the breakpoint that you set earlier on line 50 to have the ILA trigger the processor and stop code execution. To do this:

1. Select the Breakpoints tab towards the top right corner of SDK window, and uncheck the `testperiph.c` [line: 50] checkbox. This removes the breakpoint that you set up earlier.

Note: Alternatively, you can also click on the breakpoint in the `testperiph.c` file and select **Disable Breakpoint**.

2. In the Debug window, right-click the **MicroBlaze #0 target** and select **Resume**. The code runs continuously because it has an infinite loop.

You can see the code executing in the Terminal Window in SDK.

3. In Vivado, select the Settings - `hw_ila_1` tab. Change the Trigger Mode to **BASIC_OR_TRIG_IN** and the `TRIG_OUT` mode to **TRIGGER_OR_TRIG_IN**.
4. Click on the + sign in the Trigger Setup window to add the `slot_0:microblaze_0_axi_periph_M01:AWVALID` signal from the Add Probes window.
5. In the Basic Trigger Setup window, for `slot_0:microblaze_0_axi_periph_M01:AWVALID` signal, ensure that the **Radix** field is set to **[B] (Binary)** and set the **Value** field to **1**. This essentially sets up the ILA to trigger when the `awvalid` transitions to a value of 1.
6. Click the **Run Trigger** button to “arm” the ILA in the Status – `hw_ila_1` window. The ILA immediately triggers as the application software is continuously performing a write to the GPIO thereby toggling the `net_slot_0_axi_awvalid` signal, which causes the ILA to trigger. The ILA in turn, toggles the `TRIG_OUT` signal, which signals the processor to stop code execution.

This is seen in SDK the in the highlighted area of the debug window.

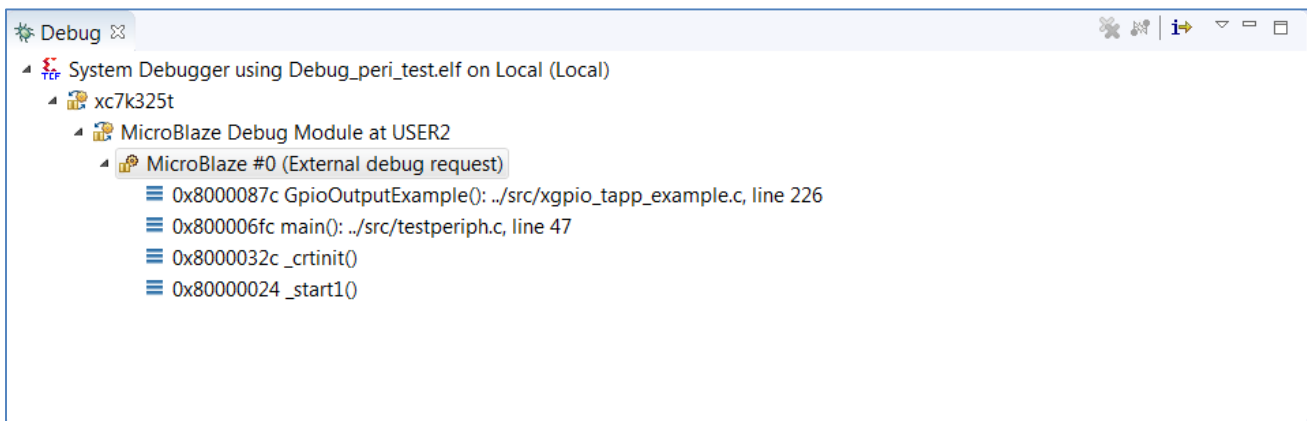

Figure 131: Verify that the Processor Has Been Interrupted in SDK

Conclusion

In this tutorial, you:

- Stitched together a design in the Vivado IP integrator tool
 - Took the design through implementation and bitstream generation
 - Exported the hardware to SDK
 - Created and modified application code that runs on a Standalone Operating System
 - Modified the linker script so that the code executes from the DDR3
 - Verified cross-trigger functionality between the MicroBlaze processor executing code and the design logic
-

Lab Files

The Tcl script `lab3.tcl` is included with the design files to perform all the tasks in Vivado. The SDK operations must be done in the SDK GUI. You might need to modify the Tcl script to match the project path and project name on your machine.

Please Read: Important Legal Notices

The information disclosed to you hereunder (the “Materials”) is provided solely for the selection and use of Xilinx products. To the maximum extent permitted by applicable law: (1) Materials are made available “AS IS” and with all faults, Xilinx hereby DISCLAIMS ALL WARRANTIES AND CONDITIONS, EXPRESS, IMPLIED, OR STATUTORY, INCLUDING BUT NOT LIMITED TO WARRANTIES OF MERCHANTABILITY, NON-INFRINGEMENT, OR FITNESS FOR ANY PARTICULAR PURPOSE; and (2) Xilinx shall not be liable (whether in contract or tort, including negligence, or under any other theory of liability) for any loss or damage of any kind or nature related to, arising under, or in connection with, the Materials (including your use of the Materials), including for any direct, indirect, special, incidental, or consequential loss or damage (including loss of data, profits, goodwill, or any type of loss or damage suffered as a result of any action brought by a third party) even if such damage or loss was reasonably foreseeable or Xilinx had been advised of the possibility of the same. Xilinx assumes no obligation to correct any errors contained in the Materials or to notify you of updates to the Materials or to product specifications. You may not reproduce, modify, distribute, or publicly display the Materials without prior written consent. Certain products are subject to the terms and conditions of Xilinx’s limited warranty, please refer to Xilinx’s Terms of Sale which can be viewed at <https://www.xilinx.com/legal.htm#tos>; IP cores may be subject to warranty and support terms contained in a license issued to you by Xilinx. Xilinx products are not designed or intended to be fail-safe or for use in any application requiring fail-safe performance; you assume sole risk and liability for use of Xilinx products in such critical applications, please refer to Xilinx’s Terms of Sale which can be viewed at <https://www.xilinx.com/legal.htm#tos>.

AUTOMOTIVE APPLICATIONS DISCLAIMER

AUTOMOTIVE PRODUCTS (IDENTIFIED AS “XA” IN THE PART NUMBER) ARE NOT WARRANTED FOR USE IN THE DEPLOYMENT OF AIRBAGS OR FOR USE IN APPLICATIONS THAT AFFECT CONTROL OF A VEHICLE (“SAFETY APPLICATION”) UNLESS THERE IS A SAFETY CONCEPT OR REDUNDANCY FEATURE CONSISTENT WITH THE ISO 26262 AUTOMOTIVE SAFETY STANDARD (“SAFETY DESIGN”). CUSTOMER SHALL, PRIOR TO USING OR DISTRIBUTING ANY SYSTEMS THAT INCORPORATE PRODUCTS, THOROUGHLY TEST SUCH SYSTEMS FOR SAFETY PURPOSES. USE OF PRODUCTS IN A SAFETY APPLICATION WITHOUT A SAFETY DESIGN IS FULLY AT THE RISK OF CUSTOMER, SUBJECT ONLY TO APPLICABLE LAWS AND REGULATIONS GOVERNING LIMITATIONS ON PRODUCT LIABILITY.

© Copyright 2013 – 2017 Xilinx, Inc. Xilinx, the Xilinx logo, Artix, ISE, Kintex, Spartan, Virtex, Zynq, and other designated brands included herein are trademarks of Xilinx in the United States and other countries. All other trademarks are the property of their respective owners.