

ARMv8-A A64 ISA Overview

Agenda

- **Introduction**

Registers

Loads and stores

Data processing and control flow

Scalar floating-point and SIMD

Introduction

- **This is a general introduction to the A64 instruction set**
 - But does not cover all available instructions
 - Does not detail all forms, options, and restrictions for each instruction
- **For more information, see the following on infocenter.arm.com:**
 - ARMv8-A Architecture Reference Manual. Document number: **DDI 0487**
 - **ARM®** Compiler 6 armasm Reference Guide. Document number: **DUI 0802**
 - Has an A-Z listing of all available instructions and can be easier to digest than the ARMv8-A Architecture Reference Manual
 - ARM Architecture Procedure Call Standard for 64-bit (AAPCS64). Document number **IHI 0055B**
 - How registers are used by compilers, how arguments are passed, etc.
- **For presentations on 64-bit Android on ARM see:**
 - [LCU14-504: Taming ARMv8 NEON: from theory to benchmark results – YouTube](#): Using **NEON™** in native code
 - [HKG15-300: Art's Quick Compiler: An unofficial overview – YouTube](#): A64 support in the Android Java runtime
 - [LCU14-100: Dalvik is Dead, Long Live Dalvik! OR Tuning ART – YouTube](#): Porting Android to 64-bit ARM
 - [More Presentations on Porting to 64-bit](#)

Key differences from A32

- **31 general purpose registers, all 32-bits (w_n) or 64-bits (x_n)**
 - Program Counter and Stack Pointer are no longer general purpose and therefore cannot be used by most instructions
- **Load/store addressing modes are now consistent across sizes and type**
- **No Load Multiple (`LDM`), Store Multiple (`STM`), `PUSH`, or `POP` instructions**
 - Construct these operations using the new Load Pair (`LDP`) / Store Pair (`STP`) instructions
- **Unaligned accesses are supported by almost all instructions (except for exclusive accesses)**
- **No conditionally executed instructions or `IT` instruction (except for conditional branches)**
 - Some conditional instructions that are **always** executed such as Conditional Select (`CSEL`)
- **Different immediate ranges (no longer 8-bit rotated)**
- **Saturating and SIMD instructions can only use the scalar floating-point / SIMD register bank**
- **No coprocessor instructions**
 - Functionality moved to system registers that are read by `MRS` and set by `MSR`

Instruction sets in ARMv8

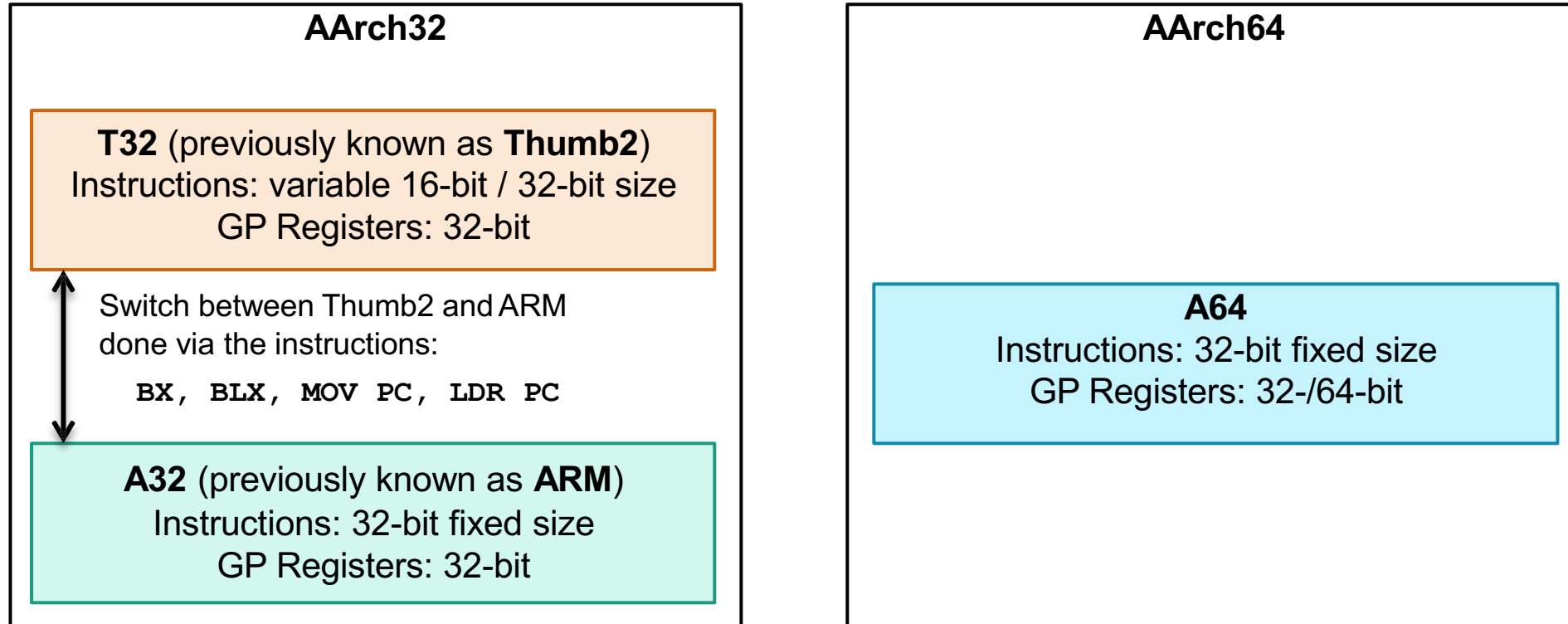

- **An application may mix A32 and T32 code, but not 32-bit and 64-bit code**
- AArch64 offers more general purpose (GP) registers than AArch32: 31 rather than 15
- All GP registers can store up to 64 bits: one `int64_t` integer requires 1 register rather than 2.
- Single process can use more than 4 GB of RAM: 64-bit virtual address space.

Agenda

Introduction

- **Registers**

Loads and stores

Data processing and control flow

Scalar floating-point and SIMD

Cryptographic instructions

Special dedicated registers

2 dedicated registers:

- **sp**, the stack pointer register: holds pointer to bottom of the stack
 - preferred register to access the stack
 - must be 16-bytes aligned

```
STR    W0, [SP, #4]    ; Stores W0 into the stack at address SP + 4.  
ADD    SP, SP, #8    ; WARNING: SP is now "unusable": it is not aligned anymore!  
STR    X0, [SP]      ; ERROR: cannot use unaligned SP!
```

- **zr**: the zero register
 - when used as source register it always returns the integer value zero.

```
MOV    W0, #0          ; W0 = 0  
MOV    W0, WZR         ; W0 = 0, same effect as previous instruction
```

- when used as a destination register it discards the value

```
SUBS   WZR, W10, W11   ; Does W10 - W11, set the flags and discard the result  
CMP    W10, W11        ; Compare two numbers: CMP is an alias for the SUBS above
```

Two ways of writing the same instruction

Scalar FP and SIMD registers

- **Separate set of 32 registers, each 128-bit wide**
 - Architecturally named $v0 - v31$
 - Used by scalar floating-point and SIMD instructions
- **The instruction syntax uses qualified register names**
 - B_n for byte, H_n for half-word, S_n for single-word, D_n for double-word, Q_n for quad-word

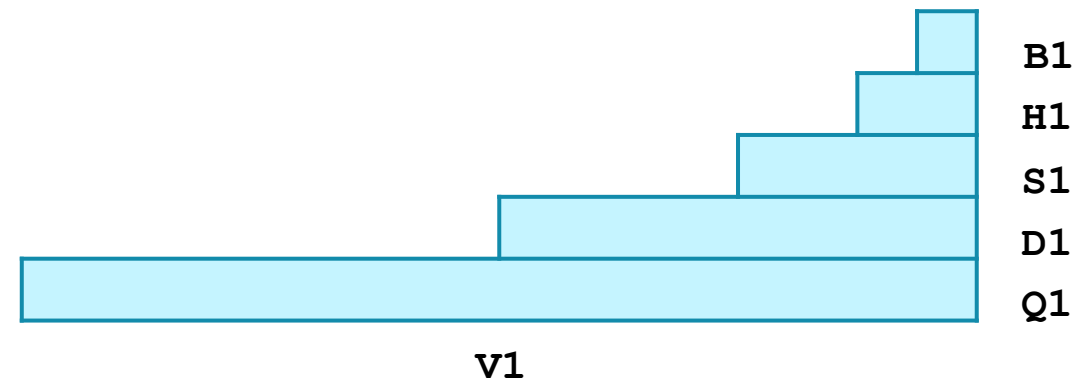
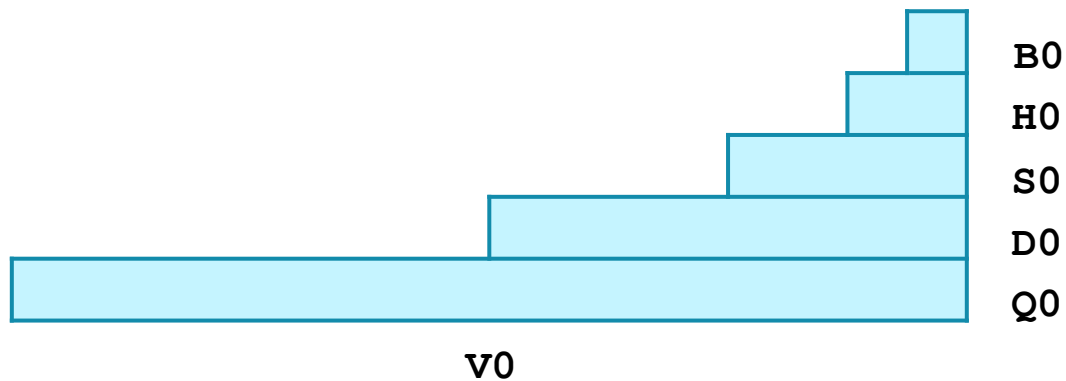

System registers

- **System registers define the processor context**
 - Controls the behavior of the processor
- **System registers are suffixed with “_ELx”, for example SCTLR_EL1**
 - Suffix defines the lowest exception level that can access that system register
- **MRS**
 - Read a system register
- **MSR**
 - Set a system register

```
MRS    X0, SCTLR_EL1      ; X0 = SCTLR_EL1
MSR    SCTLR_EL1, X0      ; SCTLR_EL1 = X0
```

Agenda

Introduction

Registers

- **Loads and stores**

Data processing and control flow

Scalar floating-point and SIMD

Cryptographic instructions

Register load/store

- **LDR**
 - Load data from an address into a register

- **STR**
 - Store data from a register to an address

```
LDR    X0, <addr>           ; Load from <addr> into X0
```

```
STR    X0, <addr>           ; Store contents of X0 to <addr>
```

- **By default, the size of the load/store is determined by the source/destination register name**
 - X_n will load/store 64 bits, W_n will load/store 32 bits
 - Instruction can be suffixed to force a smaller load/store size
 - 'B' for byte, 'H' for half-word, 'W' for word
 - Result will be zero-extended by default, combine with the 'S' suffix for sign-extension

```
LDRSB  X0, <addr>           ; Load byte from <addr> into X0 and sign-extend
```

```
STRH   W1, <addr>           ; Store half-word from W1 to <addr>
```

Example: Byte loads

Hex 8A is decimal **-118** or **138**
depending on whether it is
considered **signed** or **unsigned**

Sign-extended 8-bit load to a w_n register:

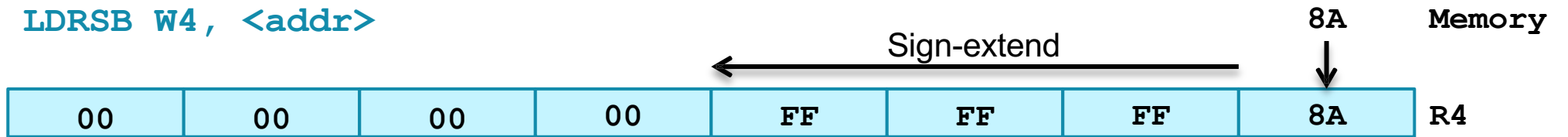

Sign-extended 8-bit load to an x_n register:



Zero-extended 8-bit load to a w_n register:

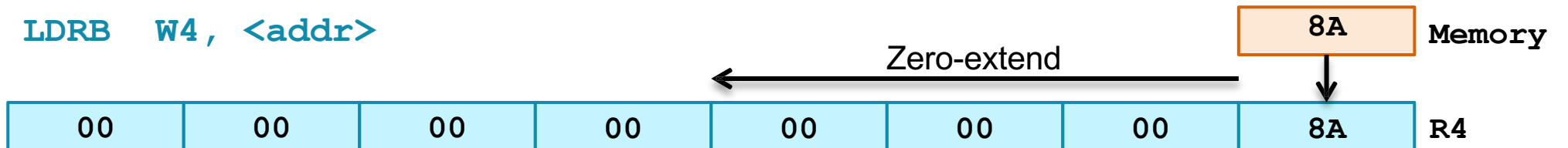

Specifying the load/store address

- Address to load/store from is a 64-bit base register plus an optional offset

```
LDR    X0, [X1]           ; Load from address held in X1
STR    X0, [X1]           ; Store to address held in X1
```

- Offset can be an immediate or a register

```
LDR    X0, [X1, #8]       ; Load from address [X1 + 8 bytes]
LDR    X0, [X1, #-8]      ; Load with negative offset
LDR    X0, [X1, X2]       ; Load from address [X1 + X2]
```

- A w_n register offset needs to be extended to 64 bits

```
LDR    X0, [X1, W2, SXTW] ; Sign-extend offset in W2
LDR    X0, [X1, W2, UXTW] ; Zero-extend offset in W2
```

- Both x_n and w_n register offsets can include an optional left-shift

```
LDR    X0, [X1, W2, UXTW #2] ; Zero-extend offset in W2 & left-shift by 2
LDR    X0, [X1, X2, LSL #2]   ; Left-shift offset in X2 by 2
```

Addressing modes

Simple: X1 is not changed

```
LDR W0, [X1]
```

Offset: X1 is not changed

```
LDR W0, [X1, #4]
```

Pre-indexed: X1 changed before load

```
LDR W0, [X1, #4]!
```



```
ADD X1, X1, #4  
LDR W0, [X1]
```

Post-indexed: X1 changed after load

```
LDR W0, [X1], #4
```



```
LDR W0, [X1]  
ADD X1, X1, #4
```

```
/* Analogous C code */  
int *intptr = ...;    // X1  
int out;              // W0
```

```
out = *intptr;
```

```
out = intptr[1];
```

```
out = *(++intptr);
```

```
out = *(intptr++);
```

Floating-point loads and stores

- **Load and store instructions can also target scalar FP / SIMD registers**
- **Size of load/store is determined by qualified name of target register**
 - **B_n** for byte, **H_n** for half-word, **S_n** for single-word, **D_n** for double-word, **Q_n** for quad-word
 - No size or sign specifier on instruction
- **Address is still specified by an x_n register base plus an optional offset**
 - Same range and options as scalar integer loads

```
LDR    D1, [X0]           ; Load 64-bits from [X0] into D1
STR    Q0, [X0, X1]       ; Store 128-bits from Q0 to [X0 + X1]
```

Register pair load/store

- **New Load Pair and Store Pair instructions**

- Support both integer and scalar FP / SIMD registers
- Both source/destination registers must be the same width

```
LDP    W3, W7, [X0]           ; [X0] => W3, [X0 + 4 bytes] => W7
STP    Q0, Q1, [X4]          ; Q0 => [X4], Q1 => [X4 + 16 bytes]
```

- **No Load Multiple, Store Multiple, or PUSH / POP instructions in AArch64**

- Construct these operations using `STP` and `LDP` instructions

```
STP    X0, X1, [SP, #-16]!    ; Push X0 and X1 onto the stack
LDP    X0, X1, [SP], #16     ; Pop X0 and X1 from the stack
```

Using the PC

- **There are variants of LDR to load PC relative data**

- Use a label operand rather than a 64-bit base address register
- Linker generates a PC relative load from the address of the label in the executable image

```
LDR    X0, label           ; Load value at <label>
```

- **Assemblers may support a “Load (immediate)” pseudo-instruction**

- Creates a PC relative load, and a literal pool containing the value to be loaded

```
LDR    X0, =imm           ; Load from literal containing imm
```

- **Obtaining the address of a label**

- PC relative loads and ADR are limited in range to $\pm 1\text{MB}$, whereas ADRP has range $\pm 4\text{GB}$

```
LDR    X0, =label        ; Load address of label from literal pool
ADR    X0, label         ; Calculate address of label (PC relative)
ADR    X0, .             ; Get current PC (address of ADR instruction)
ADRP   X0, label         ; Calculate address of 4KB page containing label
```

Agenda

Introduction

Registers

Loads and stores

- **Data processing and control flow**

Scalar floating-point and SIMD

Cryptographic instructions

Data processing

- **Values in registers can be processed using many different instructions**
 - Arithmetic, logic, data moves, bit field manipulations, shifts, conditional comparisons, and more
 - These instructions always operate between registers, or between a register and an immediate

Example bit manipulation:

```
; Clear bit 4, set bit 7 at X1
LDR    X0, [X1]
AND    X0, X0, #~(1 << 4)
ORR    X0, X0, #(1 << 7)
STR    X0, [X1]
```

Example countdown loop:

```
; add W3 to all elements of an
; array of loop_count ints in X2
MOV    X0, #<loop_count>
loop:
LDR    W1, [X2]
ADD    W1, W1, W3
STR    W1, [X2], #4
SUB    X0, X0, #1
CBNZ  X0, loop
```

Shifts and rotates

- **Standalone instructions for shifts and rotates**

- Source register may be an **x_n** or **w_n** register
- Also used for flexible second operands, such as to shift an **LDR / STR x_n** register offset

- **Shift amount may be an immediate or a register**

- Immediate shifts up to (register_size – 1)
- Register values taken modulo 32-bit or 64-bit

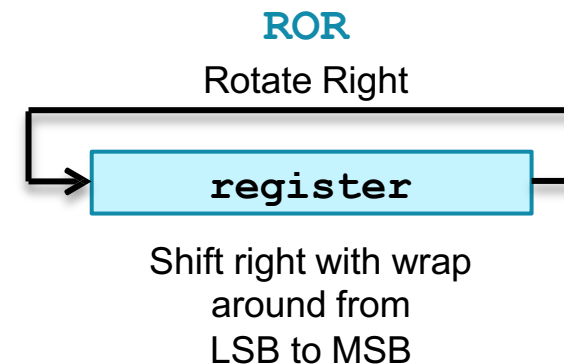
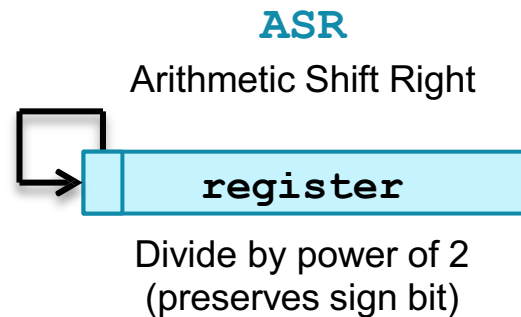
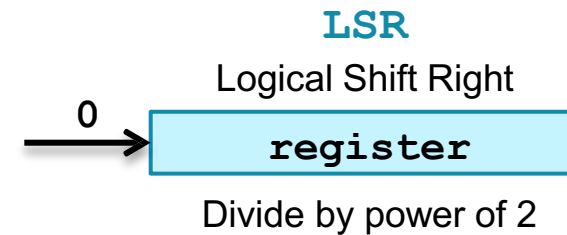
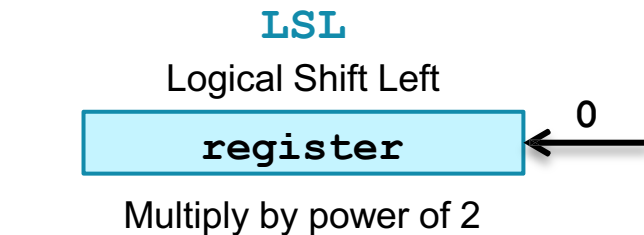

Bit manipulation (1)

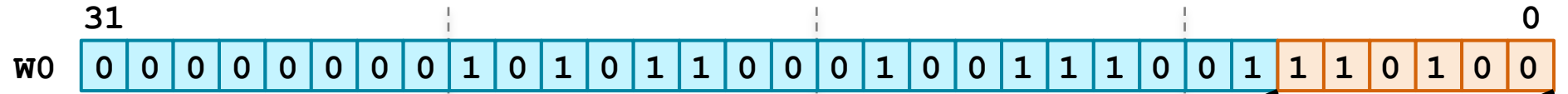

`BFI W0, W0, #9, #6 ; Bit Field Insert`

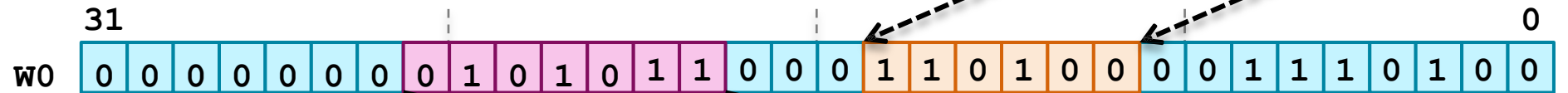

`UBFX W1, W0, #18, #7 ; Bit Field Extract`

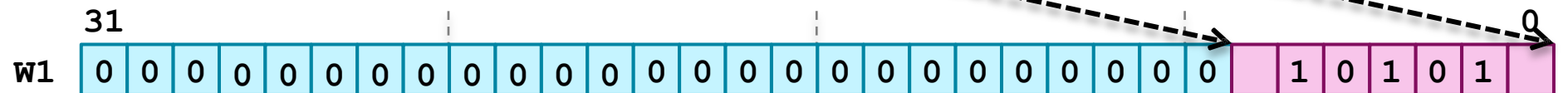

`BFI W1, WZR, #3, #4 ; Bit Field Clear`

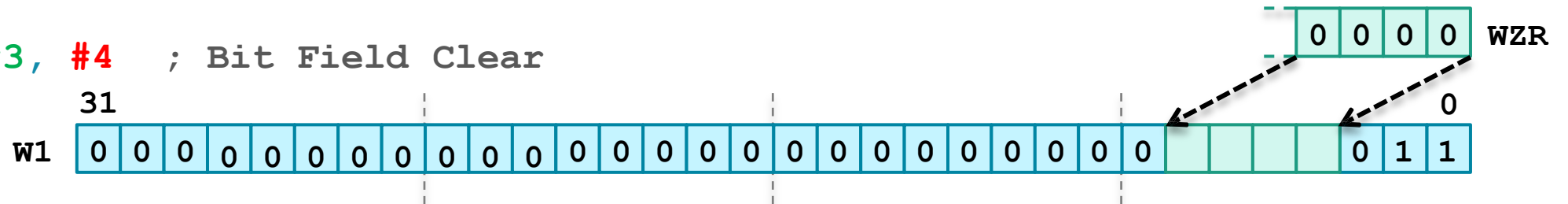

These are just some examples, there are many more bit manipulation instructions

Bit manipulation (2)

- Count leading sign-bits / zeros
 - **CLS / CLZ**
- Reverse bit order of a register (MSB \leftrightarrow LSB)
 - **RBIT**
- Reverse byte order of a register
 - **REV** reverse the order of bytes
 - **REV16** variant reverses the order of each half-word in a register
 - **REV32** variant reverses the order of each single-word in a register
 - Source register for **REV32** must be an **xn** register

Extension

- **SXTB / SXTH / SXTW**
 - Sign-extend byte / half-word / single-word
- **UXTB / UXTH / UXTW**
 - Zero-extend byte / half-word / single-word
- **Destination register may be an x_n or w_n register**
 - w_n destination extends source to 32-bits, x_n destination extends source to 64-bits
 - Source register must always be a w_n register

```
SXTB    X3, W2           ; Sign-extend low byte of W2 to 64-bits
UXTH    W4, W5           ; Zero-extend low half-word of W5 to 32-bits
SXTW    X6, W7           ; Sign-extend word in W7 to 64-bits
```

Multiplication and division

- Regular 32-bit and 64-bit multiplication:
 - **MUL** *Rd, Rn, Rm* □ $Rd = Rn * Rm$ (alias of **MADD**: $Ra = ZR$)
 - **MADD** *Rd, Rn, Rm, Ra* □ $Rd = Ra + Rn * Rm$
 - **MSUB** *Rd, Rn, Rm, Ra* □ $Rd = Ra - Rn * Rm$
 - **MNEG** *Rd, Rn, Rm* □ $Rd = -Rn * Rm$ (alias of **MSUB**: $Ra = ZR$)
- Long result multiplication: 32-bit source registers, 64-bit destination register.
 - Signed variants: **SMULL, SMADDL, SMSUBL, SMNEGL**
 - Unsigned variants: **UMULL, UMADDL, UMSUBL, UMNEGL**
 - Upper 64 bits in 128-bit multiplication result: **UMULH, SMULH**
- Signed and unsigned 32-bit and 64-bit division
 - **SDIV / UDIV** *Rd, Rm, Rn* □ $Rd = Rn / Rm$
 - Division by 0 returns 0 (with no exception)
 - **MAXNEG** integer divided by -1 overflows (returns **MAXNEG**)

Branches

- **B** <offset>
 - PC relative branch ± 128 MB
 - Conditional version **B.cond** (covered later) has ± 1 MB range
- **BL** <offset>
 - Similar to **B** (branch range ± 128 MB) but also stores return address in **LR** (**x30**), hinting that this is a function call
 - No conditional version
- **BR** **Xm**
 - Absolute branch to address in **Xm**
- **BLR** **Xm**
 - Similar to **BR**, but also stores return address in **LR** (**x30**), hinting that this is a function call
- **RET** **Xm** or simply **RET**
 - Similar to **BR**, but also hints that this is a function return
 - Use **LR** (**x30**) if register is omitted, but can use other register

Conditional execution

- **A64 does not allow instructions to be conditionally executed**
 - Except for branch instructions
 - Unlike A32, which allows for most instructions to include a condition code, for example `ADDEQ R0, R1, R2`
 - Unlike T32, which supports the `IT` (If Then) instruction
- **A64 has conditional operations**
 - These instructions are always executed, but their result depends on the ALU flags
- **Some data processing instructions will set the ALU flags after execution**
 - Mnemonics appended with 's', for example `SUBS`
 - Some encodings have preferred syntax for disassembly to aid in clarity

```
SUBS    X0, X1, X2           ; X0 = (X1 - X2), and set ALU flags
TST     X0, #(1 << 20)      ; Alias of ANDS XZR, X0, #(1 << 20)
CMP     X0, #5               ; Alias of SUBS XZR, X0, #5
```

Setting the ALU flags

- The ALU flags are part of PSTATE
 - NZCV → Negative, Zero, Carry, Overflow

```
MOV    X0, #1           ; NZCV
SUBS   X1, X0, X0       ; 0100

MOV    W0, #0xFFFFFFFF ; NZCV
MOV    W1, #1

ADDS   W2, W0, W1       ; 0110

MOV    W0, #0           ; NZCV
MOV    W1, #1

SUBS   W2, W0, W1       ; 1000
```

Using the ALU flags

- **Condition codes change the behaviour of some instructions based on the ALU flags**
 - Suffixed to conditional branches, for example `B.EQ label`
 - Passed as an operand to conditional operations, for example `CSINC W0, EQ`
- **Some of the available condition codes are shown below**
 - See appendix for complete list

Condition Code	Description	ALU Flags
EQ	Equal	Z == 1
NE	Not Equal	Z == 0
CS / HS	Unsigned Higher or Same	C == 1
CC / LO	Unsigned Lower	C == 0
MI	Minus	N == 1

Conditional branches

- **B.cond**

- Branch to label if condition code evaluates to true

```
CMP    X0, #5
B.EQ   label           ; Branch to label if (X0 == #5)
```

- **CBZ / CBNZ**

- Branch to label if operand register is equal to zero (**CBZ**) or not equal to zero (**CBNZ**)

```
CBZ    X0, label       ; Branch to label if (X0 == #0)
CBNZ   W0, label       ; Branch to label if (W0 != #0)
```

- **TBZ / TBNZ**

- Branch to a label if a specific bit in the operand register is set (**TBNZ**) or cleared (**TBZ**)

```
TBZ    W0, #20, label  ; Branch to label if (W0[20] == #0b0)
TBNZ   X0, #50, label  ; Branch to label if (X0[50] == #0b1)
```

Conditional operations

- **CSEL**

- Select between two registers based on a condition

```
CSEL X7, X2, X0, EQ ; if (cond == true) X7 = X2, else X7 = X0
```

- **CSINC / CSINV / CSNEG**

- Variants of **CSEL** that cause the second source register to be processed in several ways
- **CSINC** increments, **CSINV** inverts, **CSNEG** negates

```
CSINC X7, X2, X0, EQ ; if (cond == true) X7 = X2, else X7 = (X0 + #1)
```

- Aliases of these instructions for setting a register to a constant:

```
CSET W2, HS ; if (cond == true) W2 = 1, else W2 = 0
```

```
CSETM X1, LO ; if (cond == true) X1 = -1, else X1 = 0
```

Example: Condition execution

C Source Code:

```
if (a == 0)
{
    y = y + 1;
}
else
{
    y = y - 1;
}
```

A32 Conditional Execution:

```
CMP    R0, #0
ADDEQ  R1, R1, #1
SUBNE  R1, R1, #1
```

A64 Conditional Branching:

```
        CMP    W0, #0
        B.NE   else
        ADD    W1, W1, #1
        B      end
else:
        SUB    W1, W1, #1
end:
```

A64 Conditional Operations:

```
        CMP    W0, #0
        SUB    W2, W1, #1
        CSINC  W1, W2, W1, NE
```

```
CSINC W0, W1, W2, cond
W0 = (cond) ? W1 : W2 + 1
```

Agenda

Introduction

Registers

Loads and stores

Data processing and control flow

- **Scalar floating-point and SIMD**

Cryptographic instructions

Floating-point operations

- **Scalar floating-point equivalents exist for most general purpose data processing instructions**
 - **Prefixed with 'F':** FABS, FNEG, FSQRT, FADD, FSUB, FDIV, FMUL, FMADD, FMSUB, FCMP, FCCMP, FCSEL, ...

```
FMADD  D3, D11, D15, D0    ; D3 = ((D11 * D15) + D0) (fused)
FCMP   S7, S9              ; Set NZCV flags based on comparison
FCSEL  D5, D4, D3, EQ      ; if (cond == true) D5 = D4, else D5 = D3
```

- **SCVTF / UCVTF**
 - Convert signed / unsigned scalar integer to floating-point
 - Rounding mode specified by **FPCR** register
- **FCVT...S / FCVT...U**
 - Convert scalar floating-point to signed / unsigned scalar integer
 - Rounding mode specified by additional **CVT** suffix
- **Can also use FMOV to move data without conversion**

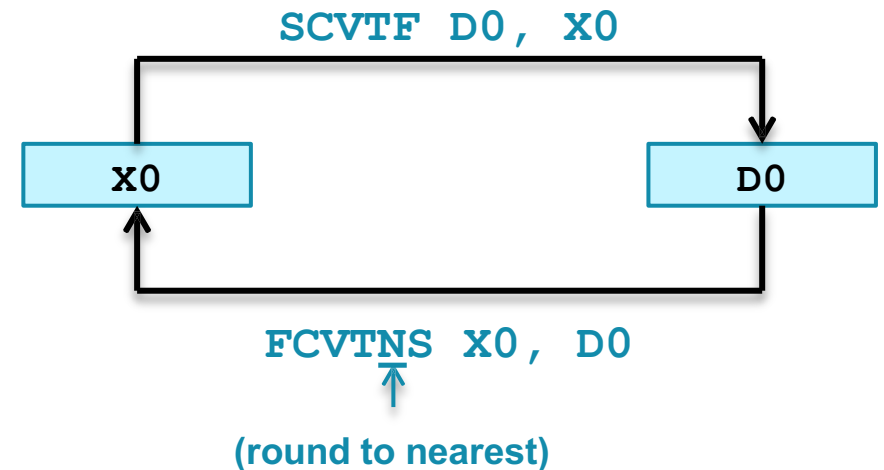

SIMD operations

- Operand registers are treated as being vectors of individual elements
- Operations are performed simultaneously on a number of “lanes”
 - In this example each lane contains a pair of 32-bit elements, one from each of the operand 128-bit vector registers

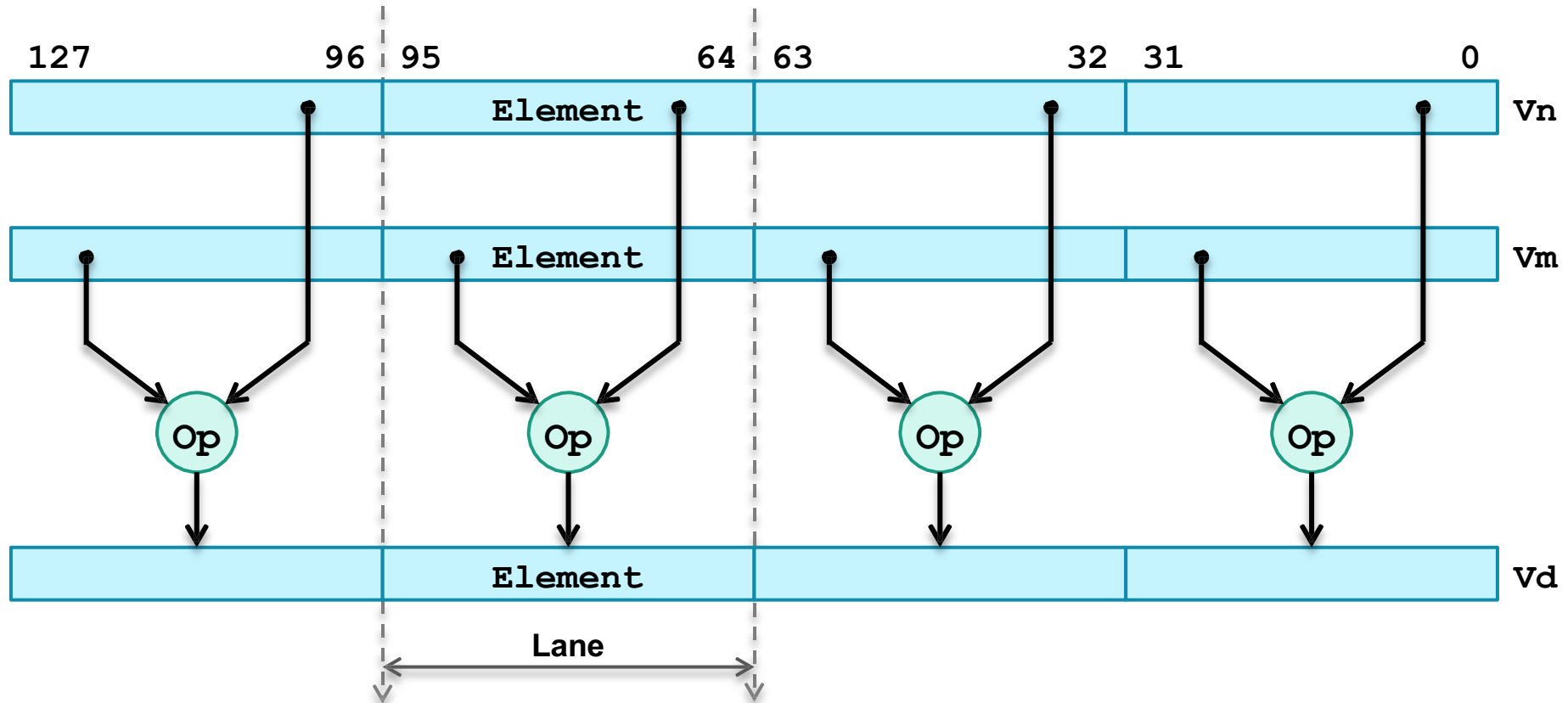

Vectors

- **When accessing a SIMD vector, the v_n register name is used, with an extension to indicate the number and size of elements in the vector**
- $V_n.xy$
 - n is the register number, x is the number of elements, y is the size of the elements encoded as a letter

```
FADD    V0.2D, V5.2D, V6.2D        ; 2x double-precision floats
```

- **Total vector length must be either 128-bits or 64-bits**
 - If 64-bits are written, $v_n[127:64]$ are automatically cleared to 0

```
ADD     V0.8H, V3.8H, V4.8H        ; 8x 16-bit integers
```

```
ADD     V0.8B, V3.8B, V4.8B        ; 8x 8-bit integers, clear top of V0
```

- **Some instructions refer to a single element of a vector**
 - Example: $v3.B[3]$ – Byte in $v3[23:16]$
 - Rest of register is unaffected when an element is written

```
FMUL    V0.4S, V2.4S, V3.S[2]      ; Multiply each element of V2 by V3.S[2]
```

Agenda

Introduction

Registers

Loads and stores

Data processing and control flow

Scalar floating-point and SIMD

Cryptographic instructions

AArch64 cryptographic instructions

Instruction		Description
PMULL	Vd.1Q, Vn.1D, Vm.1D	Polynomial Multiply Long (Vector)
PMULL2	Vd.1Q, Vn.2D, Vm.2D	Polynomial Multiply Long (Vector, Part 2)
AESE	Vd.16B, Vn.16B	AES Single Round Encrypt
AESD	Vd.16B, Vn.16B	AES Single Round Decrypt
AESMC	Vd.16B, Vn.16B	AES Mix Columns
AESIMC	Vd.16B, Vn.16B	AES Inverse Mix Columns
SHA256H	Qd, Qn, Vm.4S	SHA256 Hash Update Accelerator
SHA256H2	Qd, Qn, Vm.4S	SHA256 Hash Update Accelerator (Part 2)
SHA256SU0	Vd.4S, Vn.4S	SHA256 Schedule Update
SHA256SU1	Vd.4S, Vn.4S, Vm.4S	SHA256 Schedule Update (Part 2)
SHA1C	Qd, Sn, Vm.4S	SHA1 Hash Update Accelerator (Choose)
SHA1P	Qd, Sn, Vm.4S	SHA1 Hash Update Accelerator (Parity)
SHA1M	Qd, Sn, Vm.4S	SHA1 Hash Update Accelerator (Majority)
SHA1H	Sd, Sn	SHA1 Hash Update Accelerator (Rotate Left by 30)
SHA1SU0	Vd.4S, Vn.4S, Vm.4S	SHA1 Schedule Update Accelerator
SHA1SU1	Vd.1Q, Vn.1D, Vm.1D	SHA1 Schedule Update Accelerator (Part 2)

Appendix

AAPCS64: Role of integer registers

Register	Alternative name	Role
R0		Return value (for integers and pointers)
R0 ... R7		Arguments in function calls (for integers and pointers)
R8		Indirect result location register. Used in C++ for returning non-trivial objects (set by the caller).
R9 ... R15		Temporary registers (trashed across calls)
R16, R17	IP0, IP1	The intra-procedure-call temporary registers. The linker may use these in PLT code. Can be used as temporary registers between calls
R18		Platform register
R19 ... R28		Callee-saved registers: register preserved across calls
R29	FP	Frame pointer. Copy of SP before function stack allocation
R30	LR	Link register. BL and BLR instructions save return address in it
SP		Stack pointer

AAPCS64: Role of floating-point registers

Register	Role
v0	Return value (for floating-point values)
v0 ... v7	Arguments in function calls (for floating-point values)
v8 ... v15	Callee-saved registers. The bottom 64 bits of these registers are preserved across calls. Upper 64 bits must be saved by the caller if needed.
v16 ... v31	Temporary registers (trashed across calls)

Specifying register load size

Load Size	Extension	Xn	
8-bit	Zero	--	
	Sign	LDRSB	
16-bit	Zero	--	
	Sign	LDRSH	
32-bit	Zero	--	
	Sign	LDRSW	
64-bit	Zero	LDR	

- There is no encoding for a zero-extended load of less than 64-bits to an **Xn** register
 - Writing to a **Wn** register automatically clears bits [63:32], which accomplishes the same thing

Store Size	Xn	Wn
8-bit	--	STRB
16-bit	--	STRH
32-bit	--	STR
64-bit	STR	--

Condition codes

Condition Code	Description	Flags Tested
EQ	Equal	Z == 1
NE	Not Equal	Z == 0
CS / HS	Unsigned Higher or Same	C == 1
CC / LO	Unsigned Lower	C == 0
MI	Minus	N == 1
PL	Positive or Zero	N == 0
VS	Overflow	V == 1
VC	No Overflow	V == 0
HI	Unsigned Higher	C == 1 && Z == 0
LS	Unsigned Lower or Same	C == 0 && Z == 1
GE	Greater Than or Equal	N == V
LT	Less Than	N != V
GT	Greater Than	Z == 0 && N == V
LE	Less Than or Equal	Z == 1 N != V
AL	Always	--

NZCV → Negative, Zero, Carry, Overflow