

Jonathan W. Valvano

First: \_\_\_\_\_ Last: \_\_\_\_\_

October 7, 2015, 10:00am-10:50am. This is a closed book exam, with one 8.5 by 11 inch crib sheet. You have 50 minutes, so please allocate your time accordingly. *Please read the entire quiz before starting.*

(20) **Question 1.** Mark each of the following questions true or false. Put answers in the boxes

Part a) We are sampling the ADC using hardware averaging. In order to apply the **Central Limit Theorem** we assume the original data independent and identically distributed random variables.

Part b) Adding **const** in the following example causes **Size** to be allocated in ROM on a microcontroller.

```
void function1(const int Size){
```

Part c) Adding **static** in this example has the effect of changing the allocation of **Count** from the stack/registers to permanent RAM.

```
void function2(void){ static int Count=0;
```

Part d) In the **OpenWeatherMap.org** communication, the connection socket is used to pass data between the client and the server.

Part e) Adding capacitance to digital signals decreases slew rate causing slower transmission.

(5) **Question 2.** Consider the interaction between this ISR and this main program. You may assume Port B has been initialized as an 8-bit output and no other software accesses Port B. The desired behavior is to toggle four bits whenever the ISR occurs, and to toggle a different four bits each time through the loop.

```
void SysTickHandler(void){
    GPIO_PORTB_DATA_R ^= 0x55;
    // other stuff
}
```

```
void main(void){
    Init();
    while(1){
        GPIO_PORTB_DATA_R ^= 0xAA;
        // other stuff
    }
}
```

Do these accesses to Port B create a critical section? Answer yes or no.

(5) **Question 3.** You wish to connect a device to a GPIO output of the TM4C123. These are the parameters of the I/O device:

$$\begin{aligned} I_{IL} &= 100\mu\text{A}, & I_{IH} &= 100\mu\text{A}, \\ V_{IL} &= 0.5\text{V}, & V_{IH} &= 2.2\text{ V} \end{aligned}$$

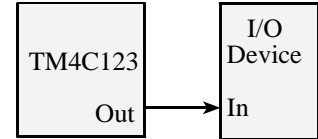

Can you directly connect a TM4C123 output to this device? Select Yes or No:

If yes, prove it. If no, show at least one parameter/equation not satisfied.

(5) **Question 4.** Consider an ideal inductor, with inductance  $L$ . Let  $V$  be the voltage across the inductor, and let  $I$  be the current through the inductor. Give an equation that relates  $L$ ,  $I$ , and  $V$ .

(5) **Question 5.** We need to store values from 0 to +10 m, but must limit memory to 8 bits. Choose the best **decimal fixed-point** format assuming we are using 8-bit precision. I.e., what resolution should we use, including units?

(15) **Question 6)** You are asked to configure all 8 bits of Port B for priority 2 rising edge interrupts. You must be friendly. Put your answers in the boxes.

```
SYSCTL_RCGCGPIO_R |= 0x02;
delay = SYSCTL_RCGCGPIO_R;
GPIO_PORTB_PCTL_R = 0x00000000;
GPIO_PORTB_DIR_R = 0x00;
GPIO_PORTB_DEN_R = 0xFF;
```

```
GPIO_PORTB_IS_R =  ;
```

```
GPIO_PORTB_IBE_R =  ;
```

```
GPIO_PORTB_IEV_R =  ;
```

```
GPIO_PORTB_IM_R =  ;
```

```
NVIC_PRI0_R = (NVIC_PRI0_R &  ) |  ;
```

```
NVIC_EN0_R =  ;
```

(5) **Question 7.** Consider the following user application that should create a squarewave on PBO

```
int main(void){
    Init(); // initialize Port B
    while(1){
        GPIO_PORTB_DATA_R &= ~0x01; // make it low
        GPIO_PORTB_DATA_R |= 0x01; // make it high
    }
}
```

Describe a debugging technique you could use to determine the frequency and duty cycle of this output. Make it as noninvasive as possible.

**(30) Question 8.** The goal is to create a digital output wave on PB0 with a fixed period of 100ms and a variable duty cycle from 1 to 99%. The **Duty** is a shared global. E.g., if **Duty** is 25 then the wave should have a 25% duty cycle (high for 25 ms, and low for 75 ms). The main program, which you do not write, sets the global and your ISR reads it. You must use SysTick periodic interrupts for this solution, where once the initialization is called, the main program is free to run other unrelated operations. You cannot use any timer or PWM features of the TM4C123. Assume the bus clock is 16 MHz.

```
uint8_t Duty; // 1 to 99
```

```
#define PB0 (*((volatile uint32_t *)0x40005004))
```

**Part a)** Show the SysTick initialization function. Assume PB0 is already initialized as an output. Assume this is the only interrupt, so you can ignore priority. Do not include a main program, but do set I=0.

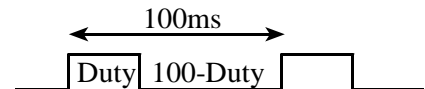

**Part b)** Show the SysTick ISR

(10) **Question 9.** Interface this 3-V 60-mA LED to PB0 using a PN2222A. Assume  $T=25^{\circ}\text{C}$ .

(2) Part a) Estimate  $h_{FE}$  for the conditions in this problem.

(3) Part b) Using  $h_{FE}$  as a variable, show the equation needed for minimum  $I_B$  required as a function of  $h_{FE}$ .

(2) Part c) What will be  $V_{CE}$  at saturation?

(3) Part d) Using  $V_{CE}$  as a variable, show the equation needed for  $R$  in ohms as a function of just one variable,  $V_{CE}$  in volts.

**Typical Pulsed Current Gain vs Collector Current**

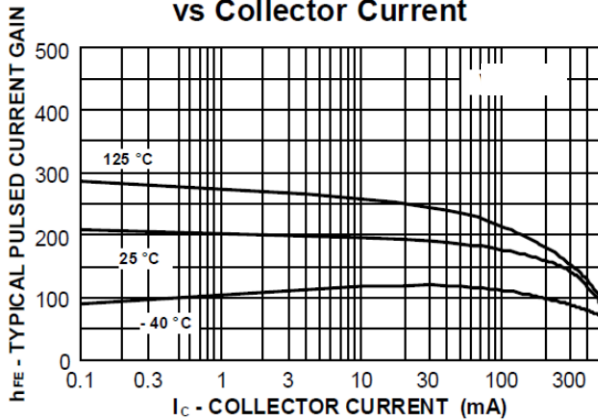

**Collector-Emitter Saturation Voltage vs Collector Current**

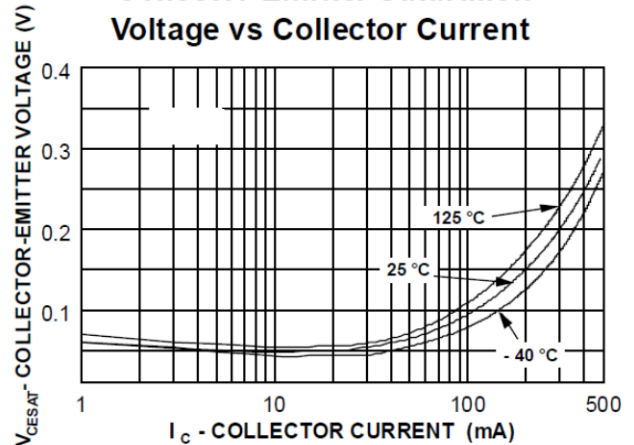

**Base-Emitter Saturation Voltage vs Collector Current**

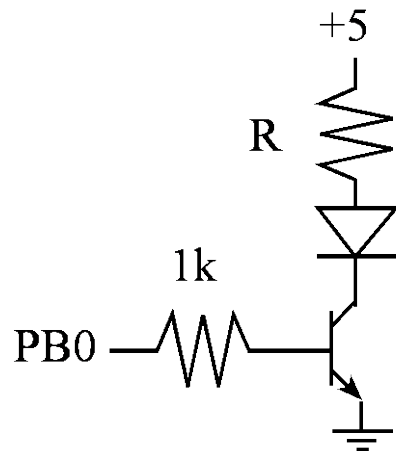
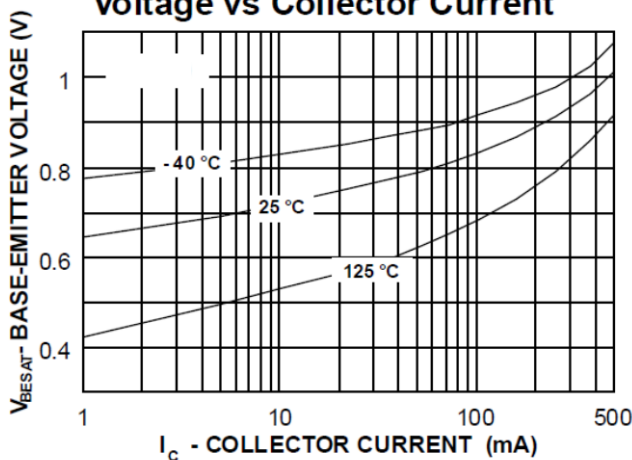

Parameters for the TM4C123 microcontroller (with 8mA mode selected)

$$I_{OL} = 8\text{mA}, \quad I_{OH} = 8\text{mA}, \quad I_{IL} = 2\mu\text{A}, \quad I_{IH} = 2\mu\text{A},$$

$$V_{OL} = 0.4\text{V}, \quad V_{OH} = 2.4\text{V}, \quad V_{IL} = 1.3\text{V}, \quad V_{IH} = 2.0\text{V}$$

7	6	5	4	3	2	1	0	Name
DATA	DATA	DATA	DATA	DATA	DATA	DATA	DATA	GPIO_PORTB_DATA_R
DIR	DIR	DIR	DIR	DIR	DIR	DIR	DIR	GPIO_PORTB_DIR_R
IS	IS	IS	IS	IS	IS	IS	IS	GPIO_PORTB_IS_R
IBE	IBE	IBE	IBE	IBE	IBE	IBE	IBE	GPIO_PORTB_IBE_R
IEV	IEV	IEV	IEV	IEV	IEV	IEV	IEV	GPIO_PORTB_IEV_R
IME	IME	IME	IME	IME	IME	IME	IME	GPIO_PORTB_IM_R
RIS	RIS	RIS	RIS	RIS	RIS	RIS	RIS	GPIO_PORTB_RIS_R
MIS	MIS	MIS	MIS	MIS	MIS	MIS	MIS	GPIO_PORTB_MIS_R
ICR	ICR	ICR	ICR	ICR	ICR	ICR	ICR	GPIO_PORTB_ICR_R
SEL	SEL	SEL	SEL	SEL	SEL	SEL	SEL	GPIO_PORTB_AFSEL_R
DRV2	DRV2	DRV2	DRV2	DRV2	DRV2	DRV2	DRV2	GPIO_PORTB_DR2R_R
DRV4	DRV4	DRV4	DRV4	DRV4	DRV4	DRV4	DRV4	GPIO_PORTB_DR4R_R
DRV8	DRV8	DRV8	DRV8	DRV8	DRV8	DRV8	DRV8	GPIO_PORTB_DR8R_R
ODE	ODE	ODE	ODE	ODE	ODE	ODE	ODE	GPIO_PORTB_ODR_R
PUE	PUE	PUE	PUE	PUE	PUE	PUE	PUE	GPIO_PORTB_PUR_R
PDE	PDE	PDE	PDE	PDE	PDE	PDE	PDE	GPIO_PORTB_PDR_R
SLR	SLR	SLR	SLR	SLR	SLR	SLR	SLR	GPIO_PORTB_SLR_R
DEN	DEN	DEN	DEN	DEN	DEN	DEN	DEN	GPIO_PORTB_DEN_R
CR	CR	CR	CR	CR	CR	CR	CR	GPIO_PORTB_CR_R
AMSEL	AMSEL	AMSEL	AMSEL	AMSEL	AMSEL	AMSEL	AMSEL	GPIO_PORTB_AMSEL_R

Address	31 – 29	23 – 21	15 – 13	7 – 5	Name
0xE000E400	GPIO Port D	GPIO Port C	GPIO Port B	GPIO Port A	NVIC_PRI0_R
0xE000E404	SSI0, Rx Tx	UART1, Rx Tx	UART0, Rx Tx	GPIO Port E	NVIC_PRI1_R
0xE000E408	PWM Gen 1	PWM Gen 0	PWM Fault	I2C0	NVIC_PRI2_R
0xE000E40C	ADC Seq 1	ADC Seq 0	Quad Encoder	PWM Gen 2	NVIC_PRI3_R
0xE000E410	Timer 0A	Watchdog	ADC Seq 3	ADC Seq 2	NVIC_PRI4_R
0xE000E414	Timer 2A	Timer 1B	Timer 1A	Timer 0B	NVIC_PRI5_R
0xE000E418	Comp 2	Comp 1	Comp 0	Timer 2B	NVIC_PRI6_R
0xE000ED20	SysTick	PendSV	--	Debug	NVIC_SYS_PRI3_R

Address	30	19	6	5	4	3	2	1	0	Name
0xE000E100	F	Timer0A	UART1	UART0	E	D	C	B	A	NVIC_EN0_R
0xE000E104								UART2		NVIC_EN1_R

Address	31-24	23-17	16	15-3	2	1	0	Name
\$E000E010	0	0	COUNT	0	CLK_SRC	INTEN	ENABLE	NVIC_ST_CTRL_R
\$E000E014	0	24-bit RELOAD value						NVIC_ST_RELOAD_R
\$E000E018	0	24-bit CURRENT value of SysTick counter						NVIC_ST_CURRENT_R